

AL125ULB

Access Control Power Supply/Charger Board

Altronix AL125ULB two (2) output switching Power Supply/Charger converts a low voltage AC input into two (2) individually PTC protected 12VDC or 24VDC outputs.

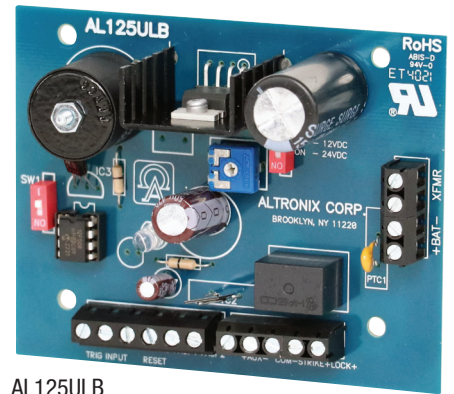

AL125ULB

Specifications

Input

Voltage 24VAC, 40VA from
UL Listed, Class 2 transformer

Outputs

Voltage 12VDC or 24VDC selectable
Current 1A supply current
Other PTC protected. Rated @ 2.5A
Short circuit and thermal overload protection
Filtered and regulated

Battery Charging

Type Sealed lead acid or gel type
Failover Upon AC loss, instantaneous
Batteries are sold separately

Supervision

Supervised Fire Alarm Disconnect
(Latching w/reset or Non-Latching)

Indicator (LED)

Unit Status Normal/No Output/Loss of AC/Triggered

Agency Listings

UL Recognized component
NFPA 101 (Life Safety)

Physical and Environmental

Dimensions (L x W x H)

Board: 3.8" x 3.0" x 1.5" (96.5mm x 76.2mm x 38.1mm)
Shipping: 8" x 6" x 5" (203.2mm x 152.4mm x 127mm)

Weight (approx.)

Product: 0.25 lb. (0.11 kg)
Shipping: 0.35 lb. (0.16 kg)

Temperature

Operating: 0°C to 49°C (32°F to 120°F)
Storage: -20°C to 70°C (-4°F to 158°F)

Relative Humidity

85% +/- 5%.

BTU/Hr (approx.)

6 or 12 BTU/Hr.

Lifetime Warranty

AL125ULB

Access Control Power Supply/Charger Board

Dimensions and Drawing

Board Dimensions (L x W x H approximate)

3.8" x 3.0" x 1.5" (96.5mm x 76.2mm x 38.1mm)

Mounting Holes' Tolerance: +/- 0.04 in. (1mm)

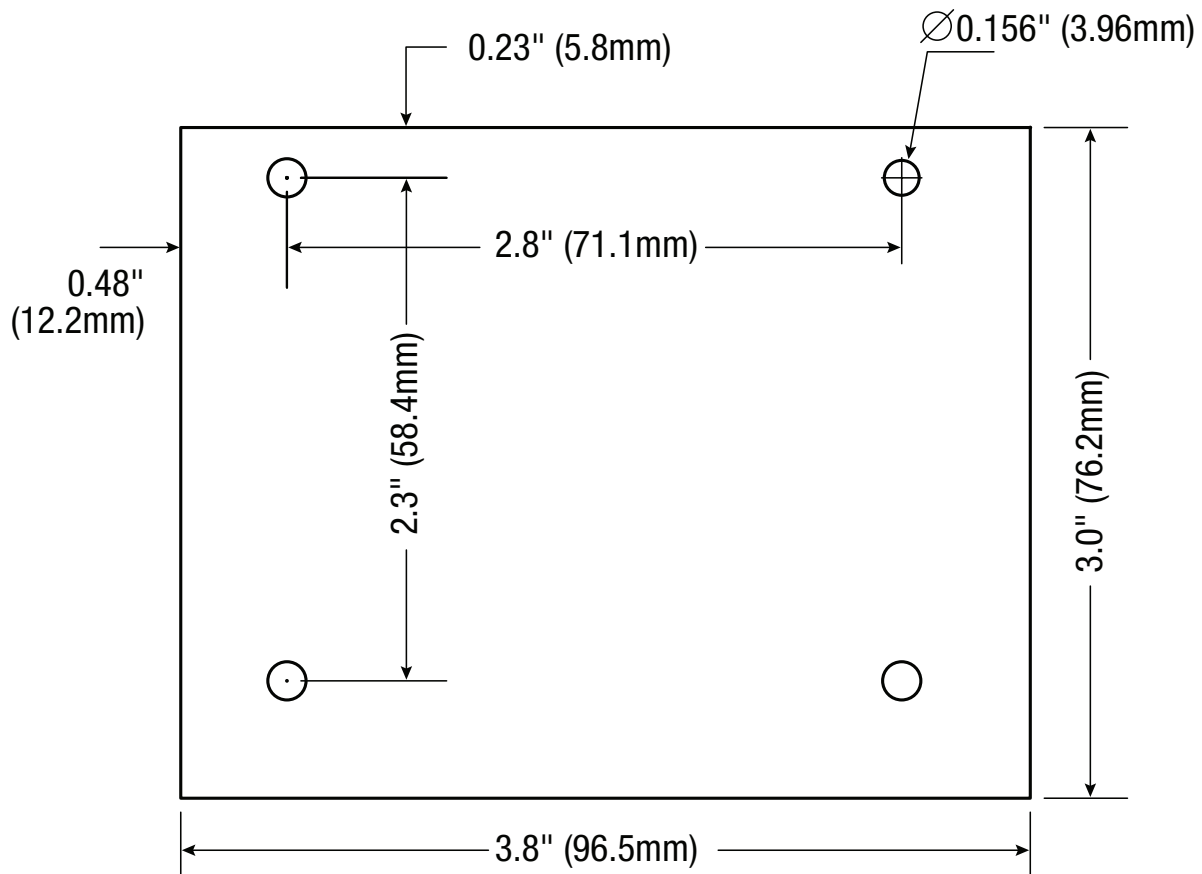
**Lifetime Warranty**

Altronix Corporation | 140 58th St | Brooklyn, NY 11220 USA

phone: +1 718.567.8181 | fax: +1 718.567.9056 | email: info@altronix.com | www.altronix.com