



ACMCB Series Access Power Controllers with Power Supplies

Installation Guide

Models Include:

- ***AL400ULACMCB***
 - *12VDC @ 4 amp
or 24VDC @ 3 amp*
 - *Class 2 Rated PTC Protected
Power Limited Outputs*
- ***AL600ULACMCB***
 - *12VDC or 24VDC @ 6 amp.*
 - *Class 2 Rated PTC Protected
Power Limited Outputs*
- ***AL1012ULACMCB***
 - *12VDC @ 10 amp.*
 - *Class 2 Rated PTC Protected
Power Limited Outputs*
- ***AL1024ULACMCB***
 - *24VDC @ 10 amp.*
 - *Class 2 Rated PTC Protected
Power Limited Outputs*

For a red enclosure, add an "R" suffix to the part # e.g. AL600ULACMCBR

Overview:

These units distribute and switch power to access control systems and accessories. They convert a 115VAC 60Hz input into eight (8) independently controlled 12VDC or 24VDC PTC protected outputs. Outputs are activated by an open collector sink or normally open (NO) dry trigger input from an Access Control System, Card Reader, Keypad, Push Button, PIR, etc. Units will route power to a variety of access control hardware devices including: Mag Locks, Electric Strikes, Magnetic Door Holders, etc. Outputs will operate in both Fail-Safe and/or Fail-Secure modes. The FACP Interface enables Emergency Egress, Alarm Monitoring, or may be used to trigger other auxiliary devices. The fire alarm disconnect feature is individually selectable for any or all of the eight (8) outputs.

ACMCB Series Configuration Reference Chart:

Altronix Model Number	12VDC Total Output Current	24VDC Total Output Current	Outputs	Individual Output Rating	Class 2 Rated Power-Limited	115VAC 60Hz Input (current draw)	Power Supply Board Input Fuse Rating	Power Supply Board Output Fuse Rating	Agency Listings	UL Listings and File Numbers
AL400ULACMCB	4A	3A	8	2A	Yes	3.5A	5A/250V	15A/32V	 	UL 294 (File # BP6714)
AL600ULACMCB	6A	6A	8	2A	Yes	3.5A	5A/250V	—		UL Listed for Access Control System Units.
AL1012ULACMCB	10A	—	8	2A	Yes	2.6A	5A/250V	15A/32V		“Signal Equipment” Evaluated to CSA Standard C22.2 No.205-M1983
AL1024ULACMCB	—	10A	8	2A	Yes	4.2A	5A/250V	15A/32V		

Specifications:

Power supply input options:

- a) One (1) common power input for ACM8CB and lock power (factory installed).
- b) Two (2) isolated power inputs (external power supply is required).
(current is determined by the power supply connected, not to exceed a maximum of 10 amp total).
- Eight (8) Access Control System trigger inputs.
Input options:
 - a) Eight (8) normally open (NO) inputs.
 - b) Eight (8) open collector inputs.
 - c) Any combination of the above.
- Eight (8) independently controlled outputs.

Output options:

- Eight (8) Fail-Safe and/or Fail-Secure power outputs.
 - Eight (8) auxiliary power outputs (unswitched) (PTC protected outputs are rated 2 amp).
 - ACM8CB board main fuse is rated at 10 amp.
 - Red LEDs indicate outputs are triggered (relays energized).
 - Fire Alarm disconnect (latching or non-latching) is individually selectable for any or all of the eight (8) outputs.
Fire Alarm disconnect input options:
 - a) Normally open (NO) or normally closed (NC) dry contact input.
 - b) Polarity reversal input from FACP signaling circuit..
 - Alarm output relay indicates that FACP input is triggered (form “C” contact rated @ 1 amp 28VDC not evaluated by UL).
 - Green LED indicates when FACP disconnect is triggered.
 - Filtered and electronically regulated outputs (built-in power supply).
 - Built-in charger for sealed lead acid or gel type batteries.
 - AL400ULXB2, AL600ULXB and AL1012ULXB (Power Supply Board) maximum charge current 0.7 amp.
AL1024ULXB2 (Power Supply Board) maximum charge current 3.6 amp.
 - Automatic switch over to stand-by battery when AC fails.
 - Zero voltage drop when unit switches over to battery backup (AC failure condition).
 - Thermal and short circuit protection with auto reset.
 - AC input and DC output LED indicators.
 - AC fail supervision (form “C” contact).
 - Battery fail and battery presence supervision (form “C” contact).
 - Enclosure accommodates up to two (2) 12AH batteries.
- Enclosure dimensions: 15.5” x 12” x 4.5” (393.7mm x 304.8mm x 114.3mm).

Installation Instructions:

Wiring methods shall be in accordance with the National Electrical Code/NFPA 70/NFPA 72/ANSI, and with all local codes and authorities having jurisdiction. Product is intended for indoor use only.

1. Mount unit in the desired location. Mark and predrill holes in the wall to line up with the top two keyholes in the enclosure. Install two upper fasteners and screws in the wall with the screw heads protruding. Place the enclosure's upper keyholes over the two upper screws; level and secure. Mark the position of the lower two holes. Remove the enclosure. Drill the lower holes and install the three fasteners. Place the enclosure's upper keyholes over the two upper screws. Install the two lower screws and make sure to tighten all screws (*Enclosure Dimensions, pg. 10*). Secure enclosure to earth ground. It is recommended to first review the following tables to facilitate installation:

Output Voltage and Stand-by Specifications Charts	(pg. 3)
Typical Application Diagram	(pg. 5)
LED Diagnostics	(pg. 5)
Terminal Identification Tables	(pg. 7)
Hook-up Diagrams	(pg. 8)

2. **Set output voltage:**

AL400ULACMCB and AL600ULACMCB set desired DC output voltage by setting switch SW1 to the appropriate position on the power supply board. AL1012ULACMCB is 12VDC and AL1024ULACMCB is 24VDC (*Output Voltage and Stand-by Specification Charts below*).

Output Voltage and Stand-by Specification Charts:

AL400ULACMCB

Voltage	Switch Position	Stand-by Battery	4 hr. Stand-by / 5 mins. Alarm	24 hr. Stand-by / 5 mins. Alarm
12VDC	SW1 - Closed	40AH	3.5 amp / 3.5 amp	1 amp / 4 amp
24VDC	SW1 - Open	40AH	2.75 amp / 2.75 amp	1 amp / 3 amp

AL600ULACMCB

Voltage	Switch Position	Stand-by Battery	4 hr. Stand-by / 5 mins. Alarm	24 hr. Stand-by / 5 mins. Alarm
12VDC	SW1 - Closed	40AH	5.5 amp / 5.5 amp	0.5 amp / 5.5 amp
24VDC	SW1 - Open	40AH	5.75 amp / 5.75 amp	0.75 amp / 5.75 amp

AL1012ULACMCB

Voltage	Switch Position	Stand-by Battery	4 hr. Stand-by / 5 mins. Alarm	24 hr. Stand-by / 5 mins. Alarm
12VDC	N/A	40AH	9.5 amp / 9.5 amp	0.5 amp / 9.5 amp

AL1024ULACMCB (refer to AL1024ULACMCB Battery Size Calculation Worksheet, pg. 9).

Voltage	Stand-by Battery	15 mins. Stand-by / 5 mins. Alarm	4 hr. Stand-by / 5 mins. Alarm	24 hr. Stand-by / 5 mins. Alarm	60 hr. Stand-by / 5 mins. Alarm
24VDC	12AH	7.7 amp / 9.7 amp	1.2 amp / 9.7 amp	—	—
24VDC	65AH	—	7.7 amp / 9.7 amp	1.2 amp / 9.7 amp	200mA / 9.7 amp

3. Measure voltage before connecting devices. This helps avoiding potential damage.
4. **Connect AC** (*Fig. 2, pg. 6*):
Connect unswitched AC power (115VAC 60Hz) to the terminals marked [L, G, N]. Use 14 AWG or larger for all power connections. Secure green wire lead to earth ground.
Keep power-limited wiring separate from non power-limited wiring (115VAC 60Hz Input, Battery Wires). Minimum 0.25" spacing must be provided.
CAUTION: Do not touch exposed metal parts. Shut branch circuit power before installing or servicing equipment. There are no user serviceable parts inside. Refer installation and servicing to qualified service personnel.

5. **Output options** (*Fig. 1, pg. 5*):

The unit will provide eight (8) switched power outputs or eight (8) unswitched auxiliary power outputs.

(a) Switched Power outputs:

Connect the negative (-) input of the device being powered to the terminal marked [COM]. For Fail-Safe operation connect the positive (+) input of the device being powered to the terminal marked [NC]. For Fail-Secure operation connect the positive (+) input of the device being powered to the terminal marked [NO].

(b) Auxiliary Power outputs (unswitched):

Connect positive (+) input of the device being powered to the terminal marked [C] and the negative (-) of the device being powered to the terminal marked [COM]. Output can be used to provide power for card readers, keypads etc.

6. **Input trigger options (Fig. 1, pg. 5):**

(a) Normally Open [NO] input trigger:

Inputs 1-8 are activated by normally open or open collector sink inputs.

Connect devices (card readers, keypads, request to exit buttons etc.) to terminals marked [IN] and [GND].

(b) Open Collector Sink inputs:

Connect the access control panel open collector sink positive (+) to the terminal marked [IN] and the negative (-) to the terminal marked [GND].

7. **Fire Alarm Interface options (Figs. 4 through 8, pg. 8):**

A normally closed [NC], normally open [NO] input or polarity reversal input from FACP signaling circuit will trigger selected outputs. To enable FACP Disconnect for an output open the corresponding switch [SW1-SW8]. To disable FACP disconnect for an output close the corresponding switch [SW1-SW8].

(a) Normally Open [NO] input:

For non-latching hook-up (Fig. 5, pg. 8). For latching hook-up (Fig. 6, pg. 8).

(b) Normally Closed [NC] input:

For non-latching hook-up (Fig. 7, pg. 8). For latching hook-up (Fig. 8, pg. 8).

(c) FACP Signaling Circuit input trigger:

Connect the positive (+) and negative (-) from the FACP signaling circuit output to the terminals marked [+ INP -]. Connect the FACP EOL to the terminals marked [+ RET -] (polarity is referenced in an alarm condition).

Jumper J3 must be cut (Fig. 4, pg. 8).

8. **FACP Dry form “C” output (Fig. 1a, pg. 5):**

Connect desired device to be triggered by the unit’s dry contact output to the terminals marked [NO] and [C] FACP for normally open output or the terminals marked [NC] and [C] FACP for normally closed output.

9. **Battery Connections (Fig. 2, pg. 6):**

For Access Control applications batteries are optional. If batteries are not used a loss of AC will result in the loss of output voltage. Batteries must be lead acid or gel type. Connect one (1) 12VDC battery to the terminals marked [- BAT +] for 12VDC operation. Use two (2) 12VDC batteries wired in series for 24VDC operation.

10. **Battery and AC Supervision output (Fig. 2, pg. 6):**

It is required to connect supervisory trouble reporting devices to outputs marked [AC Fail, BAT Fail] supervisory relay outputs marked [NC, C, NO] to appropriate notification devices. Use 22 AWG to 18 AWG for AC Fail & Low/No Battery reporting. Cut “AC delay” jumper to delay report 6 hour.

Note: A tamper switch must be installed and connected to the appropriate notification device to report a trouble condition when the enclosure door is open.

11. **Multiple power supply inputs (Fig. 1, pg. 5):**

When using two (2) power supplies jumpers J1 and J2 (located to the left of the power/control terminals) must be cut (Fig. 1b, pg. 5 & Fig. 3 pg. 8). Connect power for the ACM8CB to the terminals marked [- Control +] and connect power for the locking devices to the terminals marked [- Power +]. When using DC power supplies polarity must be observed. When using AC power supplies polarity need not be observed.

Note: For UL compliance the additional power supply must be power-limited, UL Listed for Access Control Systems and accessories.

Maintenance:

Unit should be tested at least once a year for the proper operation as follows:

Output Voltage Test: Under normal load conditions the DC output voltage should be checked for proper voltage level (Output Voltage and Stand-by Specification Charts, pg. 3).

Battery Test: Under normal load conditions check that the battery is fully charged, check specified voltage both at the battery terminals and at the board terminals marked [- BAT +] to ensure that there is no break in the battery connection wires.

Note: AL400ULXB2, AL600ULXB, AL1012ULXB (Power Supply Board) maximum charge current is 0.7 amp.

AL1024ULXB2 (Power Supply Board) maximum charge current is 3.6 amp.

Expected battery life is 5 years; however, it is recommended to change batteries within 4 years or less if necessary.

Typical Application Diagram:

Fig. 1

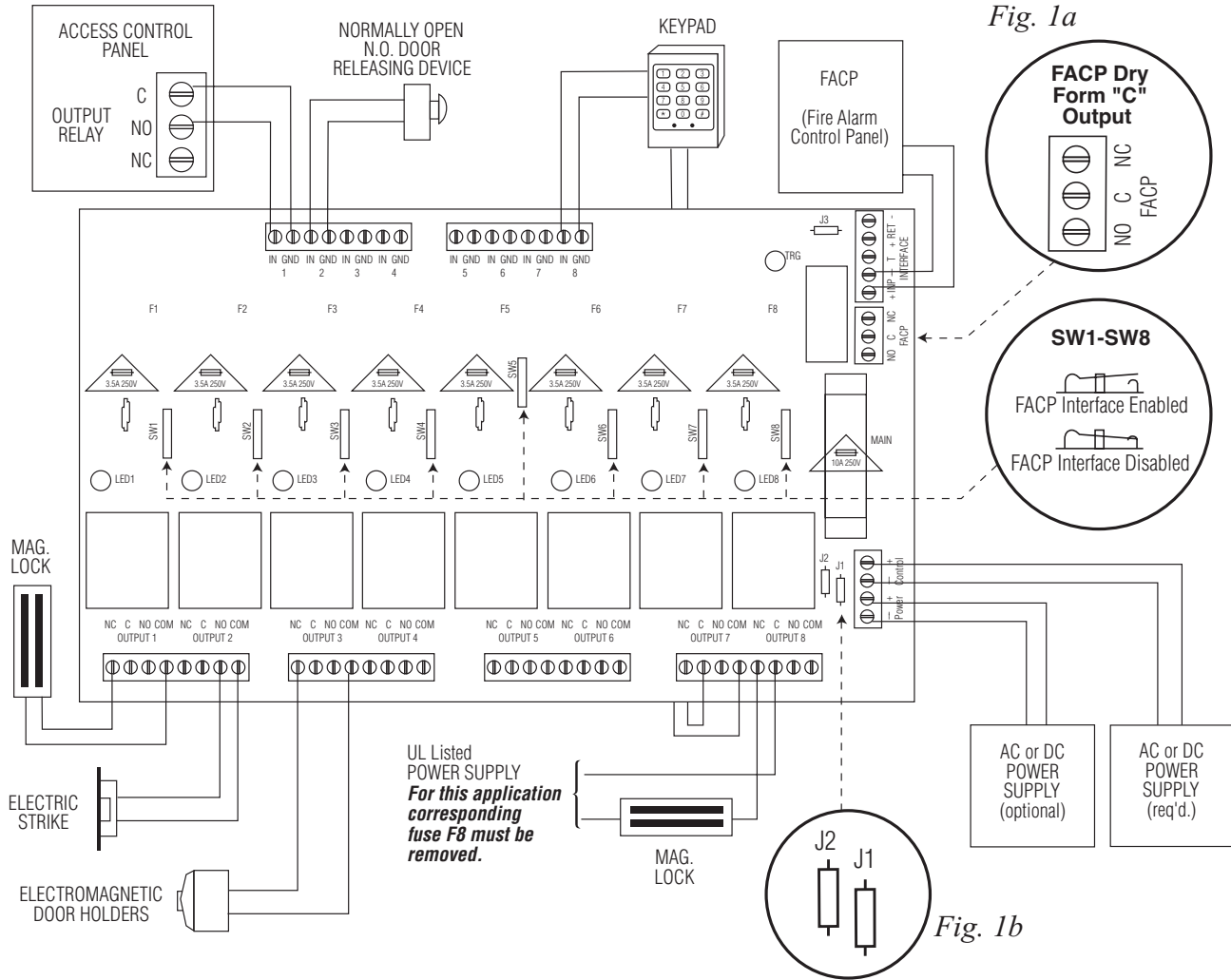

LED Diagnostics:

Power Supply Board

LED		Power Supply Status
Red (DC)	Green (AC)	
ON	ON	Normal operating condition.
ON	OFF	Loss of AC, Stand-by battery supplying power.
OFF	ON	No DC output. Short circuit or thermal overload condition.
OFF	OFF	No DC output.

Red (Bat)	Battery Status
ON	Normal operating condition.
OFF	Battery fail/low battery.

ACM8CB Access Power Controller

LED	ON	OFF
LED 1 - LED 8 (Red)	Output relay(s) energized.	Output relay(s) de-energized.
Trg (Green)	FACP input triggered (alarm condition).	FACP normal (non-alarm condition).

Fig. 2

CAUTION: De-energize unit prior to servicing. For continued protection against fire hazard replace fuse with the same type and rating.

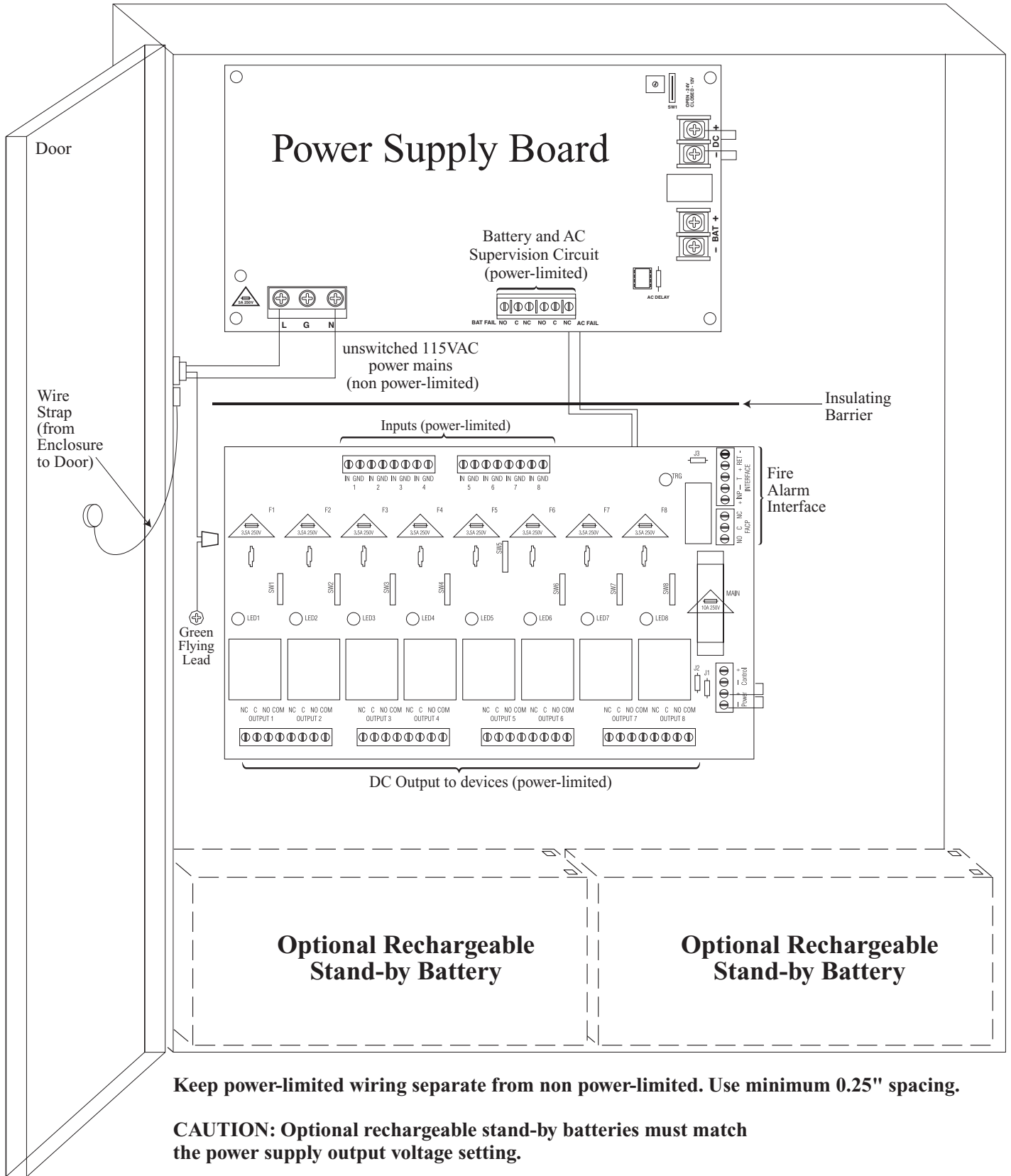

Keep power-limited wiring separate from non power-limited. Use minimum 0.25" spacing.

CAUTION: Optional rechargeable stand-by batteries must match the power supply output voltage setting.

Terminal Identification Tables:

Power Supply Board

Terminal Legend	Function/Description
L, N	Connect 115VAC 60Hz to these terminals: L to hot, N to neutral.
+ DC –	AL400ULACMCB - 12VDC @ 4 amp or 24VDC @ 3 amp to ACM8CB board (power-limited). AL600ULACMCB - 12VDC/24VDC @ 6 amp to ACM8CB board (power-limited). AL1012ULACMCB - 12VDC @ 10 amp to ACM8CB board (power-limited). AL1024ULACMCB - 24VDC @ 10 amp to ACM8CB board (power-limited).
AC FAIL NC, C, NO	Used to notify loss of AC power, e.g. connect to audible device or alarm panel. Relay normally energized when AC power is present. Contact rating 1 amp @ 28VDC. AC or brownout fail is reported within 1 minute of event. To delay reporting of up to 6 hrs., cut “AC delay” jumper and reset power to unit.
BAT FAIL NC, C, NO	Used to indicate low battery condition, e.g. connect to alarm panel. Relay normally energized when DC power is present. Contact rating 1 amp @ 28VDC. A removed battery is reported within 5 minutes. Battery reconnection is reported within 1 minute. Low battery threshold: 12VDC output threshold set @ approximately 10.5VDC (N/A for AL1024ULACMCB), 24VDC output threshold set @ approximately 21VDC (N/A for AL1012ULACMCB).
+ BAT –	Stand-by battery connections. AL400ULXB2, AL600ULXB and AL1012ULXB (Power Supply Board) maximum charge current is 0.7 amp. AL1024ULXB2 (Power Supply Board) maximum charge current is 3.6 amp.

ACM8CB Access Power Controller

Terminal Legend	Function/Description
– Power +	12VDC or 24VDC input from power supply board.
– Control +	These terminals can be connected to a separate power limited, UL listed power supply to provide isolated operating power for the ACM8CB (jumpers J1 and J2 Must be removed).
TRIGGER INPUT 1- INPUT 8 IN, GND	From normally open and/or open collector sink trigger inputs (request to exit buttons, exit pir’s, etc.).
OUTPUT 1-OUTPUT 8 NC, C, NO, COM	12 to 24 volts AC/DC trigger controlled outputs: Fail-Safe [NC positive (+) & COM Negative (-)], Fail-Secure [NO positive (+) & COM Negative (-)], Auxiliary output [C positive (+) & COM Negative (-)] (When using AC power supplies polarity need not be observed), NC, C, NO become form “C” 5 amp 24VAC/VDC rated dry outputs when fuses are removed. Contacts shown in a non-triggered state.
FACP INTERFACE T, + INPUT –	Fire Alarm Interface trigger input from FACP. Trigger inputs can be normally open, normally closed from an FACP output circuit (<i>Fig. 4 through 8, pg. 8</i>).
FACP INTERFACE NC, C, NO	Form “C” relay contact rated @ 1 amp 28VDC for alarm reporting. (This output has not been evaluated by UL).

Hook-up Diagrams:

Fig. 3 Optional hook-up using two (2) isolated power supply inputs:

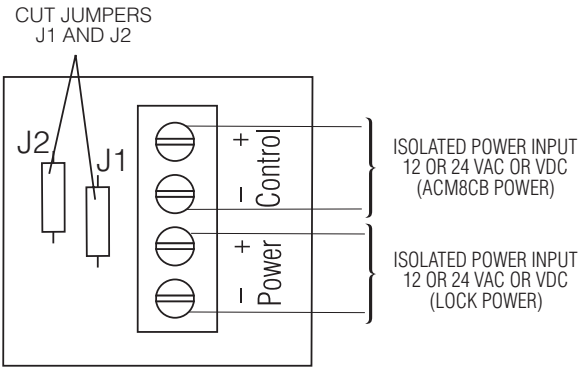

Fig. 4 Polarity reversal input from FACP signaling circuit output (polarity is referenced in alarm condition):

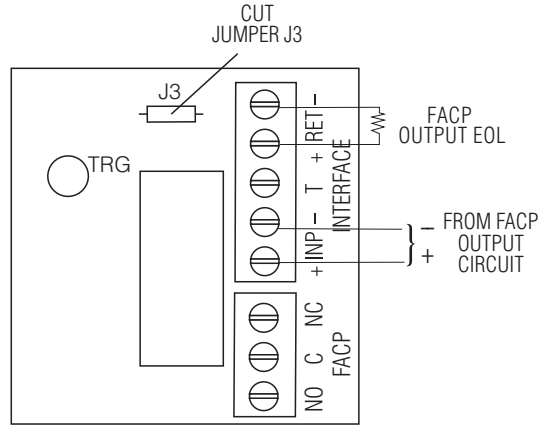

Fig. 5 Normally Open - Non-Latching FACP trigger input:

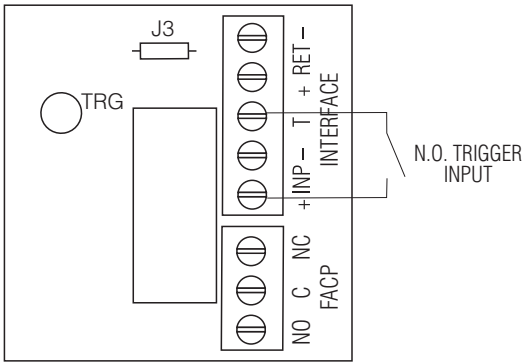

Fig. 6 Normally Open FACP Latching trigger input with reset:
(This output has not been evaluated by UL)

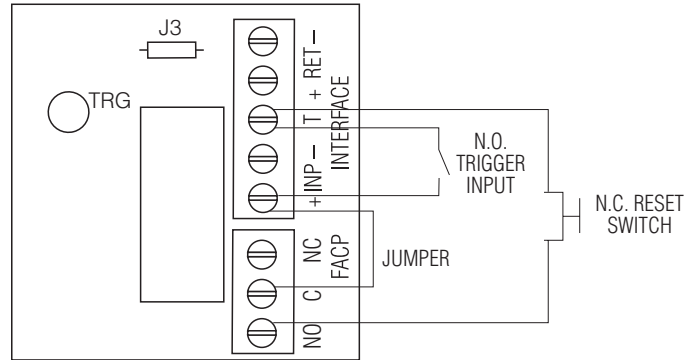

Fig. 7 Normally Closed - Non-Latching FACP trigger input:

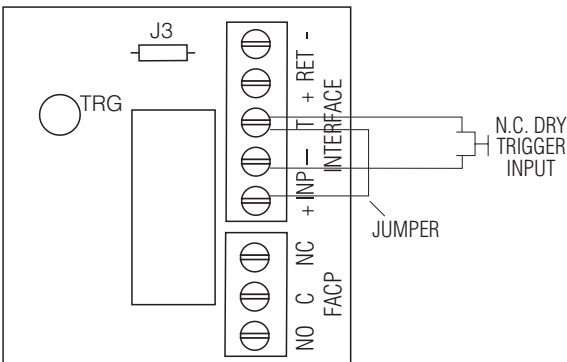
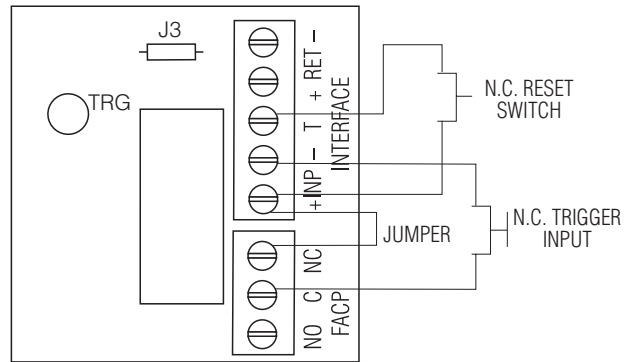

Fig. 8 Normally Closed - Latching FACP trigger input with reset:
(This output has not been evaluated by UL)



AL1024ULACMCB Battery Size Calculation Worksheet.

- A. AL1024ULACMCB internal current consumption (stand-by) _____ 0.35 A
- B. Load current consumption (stand-by) _____ A
- C. Stand-by time required (Hours) _____ H
- D. Battery capacity required for stand-by (A+B)*C _____ AH
- E. AL1024ULACMCB internal power consumption (Alarm) _____ 0.35 A
- F. Load current consumption (Alarm) _____ A
- G. Alarm duration (Hours, example: 15 Min. = 0.25 Hour) (Alarm) _____ H
- H. Battery capacity required for Alarm (E+F)*G _____ AH
- I. Total calculated battery capacity D+H _____ AH
- J. Battery capacity required I*1.8 (safety factor) _____ AH

Note: AL1024ULACMCB power supply is designed to work with batteries up to 65AH. Please note, line [I] must not exceed 36AH. You have to reduce either stand-by current consumption or stand-by time in order to comply with requirement.

To determine actual battery size please round line [J] to the nearest larger standard battery size.

Enclosure Dimensions (H x W x D approximate):
 15.5" x 12" x 4.5" (393.7mm x 304.8mm x 114.3mm)

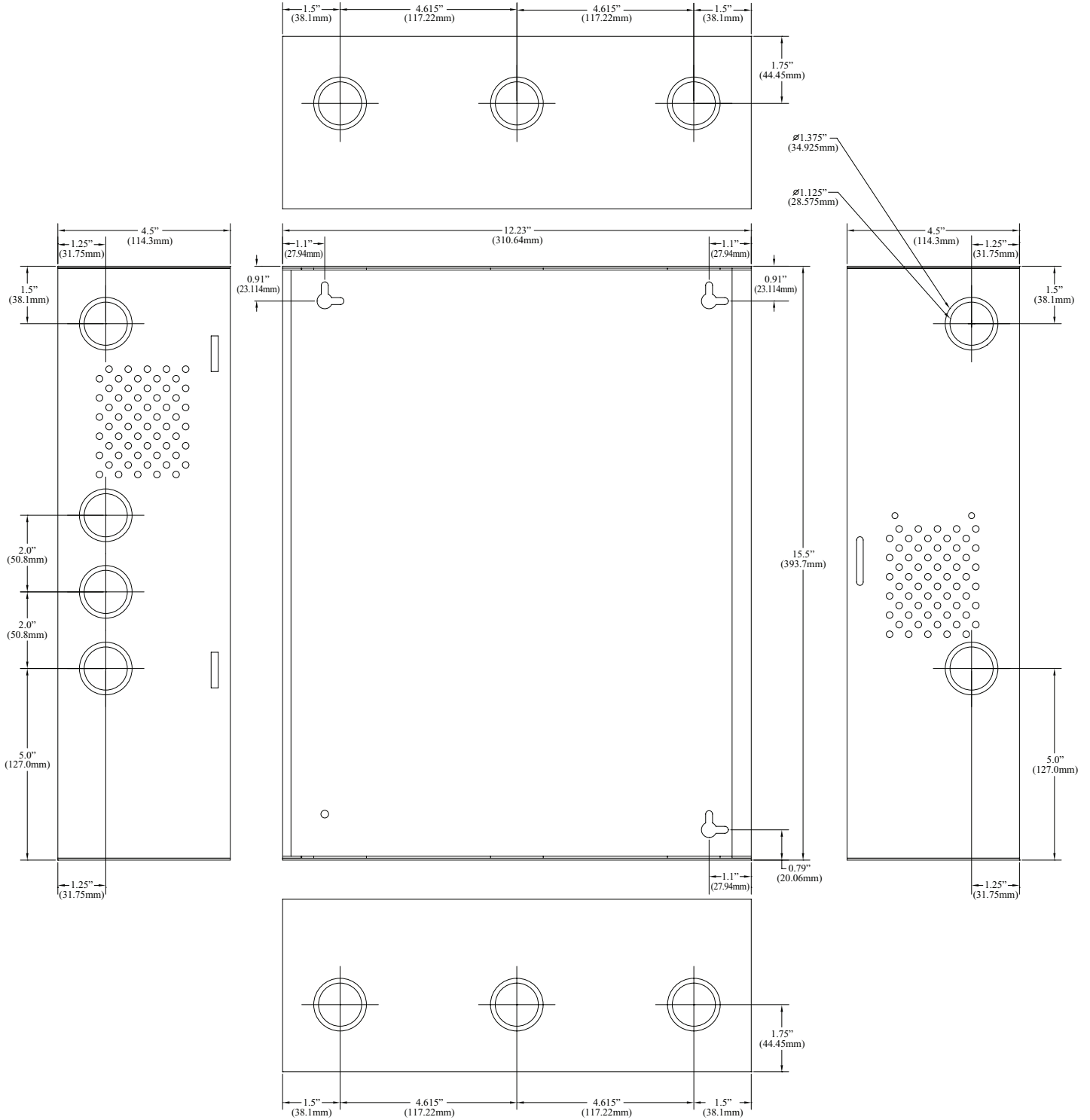

Notes:

Notes:

Altronix is not responsible for any typographical errors.

140 58th Street, Brooklyn, New York 11220 USA, 718-567-8181, fax: 718-567-9056
web site: www.altronix.com, e-mail: info@altronix.com, Lifetime Warranty, Made in U.S.A.
IIACMCB series

G01N

- 12 -

