

# AL175220 Series

## Access Control Power Supply/Chargers

### Models Include:

#### AL175220

- Enclosure Dimensions: 8.5" x 7.5" x 3.5" (215.9mm x 190.5mm x 88.9mm).
- Accommodates one (1) 12VDC/4AH battery.

#### AL175X220

- Enclosure Dimensions: 13.5" x 13" x 3.25" (342.9mm x 330.2mm x 82.6mm).
- Accommodates up to two (2) 12VDC/7AH Batteries.

## Installation Guide



**More than just power.™**

Rev. 011316

Installing Company: \_\_\_\_\_ Service Rep. Name: \_\_\_\_\_

Address: \_\_\_\_\_ Phone #: \_\_\_\_\_

## Overview:

Altronix AL175220 and AL175X220 are power-limited power supply/chargers that converts 220VAC (working range 198VAC - 256VAC), 50/60Hz input into two individually PTC protected auto-resettable 12VDC or 24VDC outputs (see specifications). They are intended for use in Access Control applications and applications requiring an interface with the Fire Alarm Control Panels. They must be installed in accordance with National and Local Electrical Codes and Regulations.

## Specifications:

### Input:

- Input 220VAC, 50/60 Hz, 0.3A.

### Output:

- 12VDC or 24VDC selectable output.
- Power-limited outputs.
- 1.75A continuous supply current @ 12VDC or 24VDC.
- Aux relay output (form "C" contacts).
- Filtered and electronically regulated output.
- Short circuit and thermal overload protection.

### Battery Backup:

- Maximum charge current: 400mA.
- Automatic switch over to stand-by battery when AC fails.

### Supervision:

- AC fail supervision (form "C" contacts).
- Dry trigger output (form "C" contacts).

### Fire Alarm Interface:

- Dry trigger input.

### Visual Indicators:

- AC input and DC output LED indicators.

### Added Features:

- Includes power supply, transformer, and enclosure.

### Enclosure Dimensions:

#### AL175220:

8.5" x 7.5" x 3.5" (215.9mm x 190.5mm x 88.9mm).

#### AL175X220:

13.5" x 13" x 3.25"

(342.9mm x 330.2mm x 82.6mm).

## Power Supply Output Specifications:

Output VDC	Switch Position	Max. Stand-by Load DC	Max. Alarm Load DC	Battery (optional)
12VDC	SW1 OFF	1.75A	1.75A	12VDC
24VDC	SW1 ON	1.75A	1.75A	Two (2) 12VDC

## Stand-by Specifications:

Output	4 hr. of Stand-by and 5 Minutes of Alarm
12VDC / 7 AH Battery	Stand-by = 1.25A
24VDC / 7 AH Battery	Alarm = 1.25A

## Installation Instructions:

The units should be installed in accordance with article 760 of The National Electrical Code or NFPA 72 as well as all applicable Local Codes.

See **Terminal Identification Chart** on *Pg. 3* for a description of each terminal function.

1. Mount unit in the desired location. Mark and predrill holes in the wall to line up with the top two keyholes in the enclosure. Install two upper fasteners and screws in the wall with the screw heads protruding. Place the enclosure's upper keyholes over the two upper screws; level and secure. Mark the position of the lower two holes. Remove the enclosure. Drill the lower holes and install two fasteners. Place the enclosure's upper keyholes over the two upper screws. Install the two lower screws and make sure to tighten all screws (**Enclosure Dimensions, pgs. 7-8**).
2. Connect unswitched AC circuit (220VAC, 50/60Hz) as follows: Green branch wire (ground) connects to the terminal marked  $\ominus$ , Line connects to the terminal marked [L], and Neutral connects to the terminal marked [N] of the Inlet Appliance Connector. (*Fig. 1, pg. 4*).  
Use 18 AWG or larger for all power connections.  
Use 18 AWG or larger for all power connections (Battery, AC input, DC outputs).  
Use 22 AWG to 18 AWG for power-limited circuits (trigger inputs, dry outputs).

Keep power-limited wiring separate from non power-limited wiring (220VAC, 50/60Hz Input, Battery Wires). Minimum 0.25" spacing must be provided.

**CAUTION: Do not touch exposed metal parts.**

**Shut branch circuit power before installing or servicing equipment.**

**There are no user serviceable parts inside. Refer installation and servicing to qualified service personnel.**

3. Set the unit to the desired DC output voltage by setting switch SW1 to the appropriate position

(**Power Supply Output Specification Table**, *pg. 2*).

4. Measure output voltage before connecting devices. This helps avoiding potential damage.

5. Connect battery to the terminals marked [+ BAT -] (battery leads included).

Use two (2) 12VDC batteries connected in series for 24VDC operation.

**Note:** For Access Control applications batteries are optional. When batteries are not used, a loss of AC will result in the loss of output voltage. When the use of stand-by batteries is desired, they must be lead acid or gel type.

6. Connect appropriate signaling notification devices to AC Fail supervisory relay outputs marked [NC, NO, C].

7. For Access Control Device & Fire Alarm Interface connections refer to the desired **Application Diagrams**

(*pgs. 5-6*) and **Terminal Identification Chart** (*pg. 3*).

## **Maintenance:**

Unit should be tested at least once a year for the proper operation as follows:

**Output Voltage Test:** Under normal load conditions the DC output voltage should be checked for proper voltage level (see *Power Supply Output Specifications Chart*).

**Battery Test:** Under normal load conditions check that the battery is fully charged, check specified voltage both at the battery terminal and at the board terminals marked [+ BAT -] to ensure that there is no break in the battery connection wires.

**Note:** Maximum charging current under discharges is 400mA.

**Note:** Expected battery life is 5 years; however, it is recommended changing batteries in 4 years or less if needed.

Fig. 1 - AL175220 Series

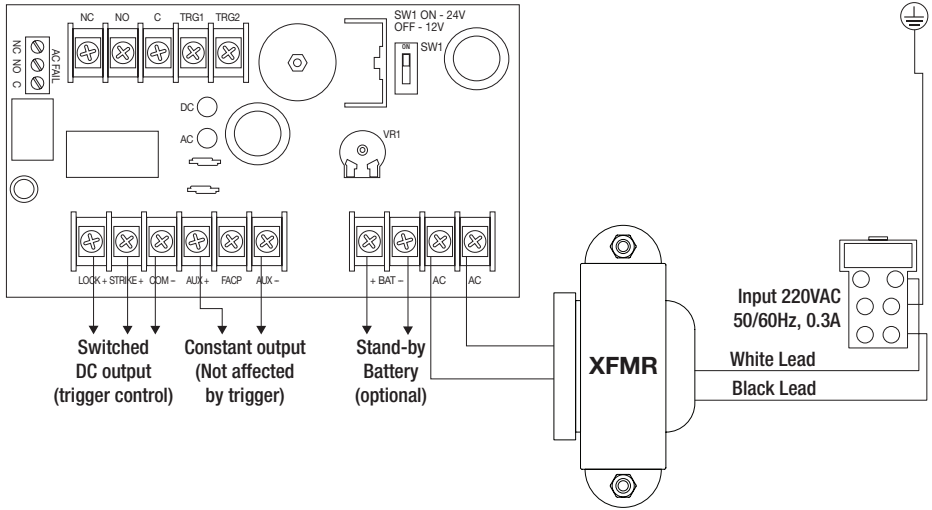

### LED Diagnostics:

Red (DC)	Green (AC)	Power Supply Status
ON	ON	Normal function.
ON	OFF	Battery backup is powering output.
OFF	ON	No DC output.
OFF	OFF	Loss of AC. Discharged or missing stand-by battery. No DC output.

### Terminal Identification:

Terminal Legend	Function/Description
TRG1 & TRG2	Connects to the normally closed outputs of an access control or fire alarm relay. These terminals control [LOCK +], and [STRIKE +], as well as AL175(X)220 output relay contacts [NC, NO, C].
LOCK +	Provides DC output voltage when [TRG1] and [TRG2] are shorted together and are typically used to power Mag Locks.
STRIKE +	Provides DC output voltage when [TRG1] and [TRG2] are unshorted and are typically used to power Electric Strikes.
NC, NO, C	Isolated dry form "C" contacts. Shorting [TRG1] and [TRG2] together causes these contacts to switch. They are typically used for controlling multiple AL175(X)220s with fire alarm tie-in (Fig. 5 and Fig. 6, pg. 6).
AUX +	Continuous positive (+) DC power output voltage. It is not affected by TRG1, TRG2 operation.
COM -	Common negative (-) output (ground).
FACP	Spare wiring terminal used for fire alarm tie-in application (Fig. 4, pg. 6).
+ BAT -	Stand-by battery connections.
AC FAIL NC, C, NO	Indicates loss of AC, e.g connect audible device or alarm panel. Relay normally energized when AC power is present. Contact rating 1A @ 28VDC.

## Typical Application Diagrams:

Fig. 2 Typical single mag lock or door strike installation with fire alarm tie-in using trigger controlled output:

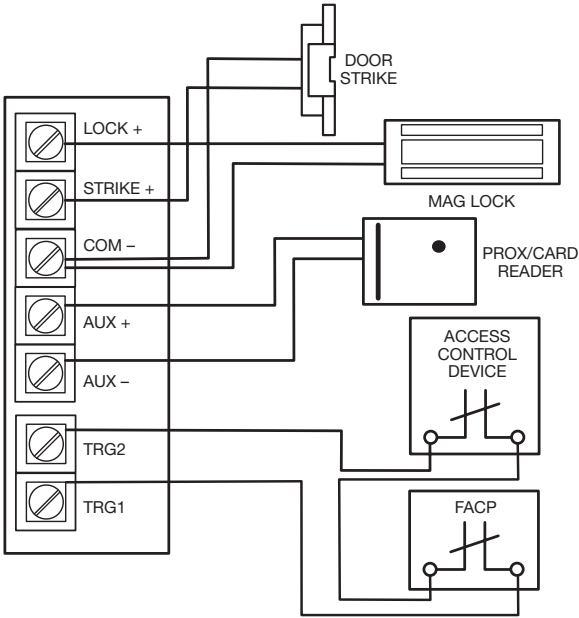
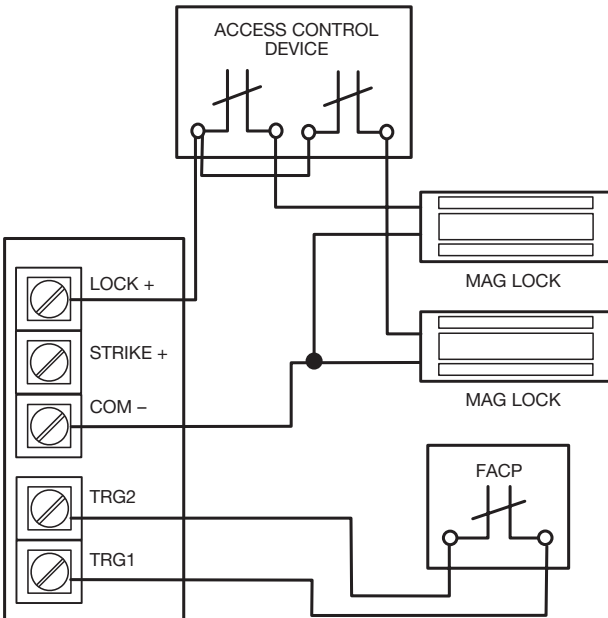

Fig. 3 Typical dual mag lock installation with fire alarm tie-in using trigger controlled outputs:



## Typical Application Diagrams:

Fig. 4 Typical mag lock with fire alarm tie-in using aux output installation:

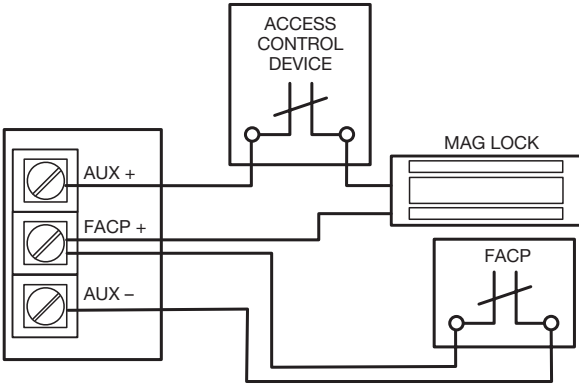

Fig. 5 Latching fire alarm tie-in with manual reset:

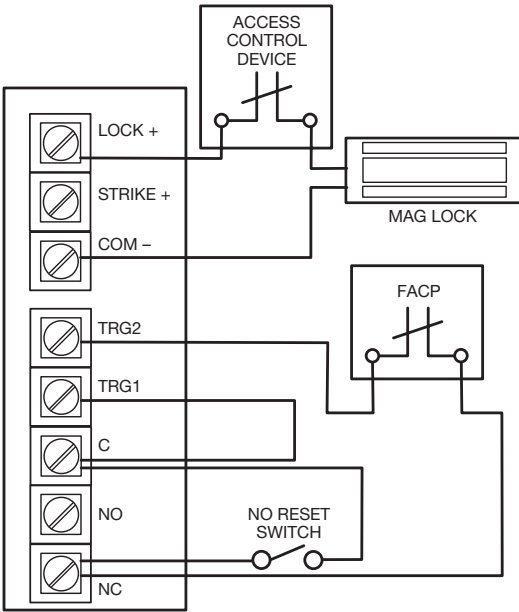
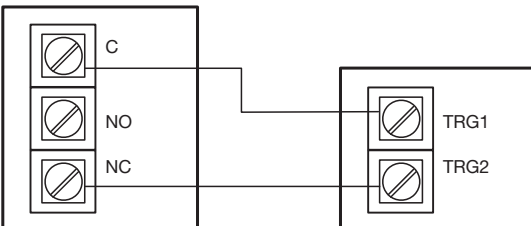

Fig. 6 Multiple AL175(X)220 power supply connections:



# Enclosure Dimensions (H x W x D approximate):

AL175220

8.5" x 7.5" x 3.5" (215.9mm x 190.5mm x 88.9mm).

Accommodates one (1) 12VDC/4AH battery.

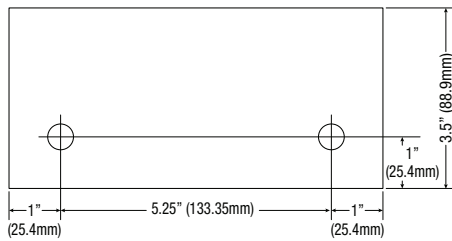
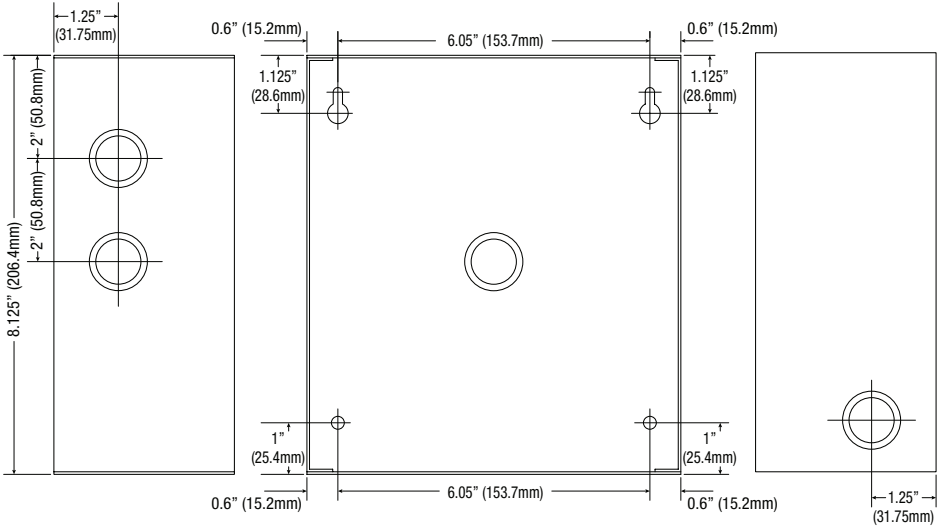
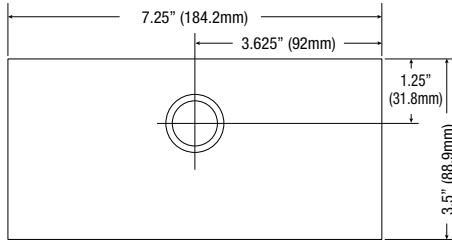

# Enclosure Dimensions (H x W x D approximate):

## AL175X220

13.5" x 13" x 3.25" (342.9mm x 330.2mm x 82.55mm)

Accommodates up to two (2) 12VDC/7AH batteries.

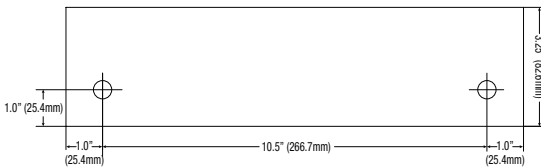
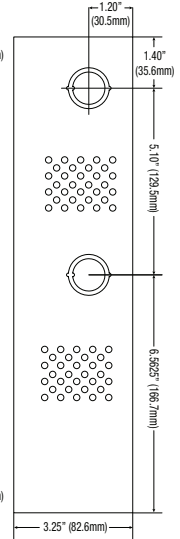
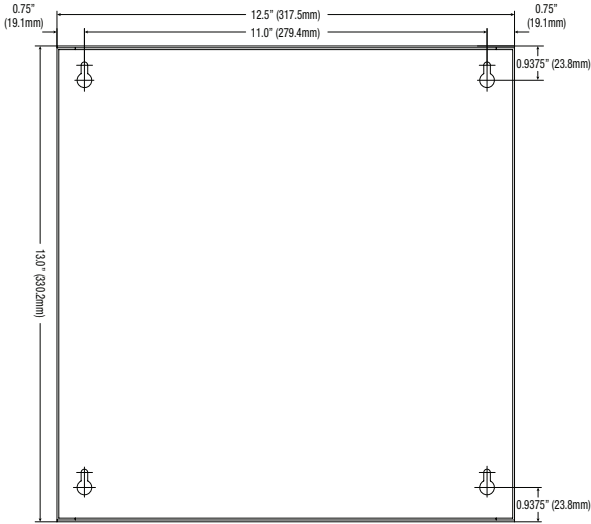
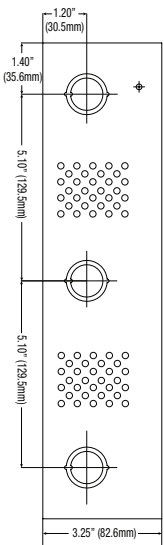
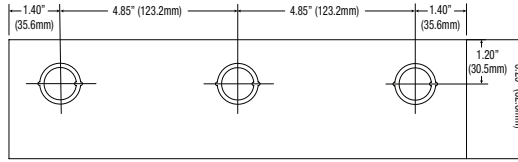

Altronix is not responsible for any typographical errors.

140 58th Street, Brooklyn, New York 11220 USA | phone: 718-567-8181 | fax: 718-567-9056  
website: [www.altronix.com](http://www.altronix.com) | e-mail: [info@altronix.com](mailto:info@altronix.com) | Lifetime Warranty  
IAL175220 Series F30U

