

AL300X220 Series

Power Supply/Charger

Models Include:

AL300X220

- Single Output.

AL300PD4220

- Four (4) Fuse Protected Outputs.

AL300PD8220

- Eight (8) Fuse Protected Outputs.

AL300XPD16220

- Sixteen (16) Fuse Protected Outputs.

AL300PD4CB220

- Four (4) PTC Protected Outputs.

AL300PD8CB220

- Eight (8) PTC Protected Outputs.

AL300XPD16CB220

- Sixteen (16) PTC Protected Outputs.

For a red enclosure add an “R” suffix to the part #, e.g. **AL300PD8R220**
For a larger enclosure add an “X” suffix to the part #, e.g. **AL300XPD8220**

Installation Guide



Rev. 062206

More than just power.™

Installing Company: _____ Service Rep. Name: _____

Address: _____ Phone #: _____

Overview:

Altronix AL300X220 is a power supply that converts a nominal 220VAC (working range 198VAC - 256VAC), 50/60Hz input to a 12VDC or 24VDC regulating output (see specifications below).

The AL300X220 is a base power supply unit for multi-output power supply/charger series:

AL300PD4220, AL300PD4CB220, AL300PD8220, AL300PD8CB220, AL300XPD16220, AL300XPD16CB220 (Refer to **AL300X220 Series Power Supply Configuration Reference Chart** below).

AL300X220 Series Power Supply Configuration Reference Chart:

Altronix Model Number	Accessory Power Distribution Module(s)	Number of Outputs	Fused Outputs	PTC Outputs (auto-resettable)	12VDC or 24VDC Total Output Current (A)	Individual Output Rating (A)	Power Supply Input Fuse Rating	Power Supply Battery Fuse Rating	Accommodates Stand-by Batteries
AL300X220	-	1	-	-	2.5A	2.5A	5A/250V	15A/32V	Two (2) 12VDC/7AH
AL300XX220									Two (2) 12VDC/12AH
AL300PD4220	PD4	4	✓	-	2.5A	2.5A			Two (2) 12VDC/7AH
AL300XPD4220									Two (2) 12VDC/12AH
AL300PD4CB220	PD4CB		-	✓	2.5A	2.5A			Two (2) 12VDC/7AH
AL300XPD4CB220									Two (2) 12VDC/12AH
AL300PD8220	PD8	8	✓	-	2.5A	2.5A			Two (2) 12VDC/7AH
AL300XPD8220									Two (2) 12VDC/12AH
AL300PD8CB220	PD8CB		-	✓	2.5A	2.5A			Two (2) 12VDC/7AH
AL300XPD8CB220									Two (2) 12VDC/12AH
AL300XPD16220	Two (2) PD8	16	✓	-	2.5A	2.5A			Two (2) 12VDC/12AH
AL300XPD16CB220	Two (2) PD8CB								Two (2) 12VDC/12AH

Specifications:

Agency Listing:

- CE European Conformity.

Input:

- Nominal 220VAC (working range 198 - 256VAC), 50/60Hz, 1.7A.
- AC input and DC output LED indicators.

Output:

- 12VDC or 24VDC selectable output(s).
- 2.5A total supply current.
- Filtered and electronically regulated output(s).
- Short circuit and thermal overload protection.

Battery Backup:

- Built-in charger for sealed lead acid or gel type batteries.
- Automatic switch over to stand-by battery when AC fails.
- Maximum charge current 0.7A.
- Zero voltage drop when switched over to battery backup.

Supervision:

- AC fail supervision (form "C" contacts).
- Low battery supervision (form "C" contacts).
- Battery presence supervision (form "C" contacts).

Additional Features:

- Power supply, enclosure, cam lock and battery leads.
- All models are available in red enclosure (add an "R" suffix to the part #, e.g. AL300PD8R220).

Enclosure Dimensions:

AL300X220, AL300PD4220, AL300PD4CB220,

AL300PD8220, AL300PD8CB220:

13.5" x 13" x 3.25"
(342.9mm x 330.2mm x 82.6mm).

AL300XX220, AL300XPD4220,
AL300XPD8220, AL300XPD16220,
AL300XPD4CB220, AL300XPD8CB220,
AL300XPD16CB220:

15.5" x 12" x 4.5"
(393.7mm x 304.8mm x 114.3mm).

Power Supply Output Specifications:

Output	Switch Position
12VDC	SW1 - ON
24VDC	SW1 - OFF



OFF - 24V
ON - 12V

Stand-by Specifications (total current shown):

Output	4 hr. of Stand-by and 5 Minutes of Alarm	24 hr. of Stand-by and 5 Minutes of Alarm	60 hr. of Stand-by and 5 Minutes of Alarm
12VDC / 40AH Battery	Stand-by = 2.5A Alarm = 2.5A	Stand-by = 1.0A Alarm = 2.5A	Stand-by = 300mA Alarm = 2.5A
24VDC / 12AH Battery	—	Stand-by = 200mA Alarm = 2.5A	—
24VDC / 40AH Battery	Stand-by = 2.5A Alarm = 2.5A	Stand-by = 1.0A Alarm = 2.5A	Stand-by = 300mA Alarm = 2.5A

Fig. 1 - AL300X220

CAUTION: De-energize unit prior to servicing. For continued protection against risk of electric shock and fire hazard replace fuse with the same type and rating. Do not expose to rain or moisture.

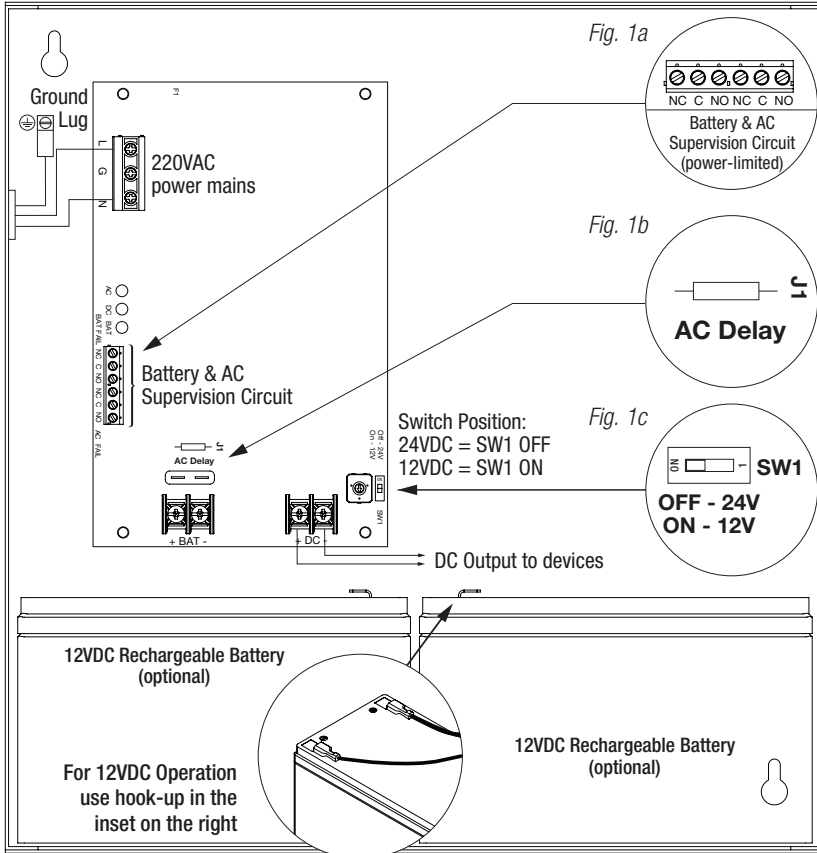

CAUTION: When power supply board is set for 12VDC use only one (1) 12VDC stand-by battery. Keep power-limited wiring separate from non power-limited. Use minimum 0.25" spacing.

Installation Instructions:

Wiring methods should be in accordance with the National Electrical Code/NFPA 70/NFPA 72/ANSI and with all local codes and authorities having jurisdiction. Product is intended for indoor use only.

1. Mount unit in the desired location. Mark and predrill holes in the wall to line up with the top two keyholes in the enclosure. Install two upper fasteners and screws in the wall with the screw heads protruding. Place the enclosure's upper keyholes over the two upper screws; level and secure. Mark the position of the lower two holes. Remove the enclosure. Drill the lower holes and install two fasteners. Place the enclosure's upper keyholes over the two upper screws. Install the two lower screws and make sure to tighten all screws (*Enclosure Dimensions, pg. 7,8*). Secure enclosure to earth ground.
2. Set the unit to the desired DC output voltage by setting SW1 (*Fig. 1c, pg. 3*) to the appropriate position (**Power Supply Voltage Output Selections Chart, pg. 3**).
3. Connect AC circuit (220VAC, 50/60Hz) as follows: Green branch wire connects to earth (safety) ground lug . Line and Neutral to the connector on power supply board marked [L, N] respectively (*Fig. 1, pg. 3*). Use 14 AWG or larger for all power connections (Battery, DC output, AC input). Use 22 AWG to 18 AWG for power-limited circuits (AC Fail/Low Battery reporting).
Keep power-limited wiring separate from non power-limited wiring (220VAC 50/60Hz Input, Battery Wires). Minimum 0.25" spacing must be provided.
CAUTION: Do not touch exposed metal parts. Shut branch circuit power before installing or servicing equipment. There are no user serviceable parts inside. Refer installation and servicing to qualified service personnel.
4. Measure output voltage before connecting devices. This helps avoiding potential damage. When servicing the unit, AC mains should be removed.
5. Connect devices to be powered:
 - a. For AL300X220 Power Supply: connect devices to the terminals marked [+ DC -] (*Fig. 1, pg. 3*).
 - b. For other Power Distribution Models: connect devices to be powered to the terminal pairs 1 to 4 marked [1P & 1N] through [4P & 4N] (*Fig. 2a & 2b, pg. 6*) or 1 to 8 marked [1P & 1N] through [8P & 8N] (*Fig. 3a & 3b, pg. 6*), carefully observing correct polarity.
6. For Access Control applications batteries are optional. When batteries are not used, a loss of AC will result in the loss of output voltage. When the use of stand-by batteries is desired, they must be lead acid or gel type. Connect one (1) 12VDC battery to the terminals marked [+ BAT -] for 12VDC operation. Use two (2) 12VDC batteries wired in series for 24VDC operation.
7. Connect appropriate signaling notification devices to the terminals marked [AC FAIL & BAT FAIL] (*Fig. 1a, pg. 3*) supervisory relay outputs.
Note: When used in fire alarm, burglar alarm or access control applications, "AC Fail" relay must be used to provide a visual indication of AC power on. To delay report for 6 hours cut "AC Delay" jumper (*Fig. 1b, pg. 3*).
8. Please ensure that the cover is secured with the provided Key Lock.

LED Diagnostics:

Power Supply Board

Red (DC)	Green (AC)	Power Supply Status
ON	ON	Normal operating condition.
ON	OFF	Loss of AC. Stand-by battery supplying power.
OFF	ON	No DC output.
OFF	OFF	Loss of AC. Discharged or no stand-by battery. No DC output.

Red (Bat)	Battery Status
ON	Normal operating condition.
OFF	Battery fail/low battery.

Power Distribution Module

Green	Power Distribution Module Status
ON	Normal operating condition.
OFF	No Power Output.

Terminal Identification:

Power Supply Board

Terminal Legend	Function/Description
L, G, N	Connect 220VAC (working range 198VAC - 256VAC), 50/60Hz to these terminals: L to Hot, N to Neutral. Do not use the [G] terminal.
+ DC -	12VDC or 24VDC @ 2.5A continuous power-limited output.
AC Fail NC, C, NO	Indicates loss of AC power, e.g. connect to annunciator/alarm panel. Relay normally energized when AC power is present. Contact rating 1A @ 28VDC. AC Fail condition will report approximately within one (1) minute after loss of AC. To delay report for 6 hours cut jumper J1 on the Power Supply Board (AC trouble output delay option). If this mode is selected, the Power Supply Board must be reset by removing all power to it for 30 seconds.
Bat Fail NC, C, NO	Indicates low battery condition, e.g. connect to alarm panel. Relay normally energized when DC power is present. Contact rating 1A @ 28VDC. Low battery conditions will report approximately 21VDC (24VDC output setting) or approximately 10.5VDC (12VDC output setting). Battery presence detection will report approximately 1 minute after battery remains undetected (missing or removed).
+ BAT -	Stand-by battery connections. Maximum charge current 0.7A.

Power Distribution Module

Terminal Legend		Function/Description
PD4/PD4CB	PD8/PD8CB	
1P to 4P	1P to 8P	Positive DC power outputs.
1N to 4N	1N to 8N	Negative DC power outputs.

Power Distribution Module(s):

Fig. 2a - PD4 Power Distribution Board
Fuse Protected Outputs

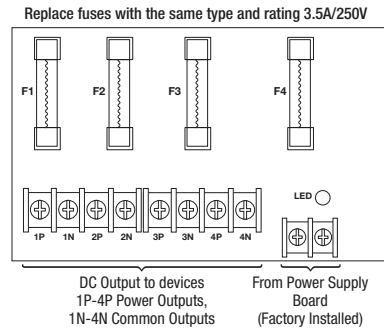

Fig. 2b - PD4CB - Power Distribution Board
PTC Protected Outputs

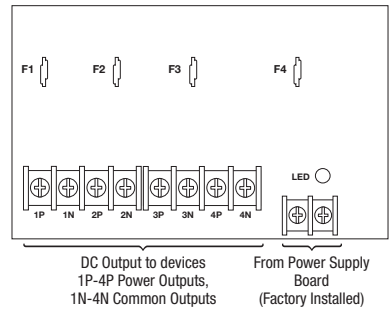

Fig. 3a - PD8 Power Distribution Board
Fuse Protected Outputs

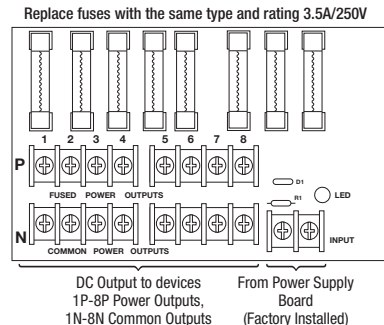
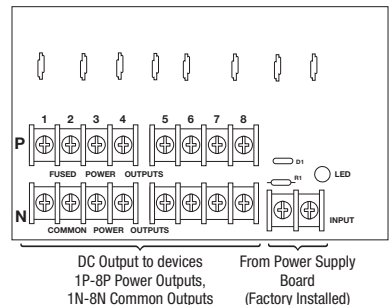

Fig. 3b - PD8CB - Power Distribution Board
PTC Protected Outputs



Wiring:

Use 14 AWG or larger for all power connections.

Note: Take care to keep power-limited circuits separate from non power-limited wiring (220VAC, Battery).

Maintenance:

Unit should be tested at least once a year for the proper operation as follows:

Output Voltage Test: Under normal load conditions the DC output voltage should be checked for proper voltage level (**Power Supply Voltage Output Specifications Chart**, *pg. 3*).

Battery Test: Under normal load conditions check that the battery is fully charged, check specified voltage both at the battery terminal and at the board terminals marked [+ BAT -] to ensure that there is no break in the battery connection wires.

Note: Maximum charging current under discharges is 0.7A.

Note: Expected battery life is 5 years; however, it is recommended changing batteries in 4 years or less if needed.

Enclosure Dimensions (BC300):

AL300X220, AL300XR220, AL300PD4220, AL300PD4CB220, AL300PD8220, AL300PD8CB220

13.5" x 13" x 3.25" (342.9mm x 330.2mm x 82.6mm)

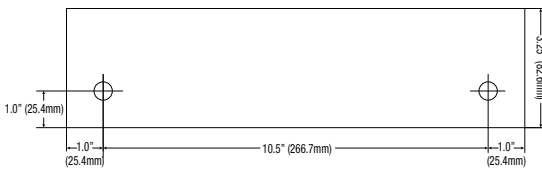
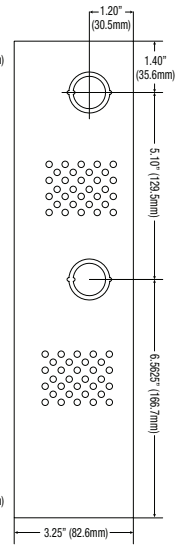
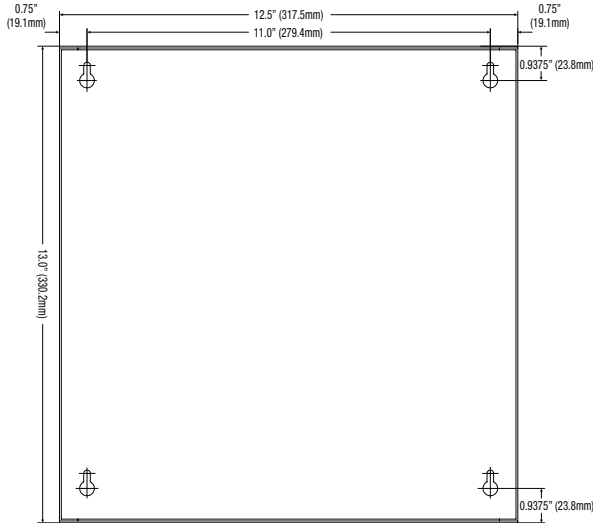
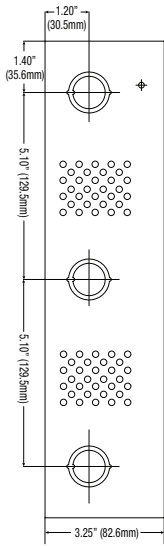
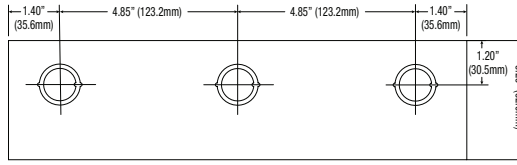

Enclosure Dimensions (BC400):

AL300XX220, AL300XXR220, AL300XPD4220, AL300XPD4CB220,

AL300XPD8220, AL300XPD8CB220, AL300XPD16220, AL300XPD16CB220

15.5" x 12" x 4.5" (393.7mm x 304.8mm x 114.3mm)

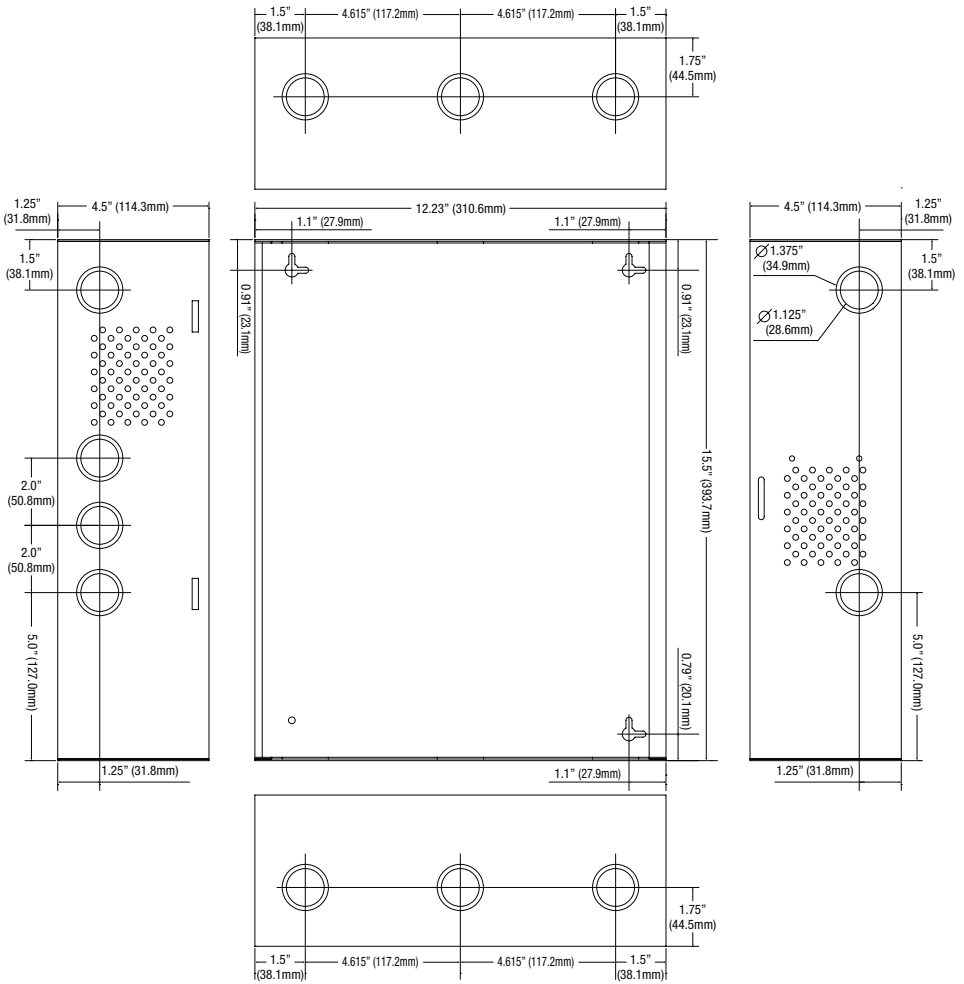

Altronix is not responsible for any typographical errors.

140 58th Street, Brooklyn, New York 11220 USA | phone: 718-567-8181 | fax: 718-567-9056

website: www.altronix.com | e-mail: info@altronix.com | Lifetime Warranty

IIL300X220 Series

G02U



MEMBER