



# eBridge™

## eBridge1CR IP over Coax Receiver Installation Guide



### Overview:

eBridge1CR is a CAT5 to Coax cable Ethernet adapter. The receiver enables fast 10/100Base-T Ethernet digital communication to be received over Coax cable. This plug and play unit facilitates system upgrades from analog to IP cameras/devices utilizing existing legacy Coax and eliminating the costs and labor associated with installing new network cabling. In addition data transmission over the Coax can be extended to 500m (five times the 100m Ethernet maximum length), eliminating the need for repeaters. At the same time the unit can combine composite video signal with the Ethernet data enabling connection to an analog input on a monitor or matrix switch.

**eBridge1CR is to be used with a compatible Sony Hybrid cameras with “sloc” technology.**  
**eBridge1CT is required for other IP cameras/devices.**

### Features:

#### Agency Listings:

- UL/CUL Listed for Information Technology Equipment (UL 60950-1).
- CE approved.
- C-Tick compliant.

#### sloc™ Compliant:

- Incorporates \*sloc™ (Security Link over Coax) technology.

#### Input:

- 12VDC to 24VDC Class 2 power supply (polarity not observed) or 16VAC to 24VAC Class 2 plug-in transformer.

#### Power Consumption:

- 12VDC/275mA, 24VDC/110mA, 16VAC/375mA, 24VAC/200mA.

#### Ethernet:

- Connectivity: RJ45, auto-crossover.
- Wire type: 4-pair CAT5 or better structured cable.
- Distance: up to 100m.
- Speed: 10/100BaseT, half/full duplex, auto negotiation.
- Throughput is rated to pass 25Mbps of data at distances up to 500m. With proper headend equipment multiple Megapixel cameras can be used.

#### LED Indicators:

- Blue LED - Coax link connection.
- Yellow and Green LED (RJ45) IP Link status, 10/100Base-T/active.
- Green LED - Power.

#### Coax:

- Distance: up to 500m.
- Connectivity: BNC, RG-59/U or similar.

#### Environmental:

- Operating Temperature: 14°F to 122°F (– 0°C to 50°C).
- Storage Temperature: – 22°F to 158°F (– 30°C to 70°C).
- Humidity: 20 to 85%, non-condensing.

#### Accessories:

- Composite video cables (included) - enables simultaneous composite video signal over the same Coax.
- Two (2) power connectors.

#### Applications:

- Retrofit digital IP cameras in an analog CCTV installation.
- Works with Megapixel, HD720, HD1080 and VGA (SD) cameras (*see note, pg. 2*).
- Extend Network link distance in an industrial environment.
- Upgrade deployed CCTV Coax to a digital network in Retail, Hospitality, Arenas, Casinos, Airports, Schools, Hospitals, Transportation, etc.
- Enables simultaneous transmission of composite and digital IP video.

#### Mechanical:

- Dimensions (W x L x H approx.): 2.5" x 3.8" x 1" (63.5mm x 96.5mm x 25.4mm)

\* sloc is a registered trademark of Intersil Corporation.

## Installation Instructions:

Wiring methods shall be in accordance with the National Electrical Code/NFPA 70/ANSI, and with all local codes and authorities having jurisdiction. Wiring should be UL Listed and/or Recognized wire suitable for the application. eBridge1CR is not intended to be connected to outside plant leads and should be installed indoors within the protected premises. The eBridge1CR is intended for indoor use only.

1. Secure unit to desired mounting surface with a proper fastening device utilizing the unit's mounting hole (Fig. 2a, pg. 3). Unit should be mounted in proximity to ethernet switch/network, NVR or video server.
2. Connect 16VAC/24VAC Class 2 plug-in transformer or 12VDC/24VDC (polarity not observed) Class 2 power supply to jack marked [Power Input] utilizing barrel connector (supplied) (Fig. 1, pg. 2). Use 22AWG-16AWG wire for this connection.
3. Connect structured cable from ethernet switch/NVR (network video server) to RJ45 jack marked [10/100BaseT] (Fig. 2, pg. 3). Connect Coax cable to BNC connector marked [Coax] (Fig. 2, pg. 3).
4. For optional simultaneous Composite Video transmission, attach the Composite Video Cable (Fig. 2, pg. 3) by plugging the two (2) position connector into the Comp. Video input marked on the unit (**Note:** connector is polarized). Connect the BNC side to the composite video input of the NVR, monitor display, matrix switch or other headend equipment.

**Note:** The eBridge is designed to accommodate Megapixel, HD720, HD1080, and VGA (SD) cameras. It is important to note that some high resolution and high frame rate cameras may demand faster headend processing ability, such as a PC graphics card to present a quality image. If the headend processing equipment is insufficient in speed, the image may show pixelation and latency. It is advisable to pretest system if unsure. Alternatively, frame rate and resolution may be reduced to accommodate system equipment.

## Technical Specifications:

Parameter	Description
Connections	BNC for Coax link. RJ45 for ethernet link. Composite video connector for optional composite video service.
Input power requirements	12VDC/275mA, 24VDC/110mA, 16VAC/375mA, 24VAC/200mA.
Indicators	<b>Blue:</b> Coax Link. <b>Yellow (RJ45 connector):</b> On - Link, Off - No Link, Blinking - Activity. <b>Green (RJ45 connector):</b> On - 100Base-TX, Off - 10Base-T. <b>Green:</b> Power.
Environmental Conditions	Operating Ambient Temperature (UL60950-1): 14°F to 122°F (– 10°C to 50°C). Relative humidity: 85%, +/- 5%. Storage Temperature: – 4°F to 158°F (– 20°C to 70°C). Operating Altitude: – 304.8 to 2,000m.
Regulatory Compliance	UL/cUL Listed for Information Technology Equipment (UL 60950-1). CE European Conformity. C-Tick compliant.
Weights (approx.)	Product: 4 oz. (0.11 kg)   Shipping: 7 oz. (0.17 kg)

Fig. 1

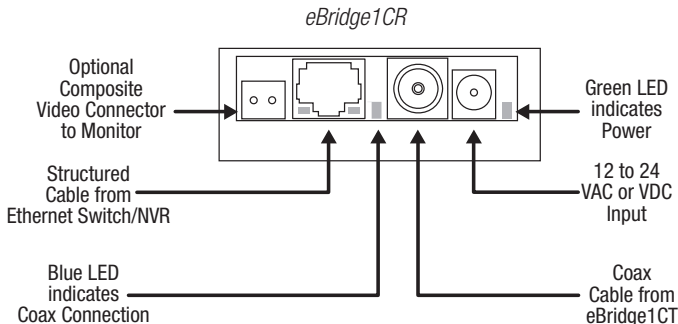

# Single IP Camera Shown With Composite Video Option:

Fig. 2

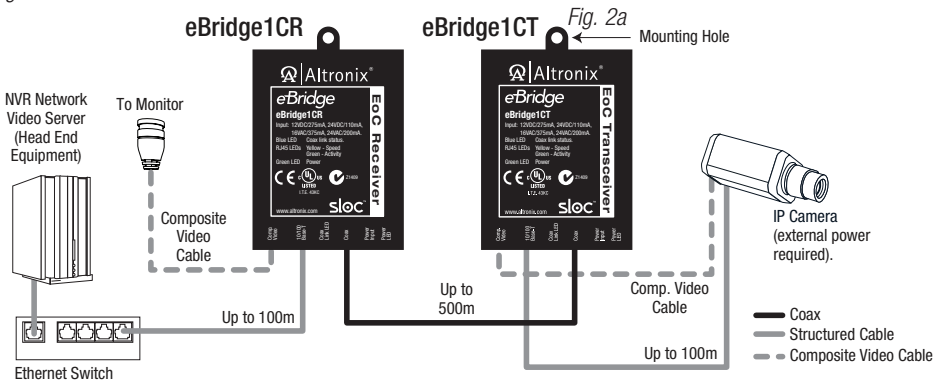
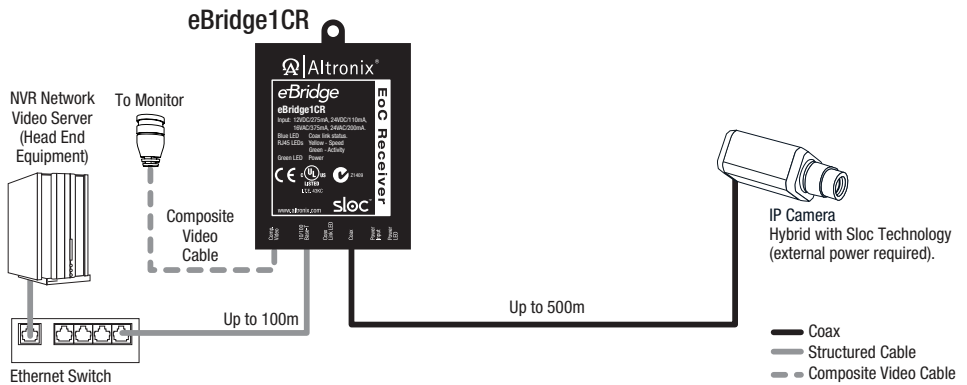

Fig. 3



## Solutions and Installation Notes:

Currently Matrix Switchers, DVRs and NVRs do not readily accommodate multi-picture (Matrix) monitor display capability (typically 4X4 – 16 channel display) for some of the higher resolution cameras. In addition HD cameras use a wide screen format (16:9 aspect ratio). This may not fit as well into the matrix display as the standard screen format (4:3 aspect ratio). In addition high resolution multichannel recording can introduce unacceptable latency in the real-time monitor display.

To achieve high resolution recording along with real-time multi-channel viewing: Record the high resolution IP video via the NVR and the simultaneous composite video via the Matrix switcher to achieve proper display format (Fig. 3, pg. 3).

# Multiple IP Cameras Shown With Composite Video Option:

Fig. 4

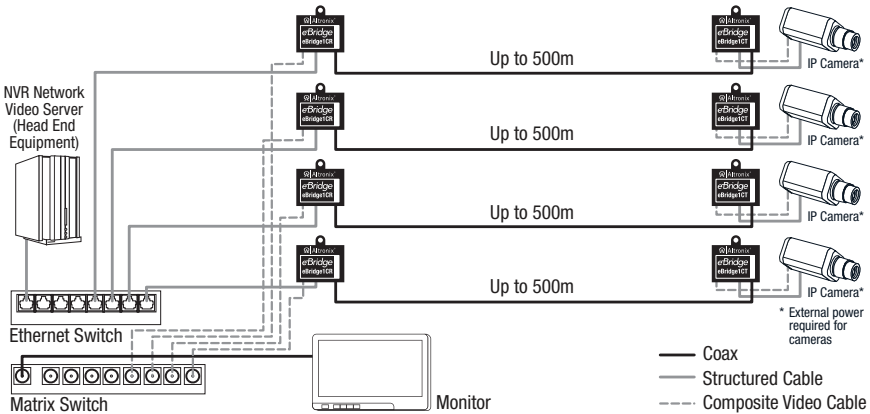

# Multiple IP Cameras Over a Single Coax:

Fig. 4

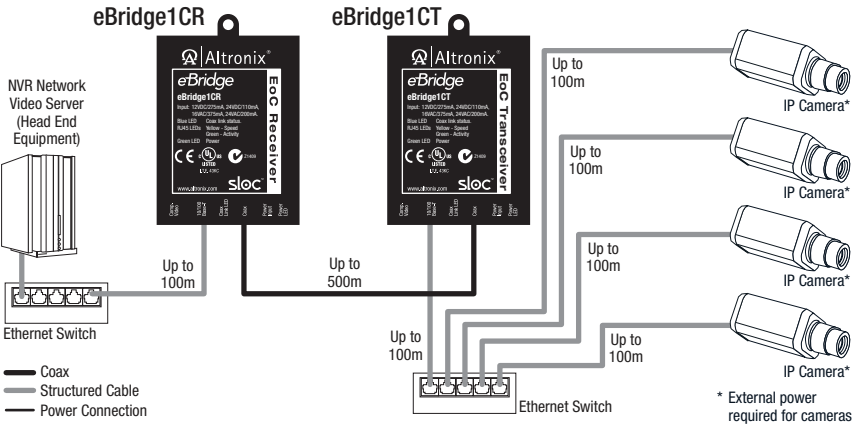

**\*Note:** Multiple cameras require higher bandwidth and headend equipment processing speed. It is advised to test this configuration. eBridge is rated to pass 25Mbps of data at distances up to 500m. With proper headend equipment multiple Megapixel cameras can be used.

Altronix is not responsible for any typographical errors.

140 58th Street, Brooklyn, New York 11220 USA | 718-567-8181 | fax: 718-567-9056  
 website: [www.altronix.com](http://www.altronix.com) | e-mail: [info@altronix.com](mailto:info@altronix.com) | Lifetime Warranty  
 lleBridge1CR Rev. 070612 G12U

