



Video • Data • Power

HubSat4DV Series

Passive UTP Transceiver Hub with
Integral Camera Power

Models Include:

HubSat4DV

- Four (4) Channel Passive UTP Transceiver Hub with Integral Camera Power

HubSat42DV

- Four (4) Channel Passive UTP Transceiver includes
Four (4) HubWayAv Video Balun/Combiners

HubSat43DV

- Four (4) Channel Passive UTP Transceiver includes
Four (4) HubWayDv Video Balun/Combiners

Installation Guide



Rev. 052708



More than just power.™

Installing Company: _____ Service Rep. Name: _____

Address: _____ Phone #: _____

Table of Contents:

Overview	<i>pg. 3</i>
Specifications	<i>pg. 3</i>
Additional Models	<i>pg. 3</i>
Installation Instructions	
HubSat4DV Passive UTP Transceiver Hub with Integral Camera Power	<i>pg. 3</i>
HubSat4DV for Use as a Remote Accessory Module with HubWay/HubWayLD/HubWayLDH UTP Transceiver Hubs	<i>pg. 4</i>
Alternate 24VAC Fixed Camera Hookup	<i>pg. 5</i>
HubSat Circuit Board	<i>pg. 6</i>
HubWayAv, HubWayAv2, HubWayDv, and HubWayDvi Video Balun/Combiners	<i>pg. 7</i>
CAT-5 Structured Cable Wiring Color Codes	<i>pg. 7</i>
Typical Application Drawings	
HubSat4DV Passive UTP Transceiver Hub with Integral Camera Power	<i>pg. 9</i>
HubSat4DV Remote Accessory Module with HubWay UTP Transceiver Hubs	<i>pg. 9</i>
Enclosure Dimensions	<i>pg. 12</i>

Overview:

Altronix HubSat4DV Passive UTP Transceiver Hub with Integral Camera Power transmits UTP video, RS422/RS485 data and power over a single CAT-5 or higher structured cable. Unit provides 4 camera channels in a wall mount enclosure. Video transmission range is up to 750 ft. max. per channel. Units are compatible with AC and/or DC fixed or PTZ cameras when utilizing Altronix HubWayAv or HubWayDv Video Balun/Combiners. In addition, the unit features individually selectable 24VAC or 28VAC PTC protected outputs with surge suppression. Optionally, the HubSat4DV can be used as an accessory module to transmit video from up to 4 cameras over a single CAT-5 or higher structured cable back to the HubWayV, HubWayLDV or HubWayLDHV Passive and Active UTP Transceiver Hubs. In addition, the HubSat4DV provides power to these cameras locally to eliminate the possibility of voltage drop associated with long cable runs.

Specifications:

Input:

- 220VAC, 50/60Hz, 0.5A.
- Primary in-line fuse is rated @ 3.5A/250V.

Video:

- Four (4) channels of quality video over twisted pair up to a distance of 750 ft. per channel.
- Four (4) 75 Ohm video outputs.

Data:

- RS422/RS485 data input.

Power:

- Individually selectable 24VAC or 28VAC power outputs with OFF position.
- Unit provides up to 1A max. per channel not to exceed a total of 4A maximum current.

Power (cont'd):

- PTC protected outputs are rated @ 1A per channel.
- Surge suppression.

Visual Indicators:

- Four (4) power LED indicators.

Enclosure Dimensions (H x W x D approx.):

8.5" x 7.5" x 3.5" (215.9mm x 190.5mm x 88.9mm).

Optional Accessories:

- Video Balun/Combiners:
 - HubWayAv: for use with 24VAC cameras.
 - HubWayAv2: for use with 24VAC cameras.
 - HubWayDv: for use with 12VDC cameras.
 - HubWayDvi: for use with non-isolated 12VDC cameras.

Additional Models:

HubSat42DV

- HubSat4DV with four (4) HubWayAv Video Balun/Combiners for 24VAC Cameras.

HubSat43DV

- HubSat4DV with four (4) HubWayDv Video Balun/Combiners for 12VDC Cameras.

WARNING: To reduce the risk of fire or electric shock do not expose the unit to rain or moisture. This installation should be made by qualified service personnel and should conform to all local codes.

Installation Instructions:

HubSat4DV Passive UTP Transceiver Hub with Integral Camera Power.

1. Mount unit in the desired location. Mark and predrill holes in the wall to line up with the top two keyholes in the enclosure. Install two upper fasteners and screws in the wall with the screw heads protruding. Place the enclosure's upper keyholes over the two upper screws, level and secure. Mark the position of the lower two holes. Remove the enclosure. Drill the lower holes and install two fasteners. Place the enclosure's upper keyholes over the two upper screws. Install the two lower screws and make sure to tighten all screws (*Enclosure Dimensions, pg. 12*). Secure green wire lead to earth ground.
2. Set illuminated master power disconnect circuit breaker to the (OFF) position (*Fig. 4a, pg. 8*).
3. Connect unswitched AC circuit (220VAC, 60Hz) as follows: Green branch wire (ground) connects to the terminal marked \perp , Line connects to the terminal marked [L], and Neutral connects to the terminal marked [N] of the Inlet Appliance Connector (*Fig. 4, pg. 8*). The power LEDs (Green) for Channels 1-4 of the HubSat4DV will illuminate when AC power is present (*Fig. 1e, pg. 6*).
4. Select 24VAC or 28VAC power output for Channels 1-4 with the corresponding voltage adjustment switches (*Fig. 1d, pg. 6*).
5. Connect the BNC video outputs for HubSat4DV Channels 1 - 4 to the corresponding video inputs on the head end equipment (DVR) (*Fig. 1a, pg. 6*).
6. Connect the RS422/RS485 output of the head end equipment (DVR) to the data terminals marked [+ DATA -] of the HubSat4DV unit (polarity must be observed) (*Fig. 1f, pg. 6*).

Note: The Data input terminals of the HubSat4DV must be wired in parallel for proper operation. When using fixed cameras disregard this step.

7. Connect Video Balun/Combiner at camera 1 to the HubSat4DV unit utilizing CAT-5 or higher structured cable. Plug the RJ45 connector at one end of a structured cable into the RJ45 jack marked [PVD1] of the HubSat4DV (Fig. 1i, pg. 6). Plug the RJ45 connector at the opposite end of the structured cable into the RJ45 jack of the Video Balun/Combiner located at camera 1.
 - For 24VAC cameras use Altronix model HubWayAv/HubWayAv2 Video Balun/Combiner (Figs. 2a, 2b, 2e, pg. 7).
 - For 12VDC cameras use Altronix model HubWayDv Video Balun/Combiner (Figs. 2c, 2d, pg. 7).
 - For non-isolated 12VDC cameras use Altronix model HubWayDvi Video Balun/Combiner (Figs. 2c, 2d, pg. 7).

AC LED (Green) of the HubWayAv or DC LED (Red) of the HubWayDv Video Balun/Combiners will illuminate indicating power is present at the cameras (Fig. 2b, 2d, pg. 7).
The total cable distance must not exceed 750 ft. for video transmission between the HubSat4DV and each camera. Repeat this step for each additional camera [PVD2-4].
8. Set illuminated master power disconnect circuit breaker to the RESET (ON) position (Fig. 4a, pg. 8) and measure the output voltage at the power output of each Video Balun/Combiner (Figs. 2b, 2d, pg. 7) before powering each camera to ensure proper operation and avoid possible damage.
 - HubWayAv/HubWayAv2 - Terminals marked [AC POWER] (Figs. 2a, 2b, 2e, pg. 7).
 - HubWayDv/HubWayDvi - Terminals marked [- 12VDC +] (Figs. 2c, 2d, pg. 7).
9. Set illuminated master power disconnect circuit breaker to the (OFF) position (Fig. 4a, pg. 8).
10. Connect the power outputs of the HubWayAv or HubWayDv Video Balun/Combiners to the power inputs of the cameras (Figs. 2a-2e, pg. 7). Polarity must be observed.
11. Connect the terminals marked [+ DATA -] of the HubWayAv or HubWayDv Video Balun/Combiners to the data terminals of the cameras for PTZ control (Figs. 2b-2d, pg. 7). Polarity must be observed. When using fixed cameras disregard this step.
12. Connect the BNC connector of the HubWayAv or HubWayDv Video Balun/Combiners to the BNC video outputs of the cameras (Figs. 2b-2d, pg. 7).
13. Set illuminated master power disconnect circuit breaker to the RESET (ON) position (Fig. 4a, pg. 8).
14. The power LEDs (Green) or Channels 1-4 of the HubSat4DV will illuminate when AC power is present (Fig. 1e, pg. 6). If any of these LEDs are off, a loss of AC power output may be due to a tripped PTC caused by a short circuit or overload condition. If all of the LEDs are OFF there may be a complete loss of supply power to the HubSat4DV unit or the illuminated master power disconnect circuit breaker is in the OFF position or the primary in-line fuse is blown.

To restore the power output for HubSat4DV:

- 1 - Switch corresponding output voltage switch to the OFF position (Fig. 1d, pg. 6).
- 2 - Eliminate the trouble condition.
- 3 - Allow 1 minute for PTC to cool off.
- 4 - Switch output voltage switch to the 24VAC or 28VAC position as desired (Fig. 1d, pg. 6).

HubSat4DV for Use as a Remote Accessory Module with HubWay/HubWayLD/HubWayLDH UTP Transceiver Hubs.

1. Mount unit in desired location.
2. Set illuminated master power disconnect circuit breaker to the (OFF) position (Fig. 4a, pg. 8).
3. Connect 220VAC 50/60Hz to the black and red flying leads of open frame transformer. Secure ground wire (Green) to earth ground (Fig. 4, pg. 8). The power LEDs (Green) for Channels 1-4 of the HubSat4DV will illuminate when AC power is present (Fig. 1e, pg. 6).
4. Select 24VAC or 28VAC power output for Channels 1-4 with the corresponding voltage adjustment switches (Fig. 1d, pg. 6).
5. Video connection between HubSat4DV and HubWayV/HubWayLDV/HubWayLDHV:
Plug the RJ45 connector at one end of a structured cable into the RJ45 jack marked [Video 1 - 4] of the HubSat4DV (Fig. 1g, pg. 6).
Plug the RJ45 connector at the opposite end of the structured cable into the RJ45 jack marked [Channels 1-4, Channels 5-8, Channels 9-12, Channels 13-16] of the HubWayV/HubWayLDV/HubWayLDHV (Fig. 6, pg. 9).
6. Data connection between HubSat4DV and HubWayV/HubWayLDV/HubWayLDHV UTP Transceiver Hubs: Plug the RJ45 connector at one end of a structured cable into the RJ45 jack marked [Data 1-4] of the HubSat4DV (Fig. 1h, pg. 6). Plug the RJ45 connector at the opposite end of the structured cable into the corresponding RJ45 channel jack of the HubWayV/HubWayLDV/HubWayLDHV UTP Transceiver

Hubs (Fig. 6, pg. 9). When using fixed cameras disregard this step.

Example: Using RJ45 jack marked [Video 1-4] of HubSat4DV connected to [Channels 1-4] of the HubWayV/HubWayLDV/HubWayLDHV for video transmission, Using the RJ45 jack marked [Data 1-4] of HubSat4DV connected to the Channel jack marked [4] of the HubWayV/HubWayLDV/HubWayLDHV.

Note: Channels 1-3 can not be used for video transmission when using the RJ45 jack marked [CH 1-4] of the HubWayV/HubWayLDV/HubWayLDHV.

The output voltage switches 1-4 must be set to OFF position (Fig. 6, pg. 9).

7. Connect Video Balun/Combiner at camera 1 to the HubSat4DV unit utilizing CAT-5 or higher structured cable. Plug the RJ45 connector at one end of a structured cable into the RJ45 jack marked [PVD1] of the HubSat4DV (Fig. 1e, pg. 6). Plug the RJ45 connector at the opposite end of the structured cable into the RJ45 jack of the Video Balun/Combiner located at camera 1.
 - For 24VAC cameras use Altronix model HubWayAv/HubWayAv2 Video Balun/Combiner (Figs. 2a, 2b, 2e, pg. 7).
 - For 12VDC cameras use Altronix model HubWayDv Video Balun/Combiner (Fig. 2c, 2d, pg. 7).
 - For non-isolated 12VDC cameras use Altronix model HubWayDvi Video Balun/Combiner (Fig. 2c, 2d, pg. 7).AC LED (Green) of the HubWayAv or DC LED (Red) of the HubWayDv Video Balun/Combiners will illuminate indicating power is present at the cameras (Fig. 2b, 2d, pg. 7). Repeat this step for each additional camera [OUT2-4].

Note: The combined total cable distance for video transmission must not exceed the following distances:

- 750 ft. between the HubWay and each camera routed through the HubSat4DV.
 - 3000 ft. between the HubWayLDV/HubWayLDHV and each camera routed through the HubSat4DV.
8. Set illuminated master power disconnect circuit breaker to the RESET (ON) position (Fig. 4, pg. 8) and measure the output voltage at the power output of each Video Balun/Combiner (Figs. 2b, 2d, pg. 7) before powering each camera to ensure proper operation and avoid possible damage.
 - HubWayAv/HubWayAv2 - Terminals marked [AC POWER] (Figs. 2a, 2b, 2e, pg. 7).
 - HubWayDv/HubWayDvi - Terminals marked [- 12VDC +] (Figs. 2c, 2d, pg. 7).
 9. Set illuminated master power disconnect circuit breaker to the (OFF) position (Fig. 4a, pg. 8).
 10. Connect the power outputs of the HubWayAv or HubWayDv Video Balun/Combiners to the power inputs of the cameras (Figs. 2a-2e, pg. 7). Polarity must be observed.
 11. Connect the terminals marked [+ DATA -] of the HubWayAv or HubWayDv Video Balun/Combiners to the data terminals of the cameras for PTZ control (Figs. 2a-2e, pg. 7). Polarity must be observed. When using fixed cameras disregard this step.
 12. Connect the BNC connector of the HubWayAv or HubWayDv Video Balun/Combiners to the BNC video outputs of the cameras (Figs. 2a-2e, pg. 7).
 13. Set illuminated master power disconnect circuit breaker to the RESET (ON) position (Fig. 4a, pg. 8).
 14. The power LEDs (Green) or Channels 1-4 of the HubSat4DV will illuminate when AC power is present (Fig. 1e, pg. 6). If any of these LEDs are off, a loss of AC power output may be due to a blown fuse or a tripped PTC caused by a short circuit or overload condition. If all of the LEDs are OFF there may be a complete loss of supply power to the HubSat4DV unit or the illuminated master power disconnect circuit breaker is in the OFF position or the primary in-line fuse is blown.

To restore the power output for HubSat4DV:

- 1 - Switch corresponding output voltage switch to the OFF position (Fig. 1d, pg. 6).
- 2 - Eliminate the trouble condition.
- 3 - Allow 1 minute for PTC to cool off.
- 4 - Switch output voltage switch to the 24VAC or 28VAC position as desired (Fig. 1d, pg. 6).

Alternate 24VAC Fixed Camera Hookup (Fig. 6a, pg. 9).

After completing steps 1-5 of Installation Instructions Remote Accessory Module for use with HubWay, HubWayLD or HubWayLDH UTP Transceiver Hubs proceed with the following.

1. Set illuminated master power disconnect circuit breaker to the (OFF) position (Fig. 4a, pg. 8).
2. Connect one end of the coaxial cable to the BNC connector marked [Video1] on HubSat (Fig. 1a, pg. 6). Connect the opposite end of the coaxial cable to the BNC video output of camera 1 (Fig. 6a, pg. 9).
3. Set illuminated master power disconnect circuit breaker to the RESET (ON) position (Fig. 4a, pg. 8). Measure the output voltage at terminal pair marked [AUX1] on HubSat to insure proper operation and avoid possible damage (Fig. 1b, pg. 6).
4. Connect the power output terminal pair marked [AUX1] on HubSat to the power inputs of camera 1 (Fig. 1c, pg. 6). Repeat steps 1-3 for each additional camera [AUX2-4].

Fig. 1 - HubSat4DV Circuit Board

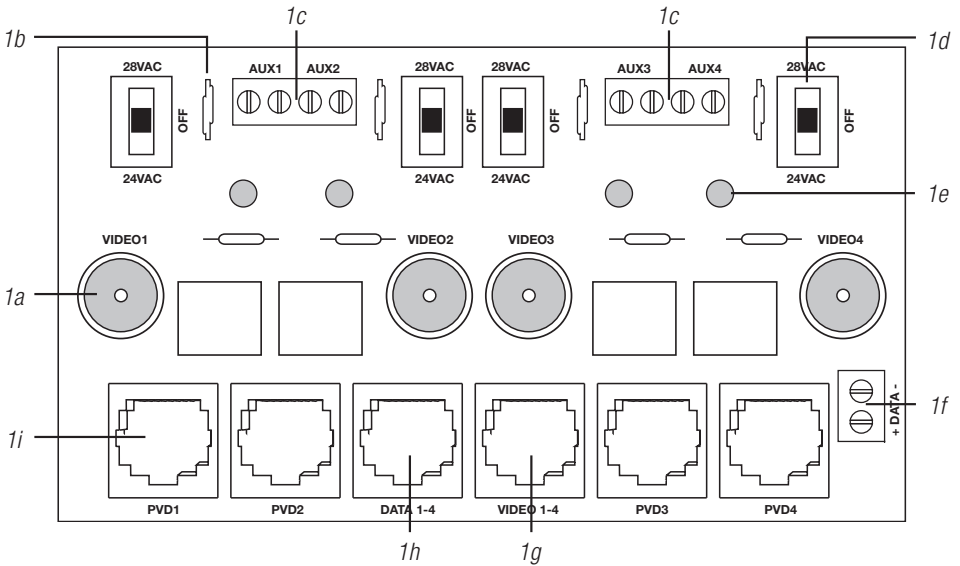

1a - **BNC Connector:** Video in from remote camera video out to DVR.

1b - **Output PTCs:** Protects each output.

1c - **Power Terminals:** 24VAC/28VAC power outputs.

1d - **Output Voltage Switches:** Selects 24VAC/28VAC/OFF for each output.

1e - **LED(s) 1-4:** Power output indicators.

1f - **Data:** RS422/RS485 input from head end equipment (DVR) for PTZ control.

1g - **Channels 1-4:** Single CAT-5 or higher structured cable out to HubWay, HubWayLD or HubWayLDH enables transmission of up to four (4) video signals.

Pin out configuration (Fig. 4, pg. 7).

1h - **Data:** CAT-5 or higher structured cable to data port on HubWay, HubWayLD or HubWayLDH or head end equipment (DVR).

1i - **Channels 1-4:** CAT-5 or higher structured cable to cameras. Pin out configuration (Fig. 3, pg. 7).

HubWayAv, HubWayAv2, HubWayDv, and HubWayDvi Video Balun/Combiners:

Altronix Model Number	Input Voltage from HubWay Unit	Output Voltage to Camera	Camera Type	Power LED
HubWayAv	*24VAC/28VAC	*24VAC/28VAC	*24VAC/28VAC	Green
HubWayAv2	*24VAC/28VAC	*24VAC/28VAC	*24VAC/28VAC	N/A
HubWayDv	*24VAC/28VAC	12VDC	12VDC cameras	Red
HubWayDvi	*24VAC/28VAC	12VDC electronically isolated	12VDC cameras without isolation	Red

*Based on camera load and structured cable length.

Fig. 2

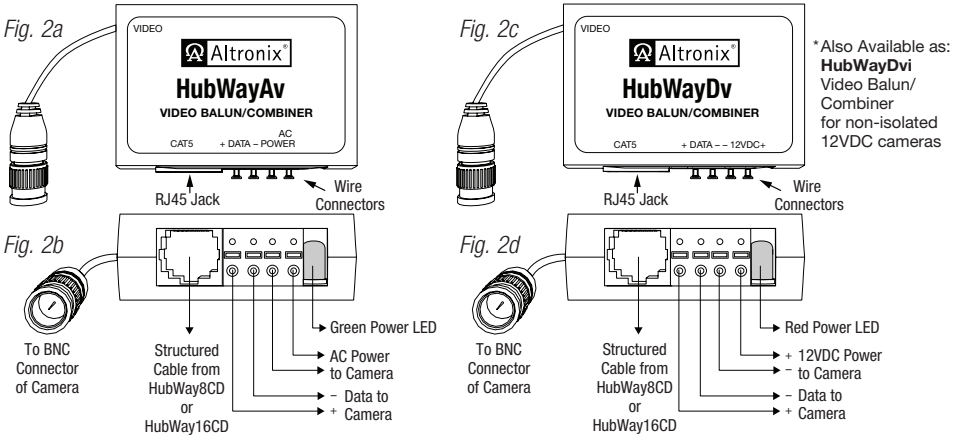
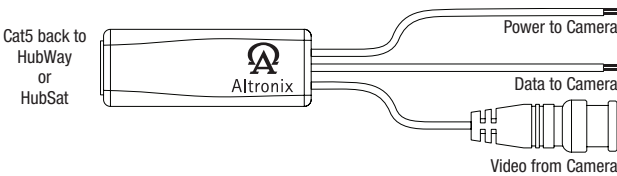

Fig. 2e - HubWayAV2



HubWayAv/HubWayAv2 passes AC voltage from pins 4, 5, 7, 8 to terminals marked [AC Power] (Fig. 3, pg. 7).

HubWayDv/HubWayDvi converts AC voltage to DC voltage from pins 4, 5, 7, 8 to terminals marked [- 12VDC +] (Fig. 3, pg. 7).

Fig. 3 - CAT-5 Structured Cable Wiring Color Codes and PIN Configurations PVD1-4 on HubSat4DV and Video Balun/Combiner

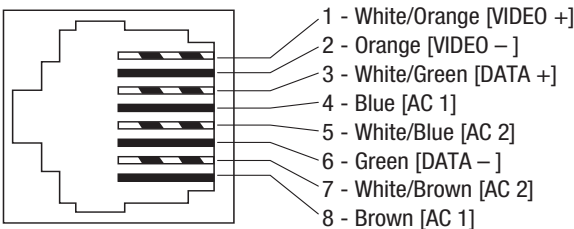
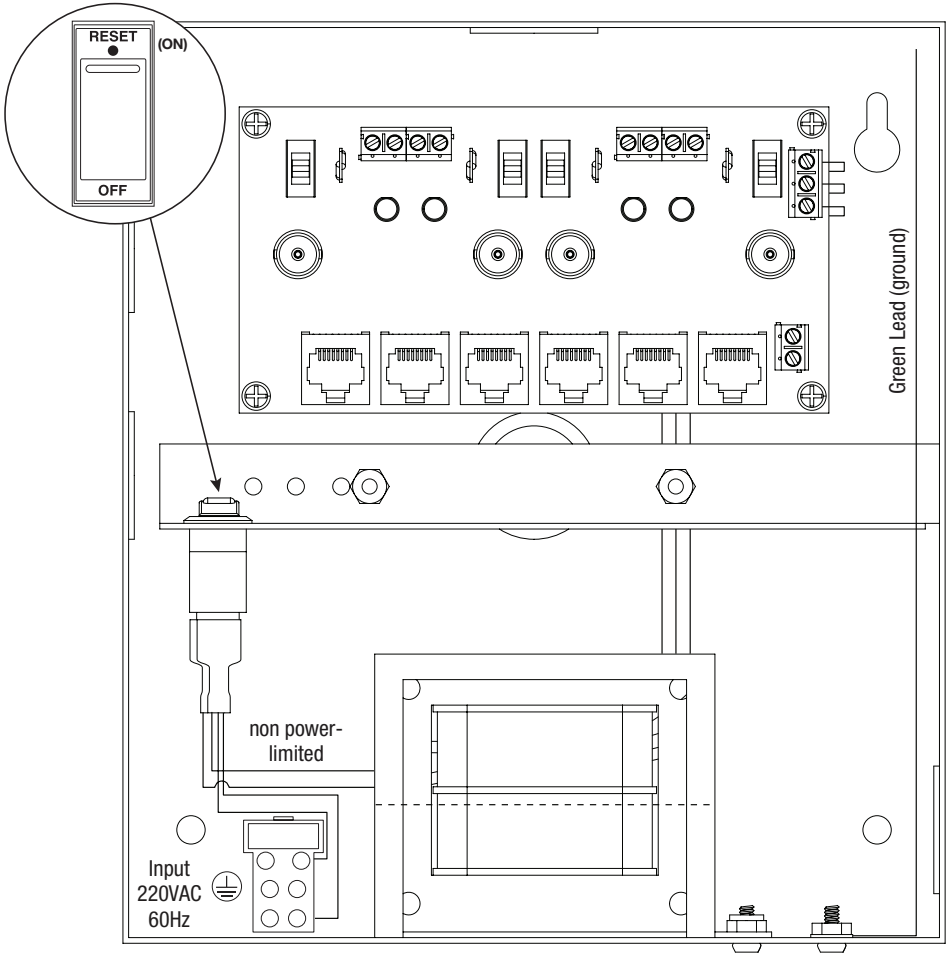

Fig. 4

- Fig. 4a - Illuminated master power disconnect circuit breaker:
- OFF position: circuit breaker tripped – Switch not illuminated.
 - RESET (ON) position – Switch illuminated.



Typical Application Drawing

HubSat4DV Passive UTP Transceiver Hub with Integral Camera Power:

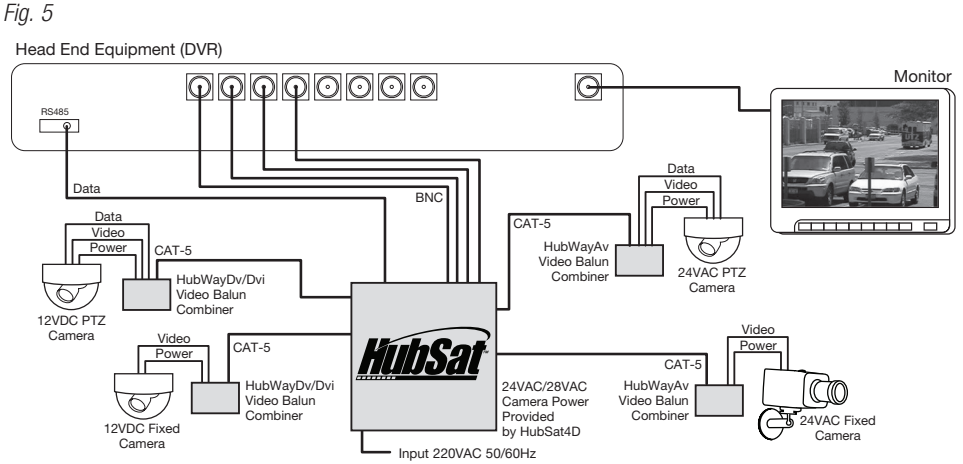

Typical Application Drawing

HubSat4DV Remote Accessory Module with HubWay UTP Transceiver Hubs:

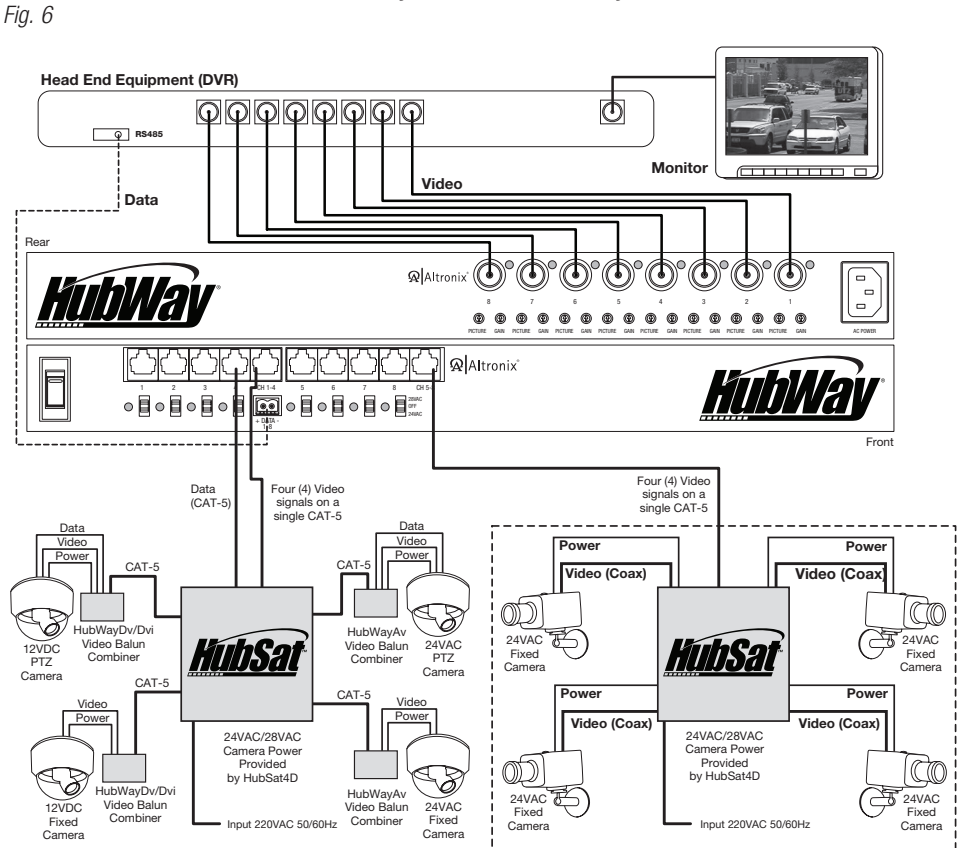

Fig. 6a - Alternate 24VAC fixed camera hookup.

Notes:

Notes:



The lightning flash with arrowhead symbol within an equilateral triangle is intended to alert the user to the presence of an insulated DANGEROUS VOLTAGE within the product's enclosure that may be of sufficient magnitude to constitute an electric shock.



The exclamation point within an equilateral triangle is intended to alert the user to the presence of important operating and maintenance (servicing) instructions in the literature accompanying the appliance.



CAUTION
RISK OF ELECTRIC SHOCK
DO NOT OPEN



CAUTION: To reduce the risk of electric shock do not open enclosure. There are no user serviceable parts inside. Refer servicing to qualified service personnel.

Enclosure Dimensions (H x W x D approximate):

8.5" x 7.5" x 3.5" (215.9mm x 190.5mm x 88.9mm)

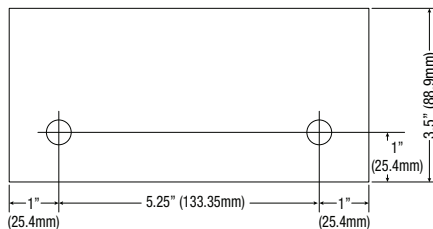
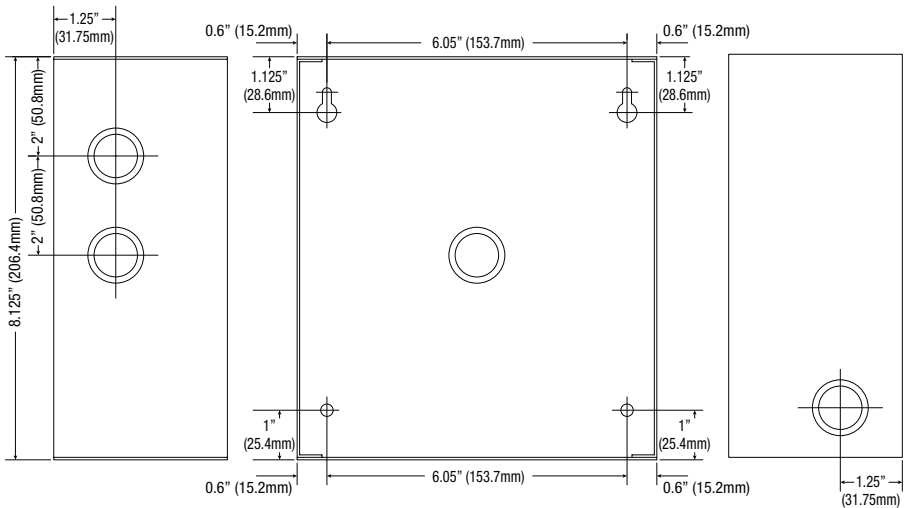
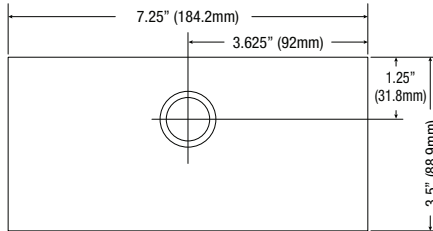

Altronix is not responsible for any typographical errors.

140 58th Street, Brooklyn, New York 11220 USA | phone: 718-567-8181 | fax: 718-567-9056
website: www.altronix.com | e-mail: info@altronix.com | Lifetime Warranty
III-HubSat4DV K18U

