



Video • Data • Power

HubWayLDi Series

Active UTP Transceiver Hubs
with Integral Isolated Camera Power

Models Include:

HubWayLD8Di

- UL Listed eight (8) Channel Active UTP Transceiver Hub with Integral Isolated Camera Power

HubWayLD82Di

- UL Listed eight (8) Channel Active UTP Transceiver Hub with Integral Isolated Camera Power
- Includes eight (8) UL Listed Accessory HubWayAv Video Balun/Combiners

HubWayLD83Di

- UL Listed eight (8) Channel Active UTP Transceiver Hub with Integral Isolated Camera Power
- Includes eight (8) UL Listed Accessory HubWayDv Video Balun/Combiners

HubWayLD16Di

- UL Listed sixteen (16) Channel Active UTP Transceiver Hub with Integral Isolated Camera Power

HubWayLD162Di

- UL Listed sixteen (16) Channel Active UTP Transceiver Hub with Integral Isolated Camera Power
- Includes sixteen (16) UL Listed Accessory HubWayAv Video Balun/Combiners

HubWayLD163Di

- UL Listed sixteen (16) Channel Active UTP Transceiver Hub with Integral Isolated Camera Power
- Includes sixteen (16) UL Listed Accessory HubWayDv Video Balun/Combiners

Installation Guide



Rev. 030408

More than just power.™

Installing Company: _____ Service Rep. Name: _____

Address: _____ Phone #: _____

Overview:

Altronix HubWayLD8Di/16Di Active UTP Transceiver Hub with Integral Isolated Camera Power transmits UTP video, RS422/RS485 data and power over a single CAT-5 or higher structured cable. Unit provides 8 or 16 camera channels in a space saving 1U EIA 19" rack mount chassis which may be rack, wall or shelf mounted. Video transmission range is up to 3000 ft. max. per channel. Units are compatible with AC and/or DC fixed or PTZ cameras when utilizing Altronix HubWayAv, HubWayAv2, HubWayDv or HubWayDvi Video Balun/Combiners. In addition, the unit features individually selectable 24VAC or 28VAC PTC protected outputs with surge suppression. An optional HubSat4D Passive UTP Transceiver Hub with Integral Camera Power can be used as an accessory module to transmit video from up to 4 cameras over a single CAT-5 or higher structured cable back to the HubWayLD8Di/16Di. In addition, the HubSat4D provides power to these cameras locally to eliminate the possibility of voltage drop associated with long cable runs.

HubWayLDi Specifications:

HubWayLD8Di/LD82Di/LD83Di

Input:

- 115VAC 60Hz, 2.5A or 230VAC 50/60Hz, 1.5A.

Video:

- Eight (8) channels of video over twisted pair up to a distance of 3000 ft. per channel.
- Eight (8) 75 ohm video outputs.

Power:

- Unit provides up to 1A max. per channel not to exceed a total of 8A (150VA) maximum current.

HubWayLD16Di/LD162Di/LD163Di

Input:

- 115VAC 60Hz, 5A or 230VAC 50/60Hz, 2.5A.

Video:

- Sixteen (16) channels of video over twisted pair up to a distance of 3000 ft. per channel.
- Sixteen (16) 75 ohm video outputs.

Power:

- Unit provides up to 1A max. per channel not to exceed a total of 16A (300VA) maximum current.

Common Specifications:

Agency Listings:

- UL Listed for Commercial CCTV Equipment (UL 2044).
- CUL Listed - CSA Standard C22.2 No.1-04, Audio, Video and Similar Equipment.

Data:

- RS422/RS485 data inputs.

Power:

- Individually selectable 24VAC or 28VAC power outputs with OFF position.
- Individual electronically isolated PTC outputs.
- PTCs are rated @ 1A per channel.
- Surge suppression.

Visual Indicators:

- AC input power indicator.
- Video signal and power LED indicators.

Features:

- Picture and Gain control.
- Illuminated master power disconnect circuit breaker with manual reset.
- IEC 320 - 3-wire grounded line cord (detachable).
- Unit can be rack, wall or shelf mounted.
- 1U rack mount chassis for standard EIA 19" rack.

Accessories:

- Video Balun/Combiners:
 - HubWayAv: for use with 24VAC cameras.
 - HubWayAv2: for use with 24VAC cameras.
 - HubWayDv: for use with 12VDC cameras.
 - HubWayDvi: for use with non-isolated 12VDC cameras.
- Optional HubSat4D allows transmission of up to four (4) video signals over a single CAT-5 or higher structured cable.

Additional Models:

HubWayLD82Di

- HubWayLD8Di with eight (8) UL Listed Accessory HubWayAv Video Balun/Combiners for 24VAC Cameras.

HubWayLD83Di

- HubWayLD8Di with eight (8) UL Listed Accessory HubWayDv Video Balun/Combiners for 12VDC Cameras.

HubWayLD162Di

- HubWayLD16Di with sixteen (16) UL Listed Accessory HubWayAv Video Balun/Combiners for 24VAC Cameras.

HubWayLD163Di

- HubWayLD16Di with sixteen (16) UL Listed Accessory HubWayDv Video Balun/Combiners for 12VDC Cameras.

WARNING: To reduce the risk of fire or electric shock do not expose the unit to rain or moisture. This installation should be made by qualified service personnel and should conform to all local codes.

Installation Instructions:

1. Set the input voltage selector switch located on the left side of the HubWayLD8Di/LD16Di unit (facing front panel) for 115VAC or 230VAC operation (Fig. 1k, pg. 4).
2. Attach mounting brackets to HubWayLDi unit for rack or wall mount installation (Fig. 6-7, pg. 8). Affix rubber pads to HubWayLDi for shelf installation (Fig. 8, pg. 8).
3. Secure the unit in a rack, mount unit to a wall or place unit on a shelf as desired (unit should be spaced at least 3" from any video monitors).
4. Set illuminated master power disconnect circuit breaker to the (OFF) position (Fig. 5, pg. 7).
5. Plug the grounded AC line cord (included) into the IEC 320 connector of the HubWayLD8Di/HubWayLD16Di unit (Fig. 1j, pg. 4). Insert the plug end of the line cord into a grounded AC receptacle.
6. Set voltage output selector switch of each camera channel for 24VAC or 28VAC (Fig. 1d, pg. 4).
7. Connect the BNC video outputs for HubWayLD8Di/LD16Di Channels 1 - 8 (Channels 1-16) to the corresponding video inputs on the head end equipment (DVR) (Fig. 1f, pg. 4).
8. Connect the RS422/RS485 output of the head end equipment (DVR) to the one (1) or both data input terminal blocks of the HubWayLD8Di or HubWayLD16Di unit (polarity must be observed) (Fig. 1e, pg. 4).
Note: The Data input terminals of the HubWayLD8Di or HubWayLD16Di must be wired in parallel for proper operation. When using fixed cameras disregard this step.
9. Connect Video Balun/Combiner at camera 1 to the HubWayLD8Di or HubWayLD16Di unit utilizing CAT-5 or higher structured cable. Plug the RJ45 connector at one end of the structured cable into the RJ45 jack marked [Channel 1] of the HubWayLD8Di/LD16Di (Fig. 1a, pg. 4). Plug the RJ45 connector at the opposite end of the structured cable into the RJ45 jack of the Video Balun/Combiner located at camera 1.
 - For 24VAC cameras use Altronix model HubWayAv/HubWayAv2 Video Balun/Combiner (Fig. 2a, 2b, 2e, pg. 5).
 - For 12VDC cameras use Altronix model HubWayDv Video Balun/Combiner (Fig. 2c, 2d, pg. 5).
 - For non-isolated 12VDC cameras use Altronix model HubWayDvi Video Balun/Combiner (Fig. 2c, 2d, pg. 5).Repeat steps 6-9 for each additional camera (Channels 2-8 or Channels 2-16).
Note: When a particular camera exceeds the maximum distance for power transmission, a local external power source is required. Optionally, an Altronix HubSat4D Passive UTP Transceiver Hub with Integral Camera Power may be utilized (Fig. 4a, pg. 6).
The combined total cable distance must not exceed 3000 ft. for video transmission between the HubWayLD8Di/LD16Di and each camera routed through the HubSat4D.
10. Set illuminated master power disconnect circuit breaker to the RESET (ON) position (Fig. 5, pg. 7) and measure the output voltage at the power output of each Video Balun/Combiner (Fig. 2b, 2d, pg. 5) before powering each camera to ensure proper operation and avoid possible damage.
 - HubWayAv/HubWayAv2 - Terminals marked [AC POWER] (Fig. 2a, 2b, 2e, pg. 5).
 - HubWayDv/HubWayDvi - Terminals marked [- 12VDC +] (Fig. 2c, 2d, pg. 5).
11. Set illuminated master power disconnect circuit breaker to the (OFF) position to make the final connections (Fig. 5, pg. 7).
12. Connect the power outputs of the HubWayAv, HubWayAv2, HubWayDv or HubWayDvi Video Balun/Combiners to the power inputs of the cameras (Fig. 2a-2e, pg. 5). Polarity must be observed.
13. Connect the terminals marked [+ DATA -] of the HubWayAv or HubWayDv Video Balun/Combiners to the data terminals of the cameras for PTZ control (Fig. 2a-2e, pg. 5). Polarity must be observed.
When using fixed cameras disregard this step.
14. Connect the BNC connector of the HubWayAv, HubWayAv2, HubWayDv or HubWayDvi Video Balun/Combiners to the BNC video outputs of the cameras (Fig. 2a-2e, pg. 5).
15. Upon completion of wiring set illuminated master power disconnect circuit breaker to the RESET (ON) position (Fig. 5, pg. 7).
16. The power LEDs (Red) located on the front of the HubWayLD8Di/LD16Di will illuminate when AC power is present (Fig. 1c, pg. 4).
Note: If any of these LEDs are not illuminated, either a voltage output selector switch is in the OFF position or the PTC is tripped for that channel.
To reset the PTC:
 1. Set the voltage output selector switch for that corresponding channel to the OFF position.
Switch must remain in the OFF position for approximately 2 minutes in order for the PTC to reset.
 2. Eliminate the trouble condition (short circuit or overload).
 3. Set the voltage output selector switch for 24VAC or 28VAC (Fig. 1d, pg. 4).
17. AC LED (Green) of the HubWayAv or DC LED (Red) of the HubWayDv/HubWayDvi Video Balun/Combiners will illuminate indicating power is present at the cameras (Fig. 2b, 2d, pg. 5).
18. The video signal indicator LEDs (Red) located on the rear of the HubWayLD8Di /LD16Di will illuminate when video signal is present (Fig. 1i, pg. 4). If any of these LEDs are not illuminated, no video signal is present for that corresponding channel.
19. Optimize the picture quality for Channels 1-8 (Channels 1-16) by adjusting the corresponding potentiometers marked [Picture] (Fig. 1g, pg. 4).
20. Set gain for Channels 1-8 or Channels 1-16 by adjusting the corresponding potentiometers marked [Gain].

Fig. 1

1e - Data:

Removable terminal blocks for RS422/RS485 input from head end equipment (DVR) for PTZ control.

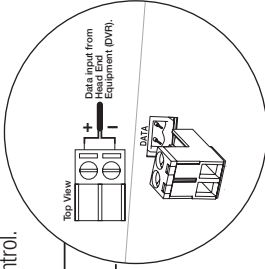

1b - Channels 1-4, Channels 5-8, Channels 9-12 & Channels 13-16: CAT-5 or higher structured cable from optional HubSat4D enables video transmission from up to four (4) cameras.

1a - Channels 1-8 (HubWayLD8i) or Channels 1-16 (HubWayLD16i): CAT-5 or higher structured cable to Video/Balun Combiners at cameras 1-8 or 1-16. When using an optional HubSat4D any of the outputs can be utilized for the data transmission to PTZs.

1c - LED(s) 1-16: Power indicators.

1d - Output voltage switches: Selects 24VAC/28VAC/OFF for each output.

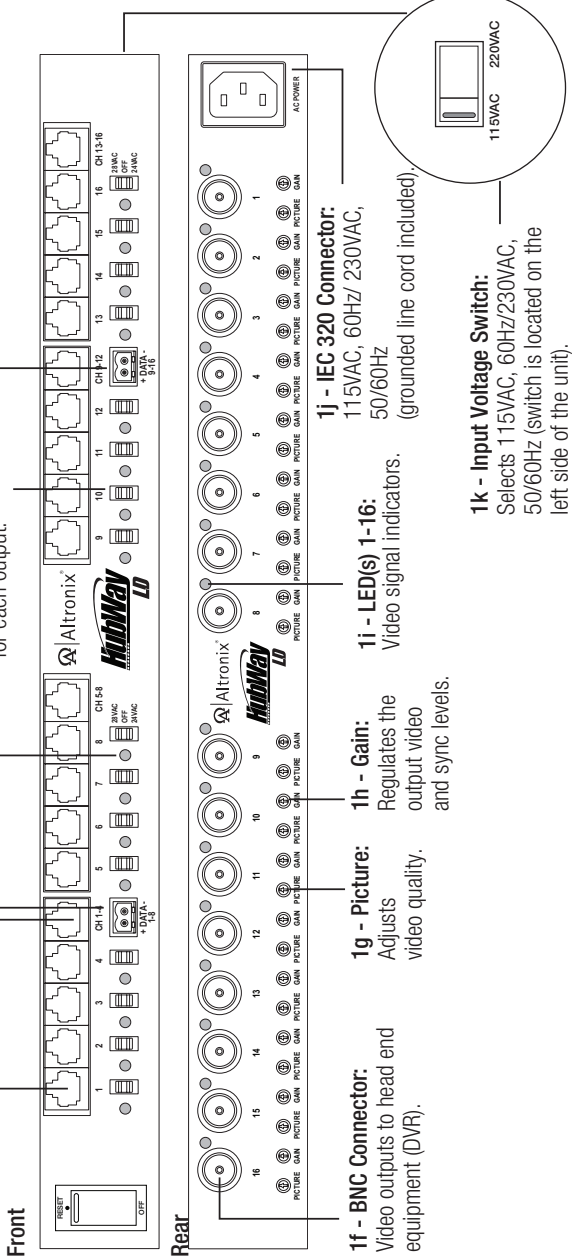

1j - IEC 320 Connector: 115VAC, 60Hz/ 230VAC, 50/60Hz (grounded line cord included).

1i - LED(s) 1-16: Video signal indicators.

1h - Gain: Regulates the output video and sync levels.

1g - Picture: Adjusts video quality.

1f - BNC Connector: Video outputs to head end equipment (DVR).

1k - Input Voltage Switch: Selects 115VAC, 60Hz/230VAC, 50/60Hz (switch is located on the left side of the unit).

HubWayAv, HubWayAv2, HubWayDv, and HubWayDvi Video Balun/Combiners:

Altronix Model Number	Input Voltage from HubWay Unit	Output Voltage to Camera	Camera Type	Power LED
HubWayAv	*24VAC/28VAC	*24VAC/28VAC	*24VAC/28VAC	Green
HubWayAv2	*24VAC/28VAC	*24VAC/28VAC	*24VAC/28VAC	N/A
HubWayDv	*24VAC/28VAC	12VDC	12VDC cameras	Red

*Based on camera load and structured cable length.

Fig. 2

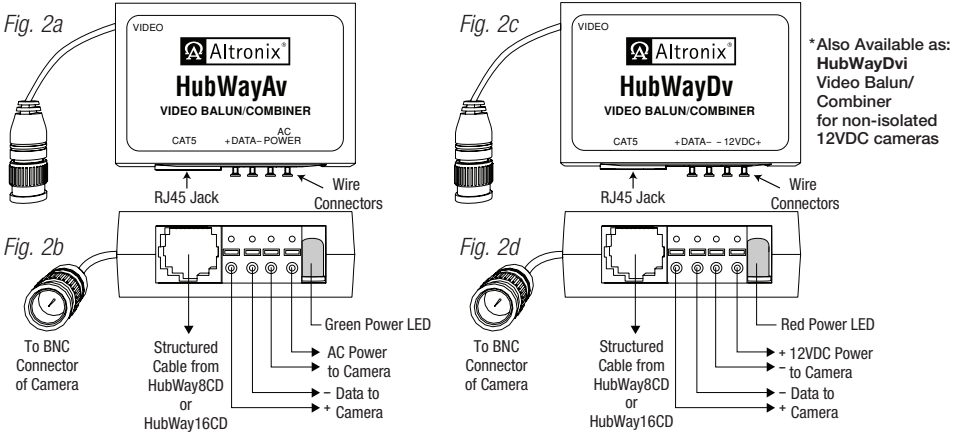
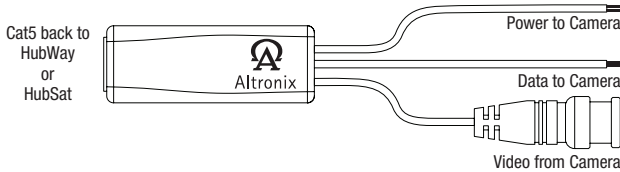

Fig. 2e - HubWayAV2



HubWayAv/HubWayAv2 passes AC voltage from pins 4, 5, 7, 8 to terminals marked [AC Power] (Fig. 3, pg. 5).

HubWayDv/HubWayDvi converts AC voltage to DC voltage from pins 4, 5, 7, 8 to terminals marked [- 12VDC +] (Fig. 3, pg. 5).

Fig. 3 - CAT-5 Structured Cable Wiring Color Codes and PIN Configurations

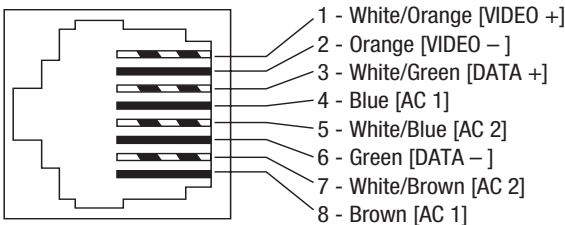

Typical Applications:

Fig. 4

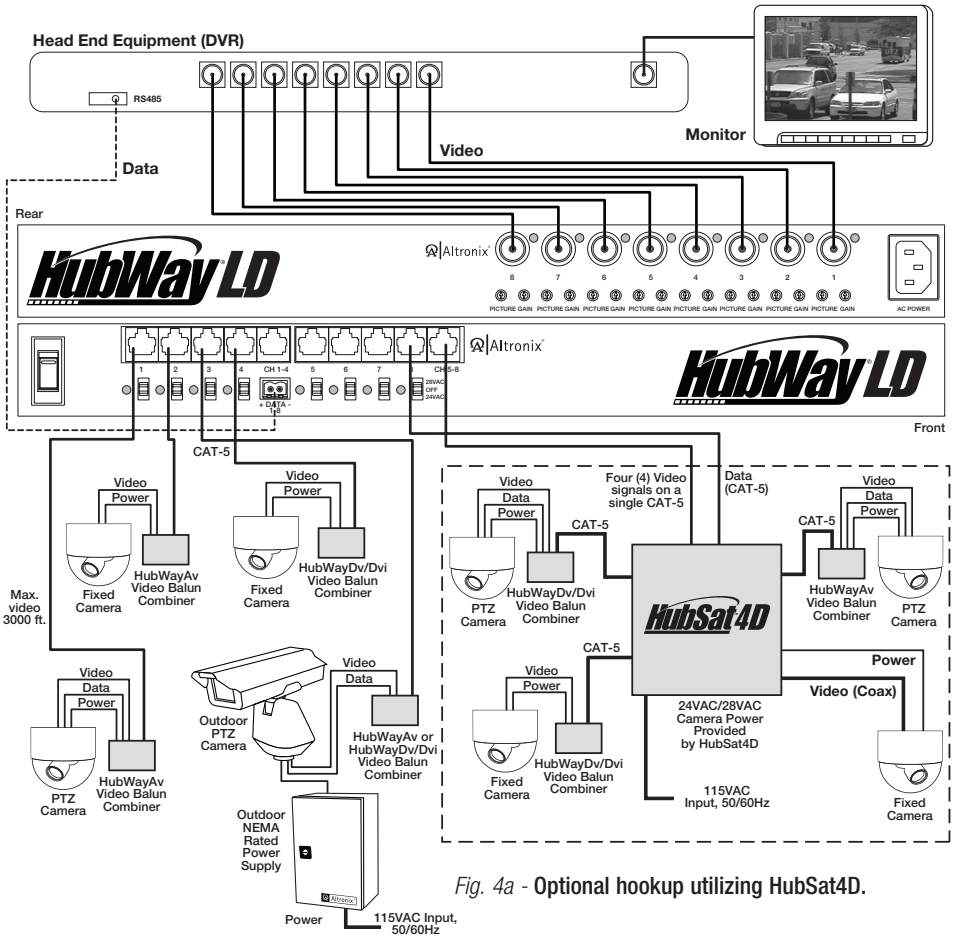

Fig. 4a - Optional hookup utilizing HubSat4D.



The lightning flash with arrowhead symbol within an equilateral triangle is intended to alert the user to the presence of an insulated DANGEROUS VOLTAGE within the product's enclosure that may be of sufficient magnitude to constitute an electric shock.



The exclamation point within an equilateral triangle is intended to alert the user to the presence of important operating and maintenance (servicing) instructions in the literature accompanying the appliance.



CAUTION
RISK OF ELECTRIC SHOCK
DO NOT OPEN



CAUTION: To reduce the risk of electric shock do not open enclosure. There are no user serviceable parts inside. Refer servicing to qualified service personnel.

1U EIA 19" Rack Mount Chassis Dimensions (H x W x D approximate):

1.625" x 19.125" x 8.5" (41.3mm x 486mm x 216mm)

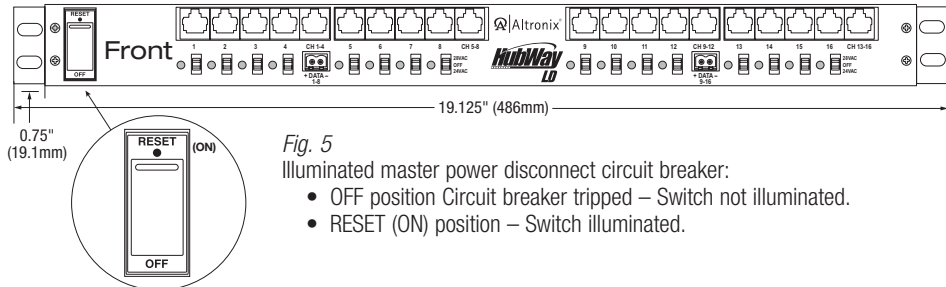
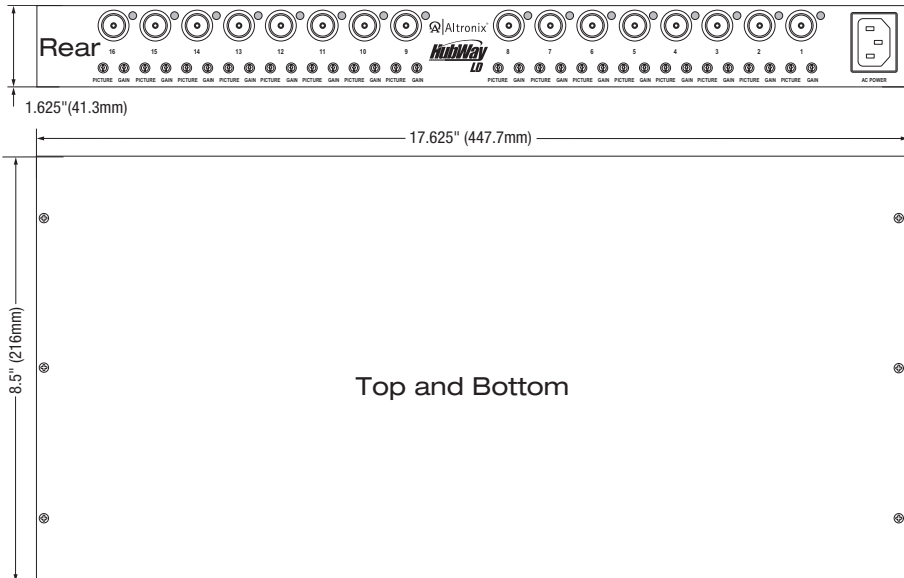

Fig. 5

Illuminated master power disconnect circuit breaker:

- OFF position Circuit breaker tripped – Switch not illuminated.
- RESET (ON) position – Switch illuminated.

Mounting Options:

Rack Mount Installation

1. Remove factory installed screws from both sides of the rack chassis (Fig. 6a).
2. Install mounting brackets (A) on the left and right side of rack chassis using the two (2) flat head screws (B) (included) (Fig. 6b).
3. Place unit into desired EIA 19" rack position and secure with mounting screws (not included) (Fig. 6c).

Fig. 6

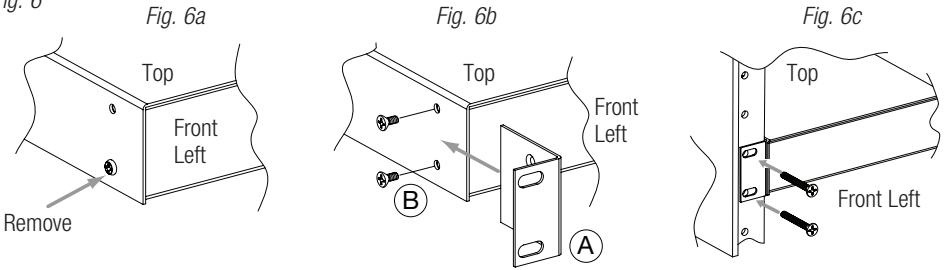

Wall Mount Installation

1. Install mounting brackets (A) on the left and right side of rack chassis using two (2) flat head screws (B) (included) (Fig. 7a).
 2. Place unit at desired location and secure with mounting screws (not included) (Fig. 7b).
- Caution:** It is necessary to make sure mounting screws are securely fastened to a beam when installing.

Fig. 7

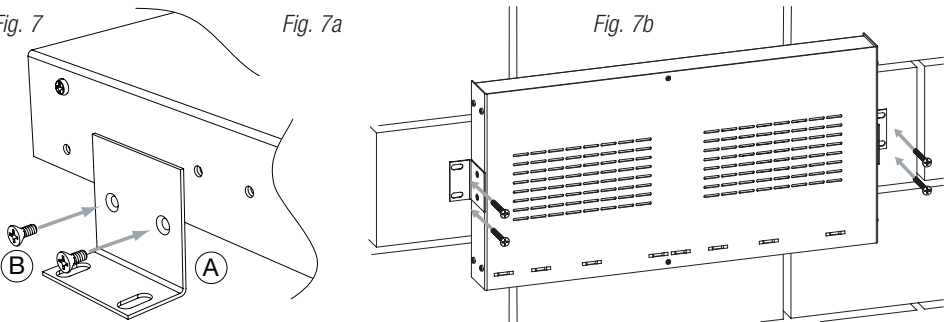

Shelf Installation

1. Position and affix rubber pads (C) (included) at each corner on the bottom of the unit (Fig. 8).
2. Place unit in desired location.

Fig. 8

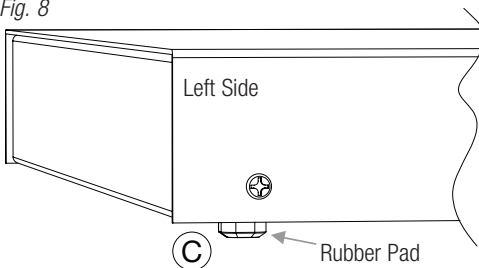

Mounting Hardware (Included):

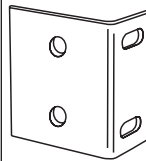

(A) Two (2) mounting brackets



(B) Six (6) flat head screws for mounting brackets.



(C) Four (4) rubber pads.

Altronix is not responsible for any typographical errors.

140 58th Street, Brooklyn, New York 11220 USA | phone: 718-567-8181 | fax: 718-567-9056
website: www.altronix.com | e-mail: info@altronix.com | Lifetime Warranty
IH-HubWayLD8Di/HubWayLD16Di K22U



MEMBER