



# ***M220 Series Multi-Output Access Control Power Supply Chargers***

## ***Installation Guide***

### ***Models Include:***

- ***AL300M220***
  - 2.5 amp @ 12VDC or 24VDC.
- ***AL600M220***
  - 6 amp @ 12VDC or 24VDC.
- ***AL1024M220***
  - 10 amp @ 24VDC.
- ***AL400M220***
  - 4 amp @ 12VDC or 3 amp @ 24VDC.
- ***AL1012M220***
  - 10 amp @ 12VDC.

***For a red enclosure, add an "R" suffix to the part # e.g. AL300MR220***

### Overview:

M220 Series multi-output access control power supply/chargers are specifically designed for use with access control systems and accessories. These units convert a 220VAC 50/60Hz input into five (5) individually protected 12VDC or 24VDC outputs (see specifications). Each output will route power to a variety of access control hardware devices including Mag Locks, Electric Strikes, Magnetic Door Holders, etc. These outputs will operate in both Fail-Safe and Fail-Secure modes. Controlled trigger input is achieved through normally open [NO] or normally closed [NC] supervised input or the polarity reversal from an FACP (Fire Alarm Control Panel). A form “C” dry output relay enables HVAC Shutdown, Elevator Recall or may be used to trigger auxiliary devices.

### M220 Series Power Supply Configuration Reference Chart:

Altronix Model Number	12VDC Total Output Current (amp)	24VDC Total Output Current (amp)	Outputs	220VAC 50/60Hz Input (current draw/amp)	Power Supply Board Input Fuse Rating
AL300M220	2.5	2.5	5	0.8 amp	3.5 amp/250VAC
AL400M220	4	3	5	0.95 amp	3.5 amp/250VAC
AL600M220	6	6	5	1.25 amp	3.5 amp/250VAC
AL1024M220	—	10	5	2.2 amp	3.5 amp/250VAC
AL1012M220	10	—	5	1.0 amp	3.5 amp/250VAC

### Specifications:

#### Input:

- Power input 220VAC 50/60Hz (see reference chart above).
- Fire Alarm Panel or Access Control System trigger inputs. [NO] or [NC] supervised trigger input and polarity reversal trigger input (4mA draw from FACP).

#### Output:

- Five (5) individual power outputs.
- Current limit is 2 amp @ 12VDC or 24VDC per output (12VDC only for AL1012M220 and 24VDC only for AL1024M220).
- Filtered and electronically regulated outputs.
- Thermal and short circuit protection with auto reset.
- Overload protection.
- Output relay energizes when unit is triggered (form “C” contact rated 1 amp @ 28VDC).

#### Battery Backup:

- Built-in charger for sealed lead acid or gel type batteries.
- Automatic switch over to stand-by battery when AC fails.
- AL300XB220, AL400XB220, AL600XB220 and AL1012XB220 (Power Supply Board) maximum charge current 0.7 amp.
- AL1024XB220 (Power Supply Board) maximum charge current 3.6 amp.

#### Battery Backup (cont'd):

- Zero voltage drop when switching over to battery backup.
- AL300M220, AL400M220 and AL600M220 enclosures accommodate up to two (2) 12VDC/7AH batteries.
- AL1012M220 should be fitted with one (1) 12VDC/12AH battery.
- AL1024M220 enclosure accommodates up to two (2) 12VDC/12AH batteries.

#### Visual Indicators:

- DC output LED indicator.
- LEDs indicate condition of power outputs.
- Power & input trigger LED's.

#### Supervision:

- AC fail supervision (form “C” contact).
- Low battery supervision (form “C” contact).
- Battery presence supervision (form “C” contact).
- Power fail supervision relay (form “C” contact rated 1 amp @ 28VDC).
- Power supply is complete with enclosure, cam lock, transformer and battery leads.

## Installation Instructions:

Wiring methods should be in accordance with the National Electrical Code/NFPA 70/NFPA 72/ANSI, and with all local codes and authorities having jurisdiction. Product is intended for indoor use only.

1. Mount unit in the desired location. Mark and predrill holes in the wall to line up with the top two keyholes in the enclosure. Install two upper fasteners and screws in the wall with the screw heads protruding. Place the enclosure's upper keyholes over the two upper screws; level and secure. Mark the position of the lower two holes. Remove the enclosure. Drill the lower holes and install three fasteners. Place the enclosure's upper keyholes over the two upper screws. Install two lower screws and make sure to tighten all screws (*Enclosure Dimensions, pg. 13,14*). Secure enclosure to earth ground. It is recommended to first review the following tables for screw terminals, switch selection and LED status indications. This will greatly facilitate installation hook-up.

### Carefully review:

<b>Output Voltage &amp; Stand-by Specifications</b>	(pg. 4)	<b>Terminal Identification Table</b>	(pg. 10)
<b>LED Diagnostics</b>	(pg. 9)	<b>Typical Application Diagrams</b>	(pgs. 11 & 12)

2. **Set output voltage:**

AL300M220, AL400M220 and AL600M220 - set desired DC output voltage by setting switch SW1 to the appropriate position on the power supply board (*Fig. 1b, pg. 5; Fig. 2b, pg. 6*). AL1012M220 is 12VDC only and AL1024M220 is 24VDC only. (**Output Voltage and Stand-by Specification Charts below, pg. 4**).

3. Secure green lead to earth ground. Connect AC power (220VAC 50/60Hz) to the terminals marked [L, N] on power supply board (*Fig. 1, pg. 5; Fig. 2, pg. 6; Fig. 3, pg. 7; Fig. 4, pg. 8*).

Use 18 AWG or larger for all power connections (Battery, DC output, AC input).

Use 22 AWG to 18 AWG for power-limited circuits (AC Fail/Low Battery reporting).

4. Measure output voltage before connecting devices. This helps avoiding potential damage.

**Keep power-limited wiring separate from non power-limited wiring (220VAC 50/60Hz Input, Battery Wires).**

**Minimum 0.25" spacing must be provided.**

**CAUTION: Do not touch exposed metal parts. Shut branch circuit power before installing or servicing equipment. There are no user serviceable parts inside. Refer installation and servicing to qualified service personnel.**

5. Connect Fail-Secure type locking hardware (e.g. door strikes and electronic dead bolts) positive leads to the terminals marked [1 through 5 POS (+) DC OUTPUT (ALARM)] on MOM5 board and the negative leads to terminals marked [NEG 1 through NEG 5] on MOM5 board (*Fig. 1, pg. 5; Fig. 2, pg. 6; Fig. 3, pg. 7; Fig. 4, pg. 8*).
6. Connect Fail-Safe type locking hardware (e.g. mag locks, door strikes and door holders) positive leads to the terminals marked [6 through 10 POS (+) DC OUTPUT (STAND-BY)] on MOM5 board and negative leads to the terminals marked [NEG 1 through NEG 5] on MOM5 board (*Fig. 1, pg. 5; Fig. 2, pg. 6; Fig. 3, pg. 7; Fig. 4, pg. 8*).
7. To trigger the unit from a FACP connect signaling circuit of FACP to the terminals marked [- INPUT +] on MOM5 board (*Fig. 1, pg. 5; Fig. 2, pg. 6; Fig. 3, pg. 7; Fig. 4, pg. 8*). Polarity is shown in alarm condition. For latching fire alarm interface see *Figs. 8, 9, 10, pg. 12*.

**Note:** A 2.2K EOL must be installed across terminals marked [TRIGGER] on MOM5 board or the unit will remain in an alarm condition.

8. To trigger the unit using a supervised dry contact connect the 2.2K resistor in series for a NC trigger input and in parallel for [NO] trigger input (*Fig. 5, pg. 11*).
9. Connect auxiliary devices triggered by the unit to the terminals marked [DRY OUTPUT NO & C] on MOM5 board for normally open output or terminals marked [DRY OUTPUT NC & C] on MOM5 board for normally closed output (*Fig. 1, pg. 5; Fig. 2, pg. 6; Fig. 3, pg. 7; Fig. 4, pg. 8*).

**Note:** This relay will energize when the unit is triggered.

10. For Access Control applications batteries are optional. When batteries are not used, a loss of AC will result in the loss of output voltage. Batteries must be lead acid or gel type if used. Connect one (1) 12VDC battery to the terminals marked [+ BAT -] on power supply board for 12VDC operation (*Fig. 1, pg. 5; Fig. 2, pg. 6; Fig. 3, pg. 7; Fig. 4, pg. 8*). Use two (2) 12VDC batteries connected in series for 24VDC operation. (Battery leads included).
11. Connect supervisory trouble reporting devices to the outputs marked [AC FAIL, LOW BAT] and [Power Fail] supervisory relay outputs marked [NO, C, NC] on power supply board (*Fig. 1a, pg. 5; Fig. 2a, pg. 6; Fig. 3a, pg. 7; Fig. 4a, pg. 8*). Use 22 AWG to 18 AWG for AC Fail & Low Battery reporting.

**Note:** When used in fire alarm, burglar alarm or access control applications, "AC Fail" relay must be used to provide a visual indication of AC power on.

12. Please ensure that the cover is secured with the provided Key Lock.

### **Output Voltage and Stand-by Specification Charts:**

#### **AL300M220**

<b>Output</b>	<b>Switch Position</b>	<b>4 hr. of Stand-by &amp; 5 Minutes of Alarm</b>	<b>24 hr. of Stand-by &amp; 5 Minutes of Alarm</b>	<b>60 hr. of Stand-by &amp; 5 Minutes of Alarm</b>
12VDC/40AH Battery	Closed	Stand-by = 2.5 amp Alarm = 2.5 amp	Stand-by = 1.0 amp Alarm = 2.5 amp	Stand-by = 300mA Alarm = 2.5 amp
24VDC/12AH Battery	Open	—————	Stand-by = 200mA Alarm = 2.5 amp	—————
24VDC/40AH Battery	Open	Stand-by = 2.5 amp Alarm = 2.5 amp	Stand-by = 1.0 amp Alarm = 2.5 amp	Stand-by = 300mA Alarm = 2.5 amp

#### **AL400M220**

<b>Output</b>	<b>Switch Position</b>	<b>4 hr. of Stand-by &amp; 5 Minutes of Alarm</b>	<b>24 hr. of Stand-by &amp; 5 Minutes of Alarm</b>	<b>60 hr. of Stand-by &amp; 5 Minutes of Alarm</b>
12VDC/40AH Battery	Closed	Stand-by = 4.0 amp Alarm = 4.0 amp	Stand-by = 1.0 amp Alarm = 4.0 amp	Stand-by = 300mA Alarm = 4.0 amp
24VDC/12AH Battery	Open	—————	Stand-by = 200mA Alarm = 3.0 amp	—————
24VDC/40AH Battery	Open	Stand-by = 3.0 amp Alarm = 3.0 amp	Stand-by = 1.0 amp Alarm = 3.0 amp	Stand-by = 300mA Alarm = 2.5 amp

#### **AL600M220**

<b>Output</b>	<b>Switch Position</b>	<b>4 hr. of Stand-by &amp; 5 Minutes of Alarm</b>	<b>24 hr. of Stand-by &amp; 5 Minutes of Alarm</b>	<b>60 hr. of Stand-by &amp; 5 Minutes of Alarm</b>
12VDC/40AH Battery	Closed	Stand-by = 6.0 amp Alarm = 6.0 amp	Stand-by = 1.0 amp Alarm = 6.0 amp	Stand-by = 300mA Alarm = 6.0 amp
24VDC/12AH Battery	Open	—————	Stand-by = 200mA Alarm = 3.0 amp	—————
24VDC/40AH Battery	Open	Stand-by = 6.0 amp Alarm = 6.0 amp	Stand-by = 1.0 amp Alarm = 6.0 amp	Stand-by = 300mA Alarm = 6.0 amp

#### **AL1012M220**

<b>Output</b>	
12VDC/12AH Battery	15 Minutes of Stand-by @ 10 amp

#### **AL1024M220**

<b>Output</b>	<b>15 mins of Stand-by &amp; 5 Minutes of Alarm</b>	<b>4 hr. of Stand-by &amp; 5 Minutes of Alarm</b>	<b>24 hr. of Stand-by &amp; 5 Minutes of Alarm</b>	<b>60 hr. of Stand-by &amp; 5 Minutes of Alarm</b>
24VDC/12AH Battery	Stand-by = 7.7 amp Alarm = 9.7 amp	Stand-by = 1.2 amp Alarm = 9.7 amp	—————	—————
24VDC/65AH Battery	—————	Stand-by = 7.7 amp Alarm = 9.7 amp	Stand-by = 1.2 amp Alarm = 9.7 amp	Stand-by = 200mA Alarm = 9.7 amp

## Maintenance:

Unit should be tested at least once a year for the proper operation as follows:

**Output Voltage Test:** Under normal load conditions the DC output voltage should be checked for proper voltage level (*Output Voltage and Stand-by Specification Charts, pg. 4*).

**Battery Test:** Under normal load conditions check that the battery is fully charged, check specified voltage at the battery terminals and at the board terminals marked [+ BAT -] to ensure that there is no break in the battery connection wires.

**Note:** AL300XB220, AL400XB220, AL600XB220 and AL1012XB220 (Power Supply Board) maximum charge current is 0.7 amp.

AL1024XB220 (Power Supply Board) maximum charge current is 3.6 amp.

Expected battery life is 5 years; however, it is recommended to change batteries within 4 years or less if necessary.

Fig. 1  
AL300M220  
AL400M220

**CAUTION: De-energize unit prior to servicing. For continued protection against risk of electric shock and fire hazard replace fuses with the same type and rating (see marking on the board). Do not expose to rain or moisture.**

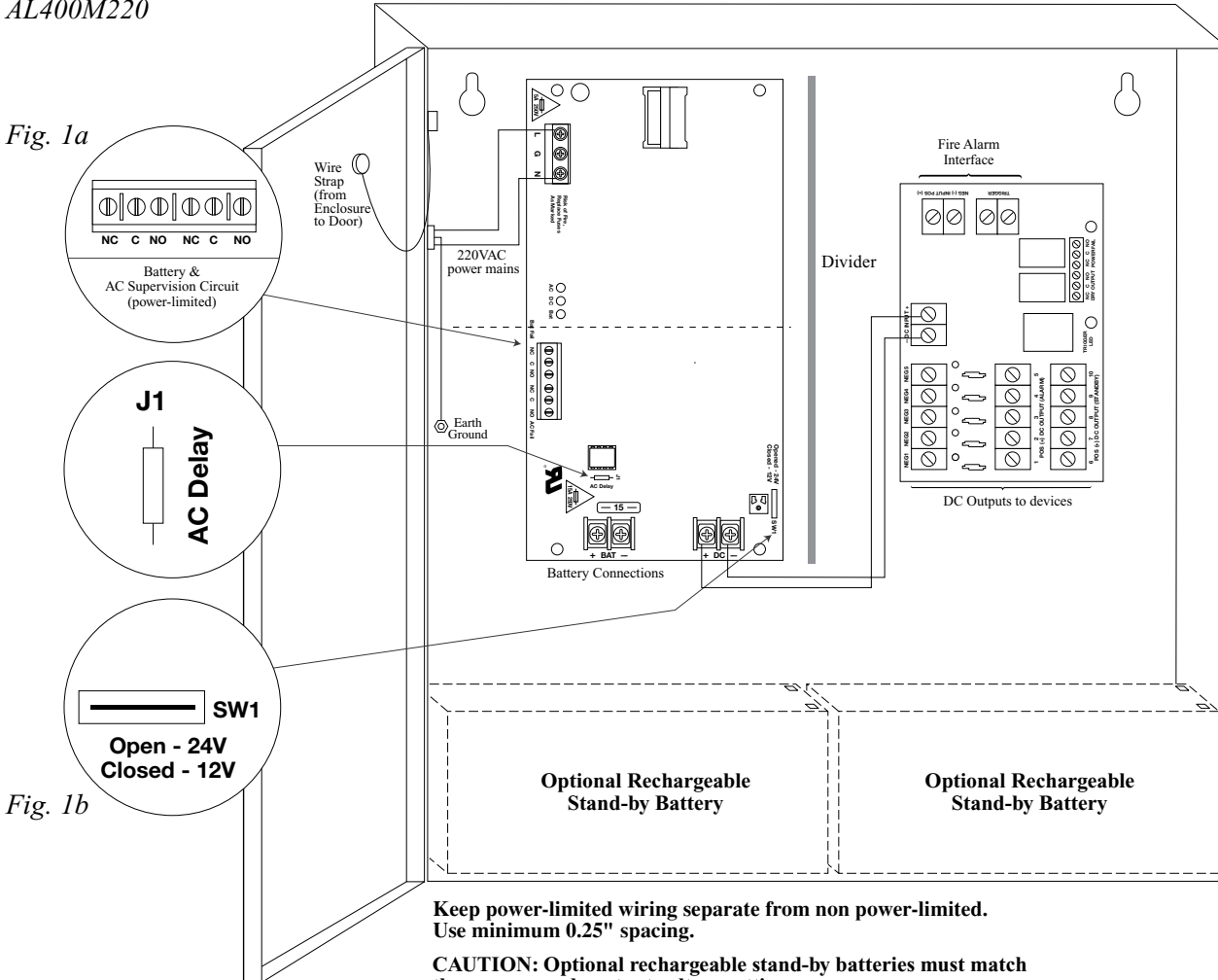

Fig. 2  
AL600M220

**CAUTION: De-energize unit prior to servicing. For continued protection against risk of electric shock and fire hazard replace fuse with the same type and rating. Do not expose to rain or moisture.**

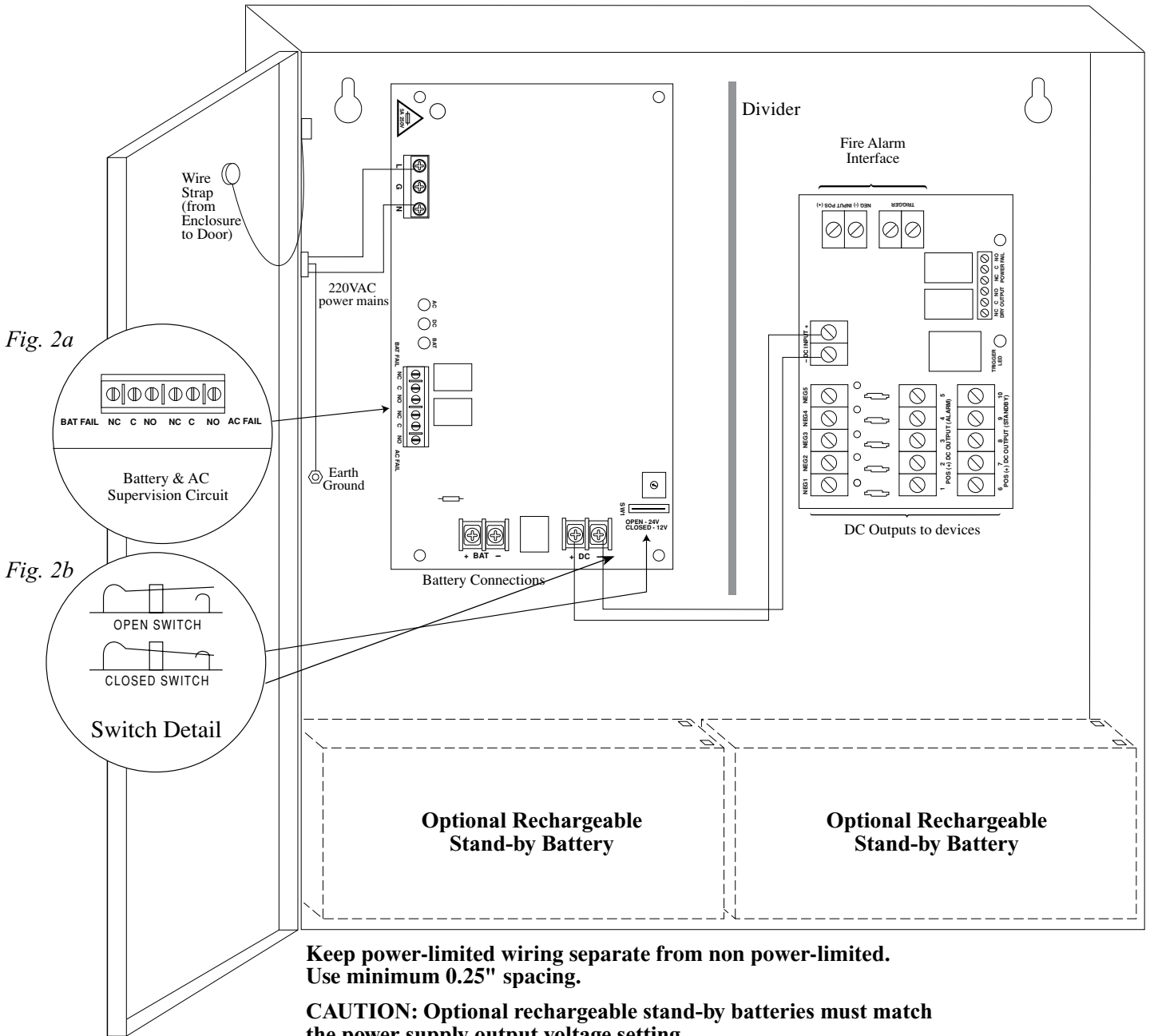

Fig. 3  
AL1012M220

**CAUTION: De-energize unit prior to servicing. For continued protection against risk of electric shock and fire hazard replace fuses with the same type and rating. Do not expose to rain or moisture.**

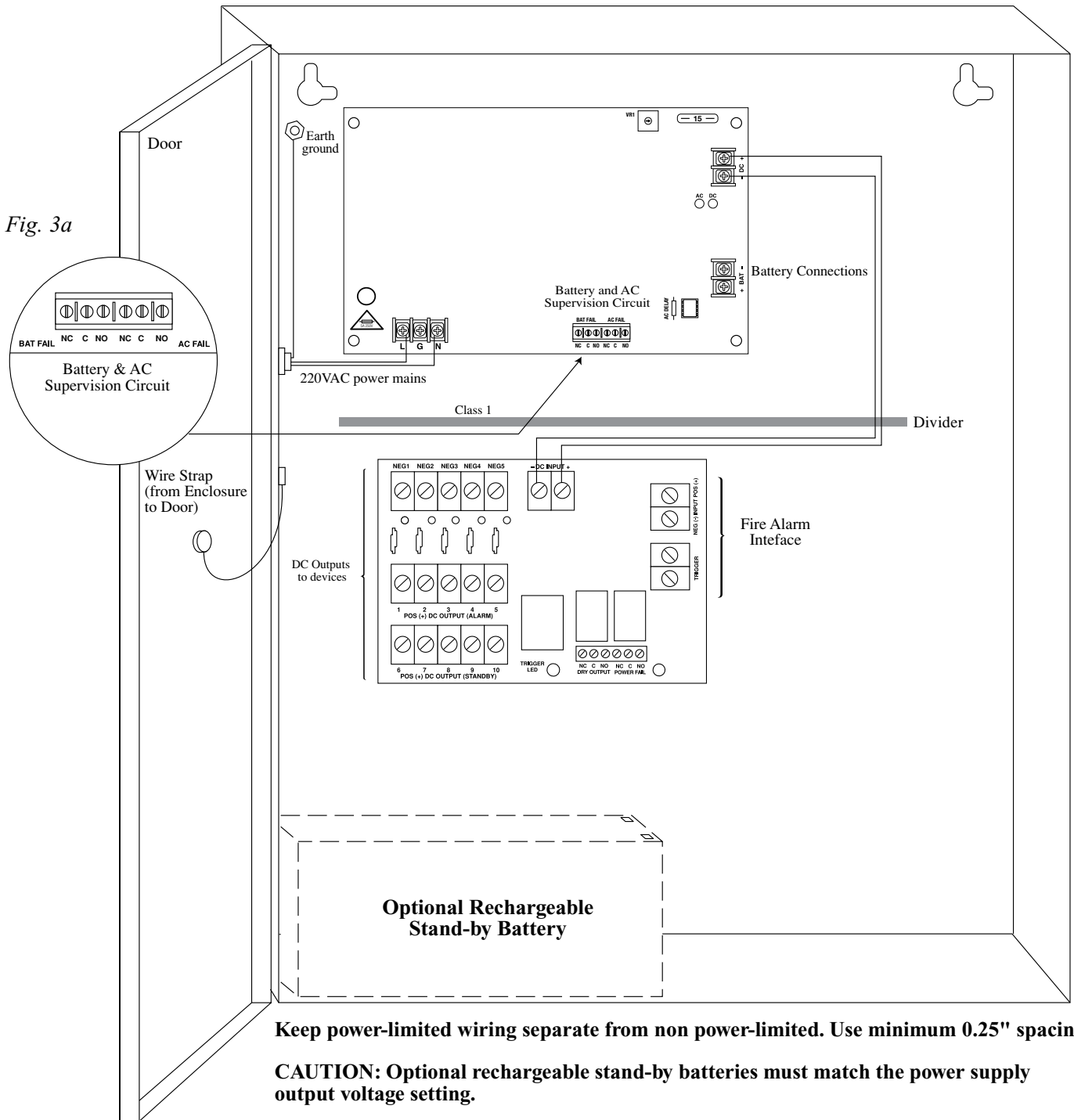
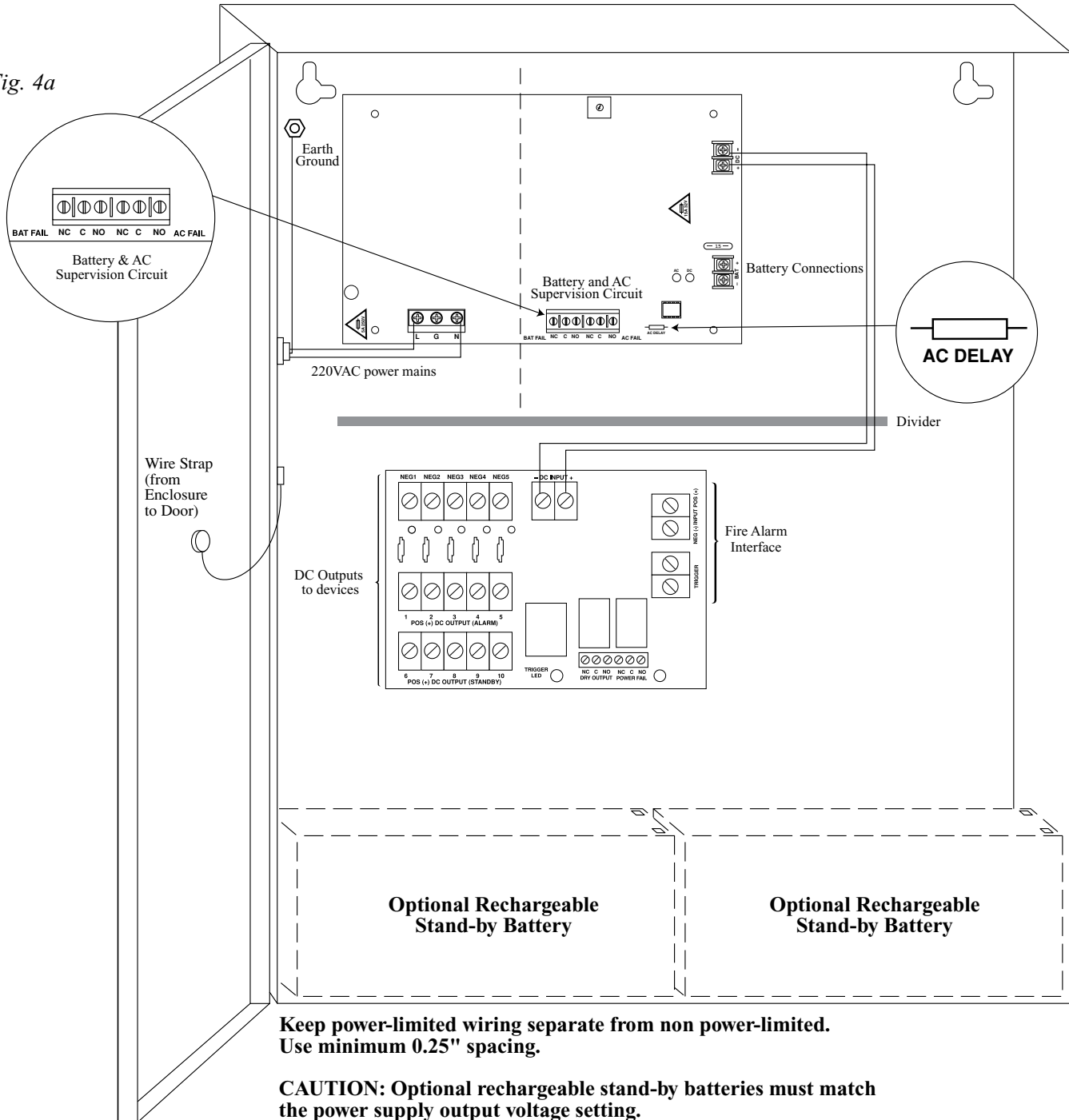

Fig. 4  
AL1024M220

**CAUTION: De-energize unit prior to servicing. For continued protection against risk of electric shock and fire hazard replace fuses with the same type and rating (see marking on the board). Do not expose to rain or moisture.**

Fig. 4a





## **LED Diagnostics:**

### **Power Supply Board**

<b>LED</b>		<b>Power Supply Status</b>
<b>Red (DC)</b>	<b>Green (AC)</b>	
ON	ON	Normal operating condition.
ON	OFF	Loss of AC, Stand-by battery supplying power.
OFF	ON	No DC output. Short circuit or thermal overload condition.
OFF	OFF	No DC output. Loss of AC. Discharged battery.

### **MOM5 - Output Module**

<b>LED</b>	<b>ON</b>	<b>OFF</b>
Power (Green)	Normal operating condition.	Power failure.
Trigger (Green)	Input is triggered (alarm condition).	No input trigger (non-alarm condition).
Outputs (Red)	Output tripped due to a short circuit or overload condition.	Normal operation.

## Terminal Identification Tables:

### Power Supply Board

Terminal Legend	Function/Description
L, G, N	Connect 220VAC 50/60Hz to these terminals: L to hot, N to neutral. Do not use the [G] terminal.
- DC +	AL300M220 - 12VDC/24VDC @ 2.5 amp to MOM5 board. AL400M220 - 12VDC @ 4 amp or 24VDC @ 3 amp to MOM5 board. AL600M220 - 12VDC/24VDC @ 6 amp to MOM5 board. AL1012M220 - 12VDC @ 10 amp to MOM5 board. AL1024M220 - 24VDC @ 10 amp to MOM5 board.
AC FAIL NC, C, NO	Indicates loss of AC power, e.g. connect to audible device or alarm panel. Relay normally energized when AC power is present. Contact rating 1 amp @ 28VDC. AC or brownout fail is reported within 1 minute of event. To delay reporting for up to 6 hrs., cut "AC delay" jumper and reset power to the unit.
BAT FAIL NC, C, NO	Indicates low battery condition, e.g. connect to alarm panel. Relay normally energized when DC power is present. Contact rating 1 amp @ 28VDC. A removed battery is reported within 5 minutes. Battery reconnection is reported within 1 minute. Low battery threshold: 12VDC output threshold set @ approximately 10.5VDC (N/A for AL1024M220), 24VDC output threshold set @ approximately 21VDC.
+ BAT -	Stand-by battery connections. AL300XB220, AL400XB220 and AL600XB220 (Power Supply Board) maximum charge current is 0.7 amp. AL1024XB220 (Power Supply Board) maximum charge current is 3.6 amp.

### MOM5 - Output Module

Terminal Legend	Function/Description
- DC INPUT +	12VDC or 24VDC from power supply.
TRIGGER	Dry normally open [NO] or normally closed [NC] supervised (2.2K EOL resistor) input trigger. A short or open circuit will transfer power from terminals marked [POS. (+) DC OUTPUT (STAND-BY)] to terminals marked [POS (+) DC OUTPUT (ALARM)].
- INPUT +	Wet (5-30VDC) input trigger. Applying voltage to these terminals in the polarity shown will transfer power from terminals marked [POS. (+) DC OUTPUT (STAND-BY)] to terminals marked [POS (+) DC OUTPUT (ALARM)] (e.g. fire alarm control panel indications circuit).
NEG 1 THROUGH NEG 5	Supplies constant negative (-) voltage.
POS (+) DC OUTPUT (ALARM) 1-5	Supplies positive (+) voltage when dry trigger input or fire alarm wet trigger input is applied.
POS (+) DC OUTPUT (STAND-BY) 6-10	Supplies positive (+) voltage in normal condition. Power is removed when dry trigger input or fire alarm wet trigger input is applied.
NC, C, NO DRY OUTPUT	When the MOM5 is triggered the terminals marked [C and NO] will open and the terminals marked [C and NC] will close. This output is used to trigger auxiliary devices. (e.g. HVAC Shutdown, Elevator Recall etc.) Contact rating 1 amp @ 28VDC.
NC, C, NO POWER FAIL	Form "C" contacts used for reporting no voltage is present at [-- DC input +] terminals. Under normal conditions, terminals marked [NO and C] are open, [NC and C] are closed. A loss of power causes terminals marked [NO and C] to close and [NC and C] to open. Contact rating 1 amp @ 28VDC.

## Typical Application Diagrams:

Fig. 5 MOM5 module shown with wet and/or dry normally closed trigger inputs (Non-Latching):

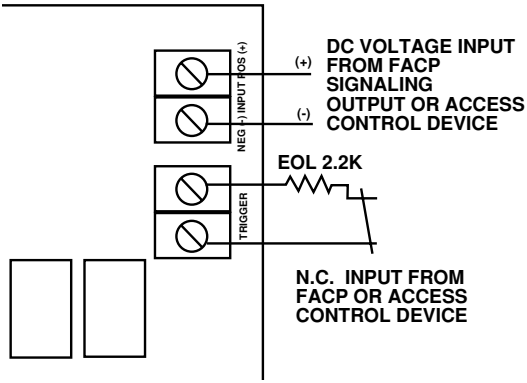

MOM5 module shown with wet and/or dry normally open trigger inputs (Non-Latching):

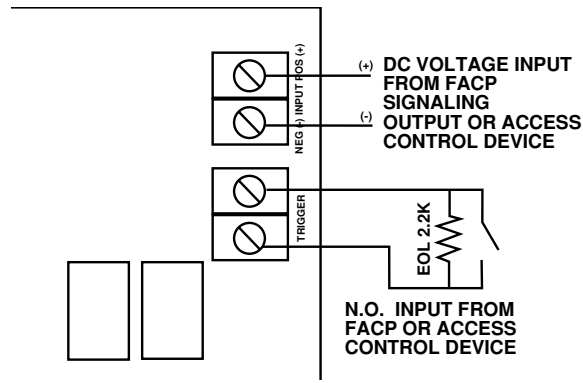

Fig. 6 - Two (2) or more MOM5 modules shown with wet and/or dry normally closed trigger inputs (Non-Latching):

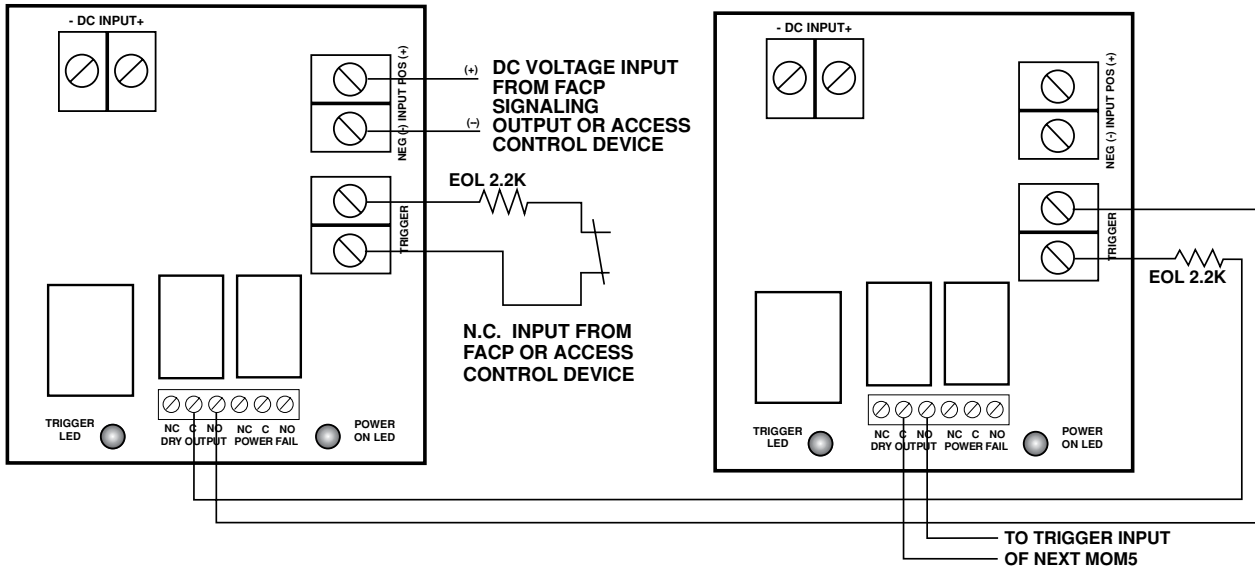
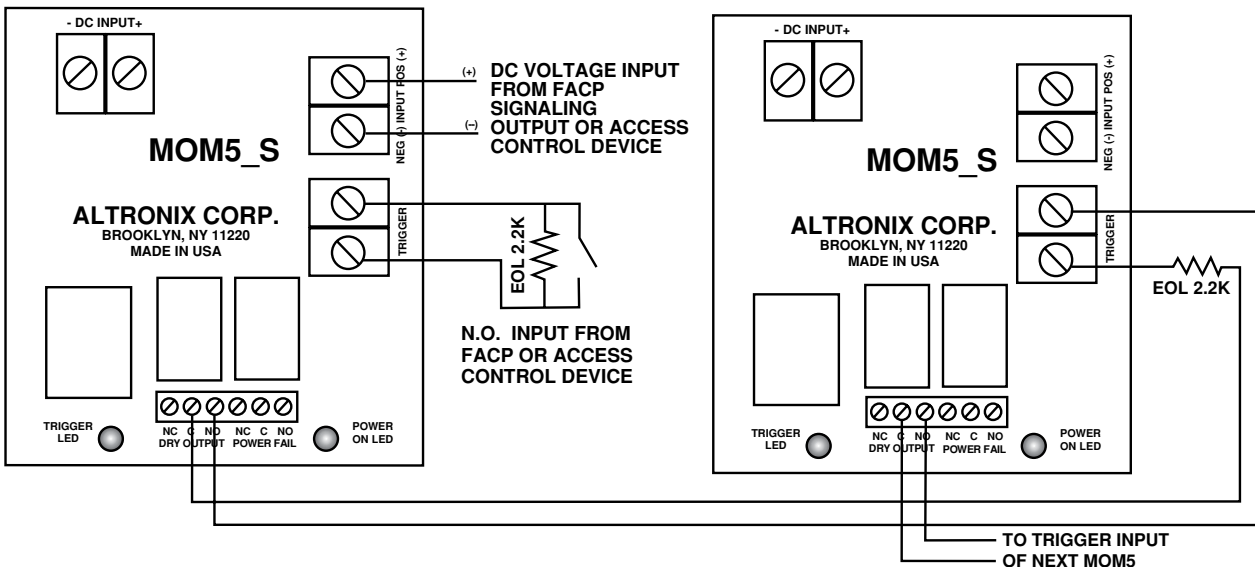
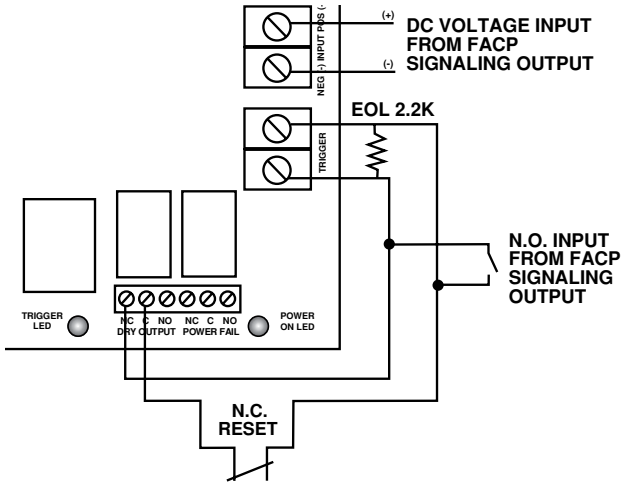

Fig. 7 - Two (2) or more MOM5 modules shown with wet and/or dry normally open trigger inputs (Non-Latching):



## Typical Application Diagrams (cont'd.):

**Fig. 8** MOM5 module shown with with wet and/or dry normally open fire alarm trigger inputs  
**(Latching with Manual Reset):**



MOM5 module shown with with wet and/or dry normally closed fire alarm trigger inputs  
**(Latching with Manual Reset):**

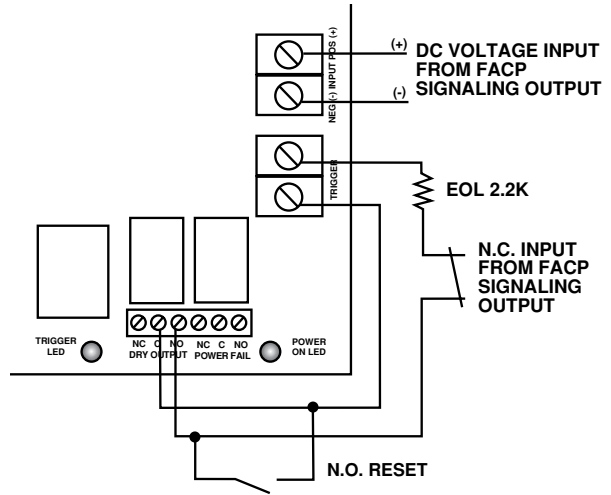

**Fig. 9** - Two (2) MOM5 modules shown with wet and/or dry normally closed fire alarm trigger inputs  
**(Latching with Manual Reset):**

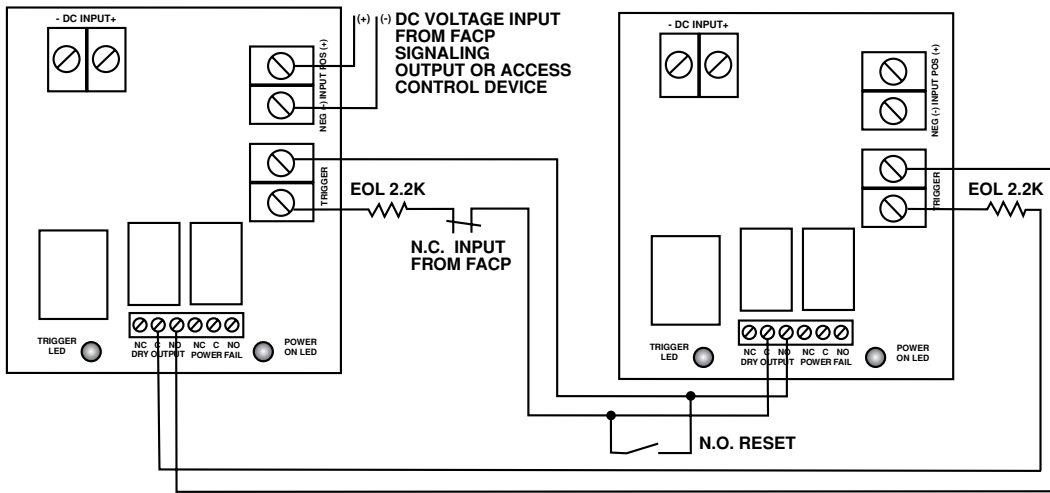

**Fig. 10** - Two (2) MOM5 modules shown with wet and/or dry normally open fire alarm trigger inputs  
**(Latching with Manual Reset):**

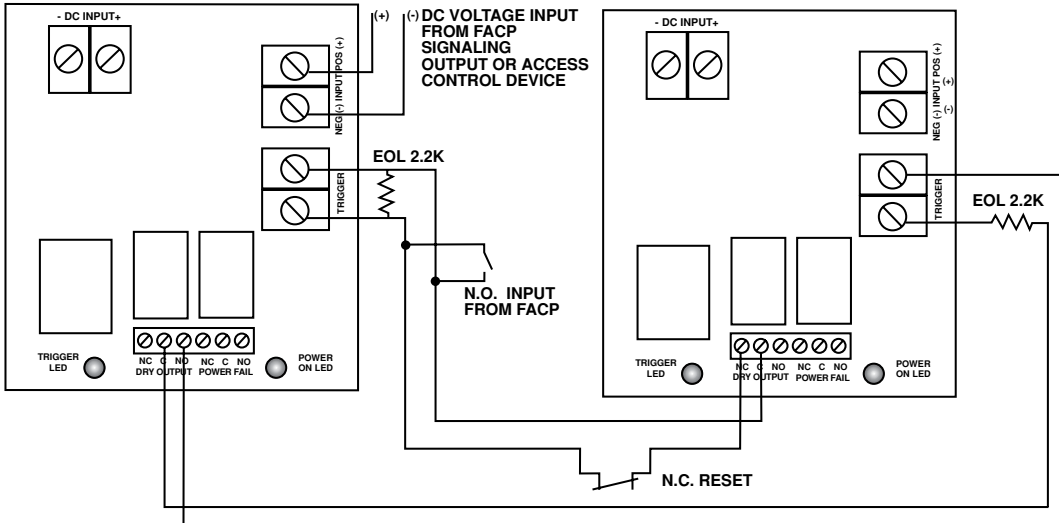

**Enclosure Dimensions (BC300):**

**AL300M220, AL400M220, AL600M220**

13.5" x 13" x 3.25" (342.9mm x 330.2mm x 82.55mm)

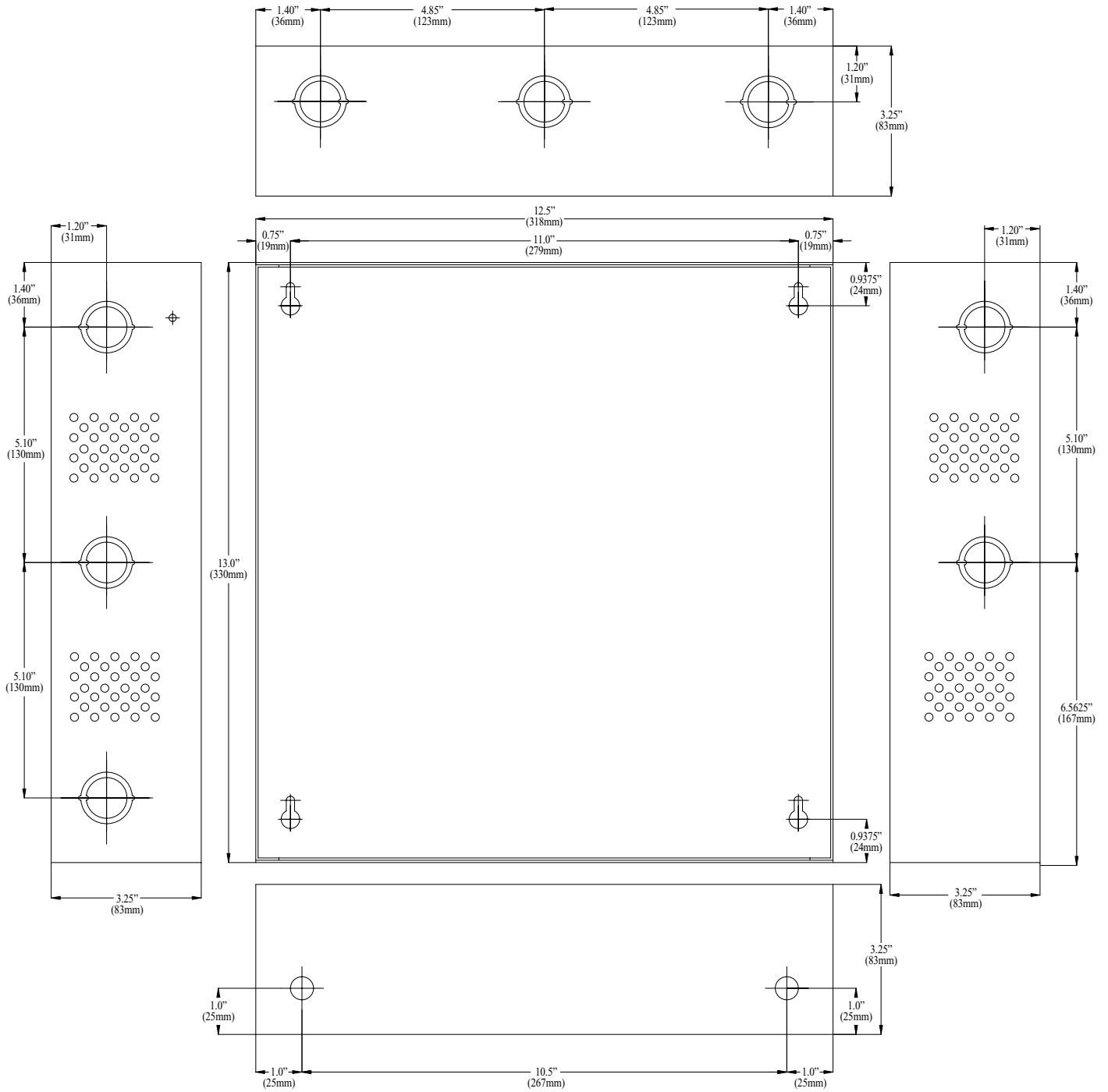

**Enclosure Dimensions (BC400):**

**AL1012M220, AL1024M220**

15.5" x 12" x 4.5" (393.7mm x 304.8mm x 114.3mm)

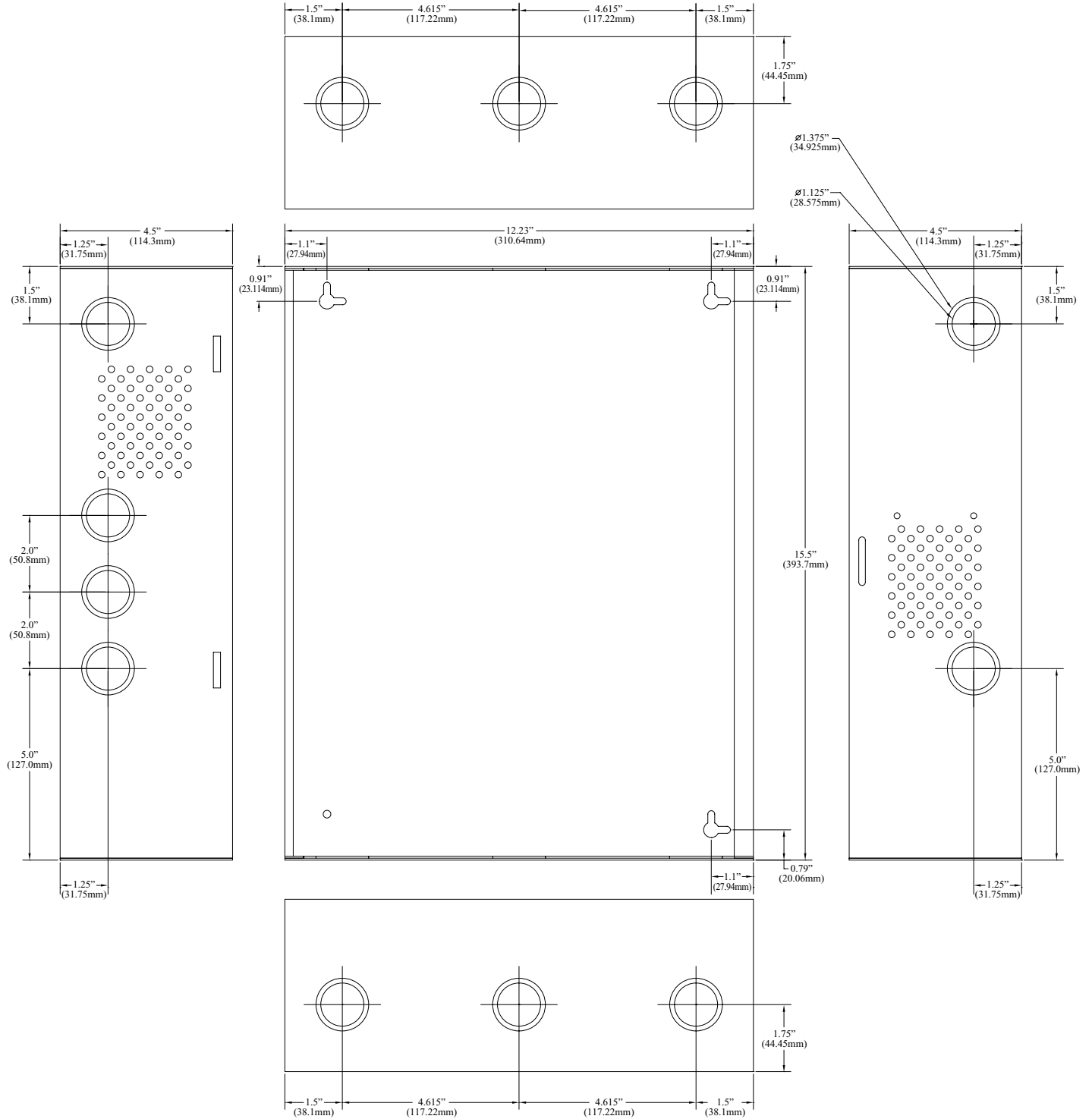

**Notes:**

## **Notes:**

Altronix is not responsible for any typographical errors.

140 58th Street, Brooklyn, New York 11220 USA, 718-567-8181, fax: 718-567-9056  
web site: [www.altronix.com](http://www.altronix.com), e-mail: [info@altronix.com](mailto:info@altronix.com), Lifetime Warranty, Made in U.S.A.  
IIM220series

H11N

- 16 -

