

# MAXIMAL™ *Access Power Controllers with Power Supplies*

## *Installation Guide for models:*

### **Maximal3F**

- 12VDC @ 4.6 amp or 24VDC @ 5.2 amp.
- Sixteen (16) fuse protected non power-limited outputs.

### **Maximal5F**

- 12VDC @ 8.6 amp.
- Sixteen (16) fuse protected non power-limited outputs.

### **Maximal7F**

- 24VDC @ 9.2 amp.
- Sixteen (16) fuse protected non power-limited outputs.

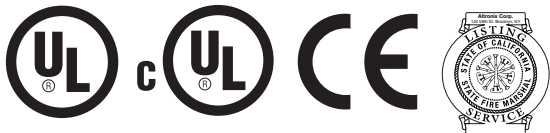

Rev. SFF051313

**More than just power.™**

Installing Company: \_\_\_\_\_ Service Rep. Name: \_\_\_\_\_

Address: \_\_\_\_\_ Phone #: \_\_\_\_\_

## **MaximalF Series Overview:**

MaximalF Access Power/Controllers distribute and switch power to access control systems and accessories. They convert a 120VAC 60Hz input into sixteen (16) independently controlled 12VDC or 24VDC fuse protected outputs. These Fail-Safe/Fail-Secure power outputs may be converted to dry form “C” contacts. The outputs are activated by an open collector sink or normally open (NO) dry trigger input from an Access Control System, Keypad, Push Button, REX PIR, etc. Units will route power to a variety of access control hardware devices including: Mag Locks, Electric Strikes, Magnetic Door Holders, etc. The FACP Interface enables Emergency Egress, Alarm Monitoring, or may be used to trigger other auxiliary devices. The fire alarm disconnect feature is individually selectable for any or all of the sixteen (16) outputs. All interconnecting equipment must be UL Listed.

## **MaximalF Series Configuration Chart:**

Altronix Model Number	Nominal DC Output Voltage				Maximum Supply Current for Main and Aux. Outputs on Power Supply board and ACM8 Access Power Controller's outputs (amp)	Fuse Protected Non Power-Limited Outputs	120VAC 60Hz Input (Current)	Current Per ACM8 Output (amp)	Power Supply Board Input Fuse Rating	Power Supply Board Battery Fuse Rating	ACM8 Board Input Fuse Rating	ACM8 Board Output Fuse Rating
	[DC]		[Aux]									
	12VDC Output Range (volts)	24VDC Output Range (volts)	12VDC Output Range (volts)	24VDC Output Range (volts)								
<b>Maximal3F</b>	10.0-13.2	20.19-26.4	10.03-13.2	20.19-26.4	12VDC @ 4.6 amp or 24VDC @ 5.2 amp	16	3.5	2.5	5A/250V	10A/32V	10A/250V	2.5A/250V
<b>Maximal5F</b>	10.03-13.2	—	10.03-13.2	—	8.6 amp	16	3.5	2.5	5A/250V	15A/32V	10A/250V	2.5A/250V
<b>Maximal7F</b>	—	20.17-26.4	—	20.28-26.4	9.2 amp	16	4.5	2.5	6.3A/250V	15A/32V	10A/250V	2.5A/250V

The DC output for these power supplies are not power-limited. If a power-limited output is required in the end-product application, the DC output from the power supply must be connected to a separately Listed control unit or accessory board that provides power-limited outputs. The product(s) providing the power-limited output(s) must be listed as appropriate for the particular end-product application (access control), and wired in accordance with the products installation instructions. Class 1 wiring methods, separation of circuits, and proper fire-rated enclosures all must be considered when connecting the DC output of the power supply to the end-product devices. The auxiliary outputs of these units are power-limited.

\* **UL Listings for US Installations:** UL 294 - UL Listed for Access Control System Units.

**UL Listings for Canadian Installations:** ULC-S319-05 - Electronic Access Control Systems Class I equipment. CSA C22.2 No.205 - Signal Equipment.

ULC-S319-05 Electronic Access Control Systems will be invalidated through the use of any add-on, expansion, memory or other module manufactured by the manufacturer or other manufacturers.

## **MaximalF Series Features:**

### **ACM8 Access Power Controller Modules:**

- Sixteen (16) independently trigger controlled outputs. Output options:
  - a) Sixteen (16) Fail-Safe filtered power outputs.
  - b) Sixteen (16) Fail-Secure filtered power outputs.
  - c) Sixteen (16) form “C” relay outputs (rated @ 5 amp/28VDC or VAC).
  - d) Any combination of the above.
- Sixteen (16) Access Control System trigger inputs. Input trigger options:
  - a) Sixteen (16) normally open (NO) dry trigger inputs.
  - b) Sixteen (16) open collector inputs.
  - c) Any combination of the above.
- Sixteen (16) unswitched filtered aux. power outputs (outputs are rated @ 2.5 amp).
- Red LEDs on ACM8 board indicate individual outputs are triggered (relays energized).
- Fire Alarm disconnect (latching or non-latching) is individually selectable for any or all of the eight (8) outputs.
 

Fire Alarm disconnect input trigger options:

  - a) Normally open (NO) or normally closed (NC) dry trigger input.
  - b) Polarity reversal input from FACP signaling circuit.
- Green LED on ACM8 board indicates FACP disconnect is triggered.
- FACP output relay indicates that FACP input is triggered (form “C” contact rated @ 1 amp/28VDC not evaluated by UL).
- eFlow Power Supply/Charger board provides common power for both ACM8 access power controller boards (factory wiring) and all connected access control devices (field wiring).
- ACM8 board main fuses are rated @ 10 amp. Output fuses are rated @ 2.5 amp.

## **eFlow Power Supply/Charger:**

- Input: 120VAC, 60Hz.
  - For output voltage and supply current, refer to *MaximalF series Configuration Chart, pg. 2*.
  - Auxiliary Power-Limited output rated @ 1 amp (unswitched).
  - Over Voltage Protection.
  - Built-in charger for sealed lead acid or gel type batteries.
  - Maximum charge current 1.54 amp.
  - Automatic switch over to stand-by battery when AC fails. Transfer to stand-by battery power is instantaneous with no interruption.
  - Supervised Fire Alarm disconnect (latching or non-latching) 10K EOL resistor. Operates on a normally open (NO) or normally closed (NC) trigger.
  - AC fail supervision (form “C” contacts).
  - Battery fail & presence supervision (form “C” contacts).
  - Low power shutdown. Shuts down DC output terminals if battery voltage drops below 71-73% for 12V units and 70-75% for 24V units (depending on the power supply). Prevents deep battery discharge.
  - Fuse ratings, refer to *MaximalF series Configuration Chart, pg. 2*.
  - Green AC Power LED indicates 120VAC present.
  - AC input and DC output LED indicators.
  - Short circuit and overload protection.
  - Enclosure accommodates up to four (4) 12VDC/12AH batteries.
- Enclosure dimensions (HxWxD): 26” x 19” x 6.25” (660.4mm x 482.6mm x 158.75mm)

### **MaximalF Installation Instructions:**

Wiring methods shall be in accordance with the National Electrical Code/NFPA 70/ANSI, The Canadian Electric Code, Part I, Part II, and with all local codes and authorities having jurisdiction. Product is intended for indoor use only.

<i>Power Supply Board LED Diagnostics</i>	<i>(pg. 5)</i>
<i>Access Power Controller LED Diagnostics</i>	<i>(pg. 5)</i>
<i>Power Supply Board Terminal Identification</i>	<i>(pg. 5)</i>
<i>Access Power Controller Terminal Identification</i>	<i>(pg. 5)</i>
<i>Power Supply Board Stand-by Battery Specifications</i>	<i>(pg. 6)</i>
<i>Power Supply Board Output Voltage Settings</i>	<i>(pg. 6)</i>
<i>Access Power Controller Typical Application Diagram</i>	<i>(pg. 6)</i>
<i>FACP Hook-up Diagrams</i>	<i>(pg. 9)</i>

1. Mount unit in desired location. Mark and predrill holes in the wall to line up with the top three keyholes in the enclosure. Install three upper fasteners and screws in the wall with the screw heads protruding. Place the enclosure’s upper keyholes over the three upper screws, level and secure. Mark the position of the lower three holes. Remove the enclosure. Drill the lower holes and install the three fasteners. Place the enclosure’s upper keyholes over the three upper screws. Install the three lower screws and make sure to tighten all screws  
*(Enclosure Dimensions, pg. 12)*.
2. Connect unswitched AC power (120VAC 60Hz) to terminals marked [L, N] *(Fig. 3, pg. 7)*. Do not use terminal marked [G]. Use 14 AWG or larger for all power connections. Secure green wire lead attached to the chassis to earth ground.  
**Keep power-limited wiring separate from non power-limited wiring. Minimum 0.25” spacing must be provided (Fig. 3, pg. 7).**  
**CAUTION: Do not touch exposed metal parts. Shut branch circuit power before installing or servicing equipment.**  
**There are no user serviceable parts inside. Refer installation and servicing to qualified service personnel.**
3. Select desired DC output voltage by setting SW1 to the appropriate position on the Maximal3F power supply *(Fig. 1a, pg. 6)*. Maximal5F power supply is factory set at 12VDC and Maximal7F power supply is factory set at 24VDC.
4. Measure the output voltage of the unit before connecting any devices to ensure proper operation. Improper or high voltage will damage these devices.
5. **Output options** *(Fig. 2, pg. 6)*:  
The unit will provide either sixteen (16) switched power outputs, sixteen (16) dry form “C” outputs, or any combination of both switched power and form “C” outputs.
  - (a) **Fail-Safe Switched Power outputs:**  
For Fail-Safe operation connect the positive (+) input of the access control devices to terminal marked [NC]. Connect the negative (-) input of the access control devices to terminal marked [COM].
  - (b) **Fail-Secure Switched Power outputs:**  
For Fail-Secure operation connect the positive (+) input of the access control devices to terminal marked [NO]. Connect the negative (-) input of the access control devices to terminal marked [COM].
  - (c) **Form “C” outputs:**  
When form “C” outputs are desired the corresponding output fuses (1-8) of each ACM8 board must be removed.
6. **ACM8 Auxiliary Power outputs (unswitched):**  
Connect access control devices that require constant power to terminals marked [C] positive (+) and [COM] negative (-). Outputs can be used to provide power for card readers, keypads etc.  
**eFlow Auxiliary outputs (unswitched):**  
For auxiliary device connection this output will not be affected by Low Power Disconnect or Fire Alarm Interface. Connect device to terminals marked [+ AUX -] *(Fig. 3, pg. 7)*.

7. **Input trigger options** (*Fig. 2, pg. 6*):
  - (a) **Normally Open [NO] input trigger:**  
Inputs 1-8 are activated by normally open or open collector sink inputs. Connect access control panel outputs, keypads, push buttons, REX PIRs, etc. to terminals marked [IN] and [GND].
  - (b) **Open Collector Sink inputs:**  
Connect the access control panel open collector sink positive (+) to terminals marked [IN] and the negative (-) to terminals marked [GND].
8. **ACM8 Fire Alarm Interface options** (*Figs. 5-9, pg. 9*):  
A normally closed [NC] or normally open [NO] input trigger from a fire alarm control panel or a polarity reversal input from an FACP signaling circuit will affect selected outputs. To enable FACP Disconnect for an output, open the corresponding switch(es) [SW1-SW8] on each ACM8 board. To disable FACP disconnect for an output, close the corresponding switch(es) [SW1-SW8] on each ACM8 board.
  - (a) **Normally Open [NO] input:**  
For non-latching hook-up refer to (*Fig. 6, pg. 9*). For latching hook-up refer to (*Fig. 7, pg. 9*).
  - (b) **Normally Closed [NC] input:**  
For non-latching hook-up refer to (*Fig. 8, pg. 9*). For latching hook-up refer to (*Fig. 9, pg. 9*).
  - (c) **FACP Signaling Circuit input trigger:**  
Connect the positive (+) and negative (-) from the FACP signaling circuit output to the terminals marked [+ INP -]. Connect the FACP EOL to the terminals marked [+ RET -] (polarity is referenced in an alarm condition). Jumper J3 must be cut (*Fig. 5, pg. 9*).
9. **FACP Dry form “C” output** (*Fig. 2a, pg. 6*) (Not evaluated by UL):  
FACP form “C” contacts can be used to trigger reporting or signaling devices. These contact switch upon a fire alarm input trigger to the ACM8 boards.
10. **Stand-by Battery Connections** (*Figs. 3, pg. 7*):  
For U.S. Access Control applications batteries are optional. Batteries are required for Canadian installations (ULC-S319). When batteries are not used, a loss of AC will result in the loss of output voltage. When the use of stand-by batteries is desired, they must be lead acid or gel type.  
Connect battery to terminals marked [- BAT +] (*Fig. 3, pg. 7*). Use two (2) 12VDC batteries connected in series for 24VDC operation (battery leads included). Use batteries - Casil CL1270 (12V/7AH), CL12120 (12V/12AH), CL12400 (12V/40AH), CL12650 (12V/65AH) batteries or UL recognized BAZR2 and BAZR8 batteries of an appropriate rating.
11. **Battery and AC Supervision outputs** (*Fig. 3, pg. 7*):  
It is required to connect supervisory trouble reporting devices to outputs marked [AC Fail, BAT Fail] supervisory relay outputs marked [NC, C, NO] to appropriate visual notification devices. Use 22 AWG to 18 AWG for AC Fail & Low/No Battery reporting.
12. To delay AC reporting for 2 hrs., set dip switch [AC Delay] to OFF position (*Fig. 3, pg. 7*).  
To delay AC reporting for 1 min., set dip switch [AC Delay] to ON position (*Fig. 3, pg. 7*).
13. **Low Power Shutdown** (*Fig. 3, pg. 7*):  
To enable Low Output Power Shutdown, set dip switch [Shutdown] to ON position.  
To disable Low Output Power Shutdown, set dip switch [Shutdown] to OFF position.
14. **Installation of tamper switch (Not Included)** (*Fig. 3b, pg. 7*):  
Mount UL Listed tamper switch (Sentrol model 3012 or equivalent) at the top of the enclosure. Slide the tamper switch bracket onto the edge of the enclosure approximately 2” from the right side (*Fig. 3b, pg. 7*).  
Connect tamper switch wiring to the Access Control Panel input or the appropriate UL Listed reporting device.  
To activate alarm signal, open the door of the enclosure.
15. **Multiple power supply inputs** (*Fig. 2, pg. 6*) (Not evaluated by UL):  
When using an additional Listed external power supply, jumpers J1 and J2 located on corresponding ACM8 board must be cut (*Fig. 2b, pg. 6 & Fig. 5, pg. 9*). Connect external Listed power-limited access control power supply to the terminals marked [- Control +] (These terminals are paralleled to the - Power + terminals). When using DC power supplies, polarity must be observed. When using AC power supplies, polarity need not be observed. All field wiring connections must be made employing suitable gauge CM or FPL jacketed wire (or equivalent substitute) (*Fig. 4a, pg. 8*).

### **Maintenance:**

Unit should be tested at least once a year for the proper operation as follows:

**FACP Supervision:** To ensure proper connection and operation of the Fire Alarm disconnect hookup.

Please follow the appropriate procedure below:

**Normally Open Input:** Placing a short between terminals marked [T] and [+ INP] will trigger the Fire Alarm Disconnect. Remove the short to reset.

**Normally Closed Input:** Remove the wire from terminal marked [INP -] will trigger the Fire Alarm Disconnect. Replace the wire to terminal marked [INP -] to reset.

**FACP Signal Circuit Input:** It is necessary to trigger the Fire Alarm System.

In all of the above scenarios the green TRG LED of the ACM8s will illuminate. All outputs selected for Fire Alarm Disconnect will activate releasing locking devices.

**Note:** All outputs [OUT 1 - OUT 8] must be in a normal (de-energized) condition prior to testing. When the unit is configured for Normally Open (*Fig. 7, pg. 9*) or Normally Closed (*Fig. 9, pg. 9*) latching operation it is necessary to reset the Fire Alarm Disconnect by activating the Normally Closed reset switch.

**Output Voltage Test:** Under normal load conditions, the DC output voltage should be checked for proper voltage level (refer to *MaximalF series Configuration Chart, pg. 2*).

**Battery Test:** Under normal load conditions check that the battery is fully charged, check specified voltage at the battery terminals and at the board terminals marked [+ BAT -] to ensure that there is no break in the battery connection wires.

**Note:** Maximum charge current is 1.54 amp.

Expected battery life is 5 years; however, it is recommended to change batteries within 4 years or less if necessary.

### **Power Supply Board LED Diagnostics:**

Red (DC)	Green (AC/AC1)	Power Supply Status
ON	ON	Normal operating condition.
ON	OFF	Loss of AC, Stand-by battery supplying power.
OFF	ON	No DC output.
OFF	OFF	Loss of AC. Discharged or no stand-by battery. No DC output.

### **Access Power Controller LED Diagnostics:**

LED	ON	OFF
LED 1- LED 8 (Red)	Output relay(s) energized.	Output relay(s) de-energized.
Trg (Green)	FACP input triggered (alarm condition).	FACP normal (non-alarm condition).

### **Power Supply Board Terminal Identification:**

Terminal Legend	Function/Description
L, N	Connect 120VAC 60Hz to these terminals: L to hot, N to neutral. Do not use terminal marked [G]
+ DC -	Factory connected to ACM8 board.
Trigger EOL Supervised	Fire Alarm Interface trigger input from a short or FACP. Trigger inputs can be normally open, normally closed from an FACP output circuit (power-limited input) ( <i>Fig. 3, pg. 7</i> ).
NO, GND RESET	FACP interface latching or non-latching (power-limited) ( <i>Fig. 3, pg. 7</i> ).
+ AUX -	Auxiliary Power-Limited output rated @ 1 amp (unswitched) (power-limited output) ( <i>Fig. 3, pg. 7</i> ).
AC FAIL NC, C, NO	Indicates loss of AC power, e.g. connect to audible device or alarm panel. Relay normally energized when AC power is present. Contact rating 1 amp @ 30VDC (power-limited) ( <i>Fig. 3, pg. 7</i> ).
BAT FAIL NC, C, NO	Indicates low battery condition, e.g. connect to alarm panel. Relay normally energized when DC power is present. Contact rating 1 amp @ 30VDC. A removed battery is reported within 5 minutes. Battery reconnection is reported within 1 minute (power-limited) ( <i>Fig. 3, pg. 7</i> ).
+ BAT -	Stand-by battery connections. Maximum charge current 1.54 amp (non power-limited) ( <i>Fig. 3, pg. 7</i> ).

### **Access Power Controller Terminal Identification:**

Terminal Legend	Function/Description
- Power +	12VDC or 24VDC from power supply/charger (factory connected). These terminals are paralleled to the - Control + terminals.
- Control +	These terminals are paralleled to the - Power + terminals. These terminals can be connected to an external Listed power-limited access control power supply to provide isolated operating power for the devices (Not evaluated by UL) (jumpers J1 and J2 must be removed).
TRIGGER INPUT 1-INPUT 8 IN, GND	From normally open and/or open collector sink trigger inputs (request to exit buttons, exit pir's, etc.)
OUTPUT 1- OUTPUT 8 NC, C, NO, COM	12VDC to 24VDC trigger controlled outputs are rated at 2.5 amp. Maximal3F - 10.0-13.2VDC @ 4.6 amp or 20.19-26.4VDC @ 5.2 amp. Maximal5F - 10.03-13.2VDC @ 8.6 amp. Maximal7F - 20.17-26.4VDC @ 9.2 amp. Fail-Safe [NC positive (+) & COM Negative (-)], Fail-Secure [NO positive (+) & COM Negative (-)], Auxiliary output [C positive (+) & COM Negative (-)] (When using AC power supplies polarity needs not to be observed), NC, C, NO convert to dry form "C" 5 amp 24VAC/VDC rated dry outputs when fuses are removed. Contacts shown in a non-triggered state.
FACP INTERFACE T, + INPUT -	Fire Alarm Interface trigger input from FACP. Trigger inputs can be normally open, normally closed from an FACP signaling circuit output ( <i>Figs. 5-9, pg. 9</i> ).
FACP INTERFACE NC, C, NO	Form "C" relay contact rated @ 1 amp 28VDC for alarm reporting (not evaluated by UL).

## Power Supply Board Stand-by Battery Specifications:

Battery	Maximal3F	Maximal5F	Maximal7F
7AH	10 Mins./6 amp	5 Mins./10 amp	5 Mins./10 amp
12AH	30 Mins./6 amp*	30 Mins./10 amp*	30 Mins./10 amp*
40AH	Over 4 Hours/6 amp*	Over 2 Hours/10 amp*	Over 2 Hours/10 amp*
65AH	Over 4 Hours/6 amp*	Over 4 Hours/10 amp*	Over 4 Hours/10 amp*

\*Only these configurations can be utilized in ULC-S319 installations.

## Power Supply Board Output Voltage Settings:

Fig. 1

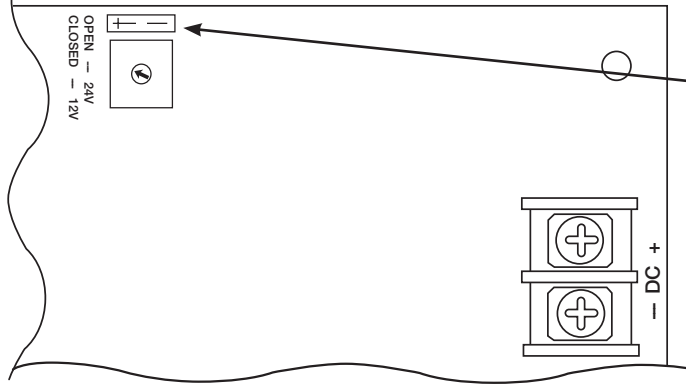
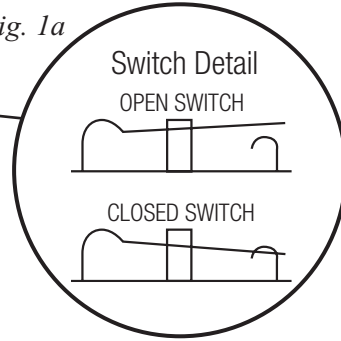

Fig. 1a



## Access Power Controller Typical Application Diagram (for each ACM8):

Fig. 2

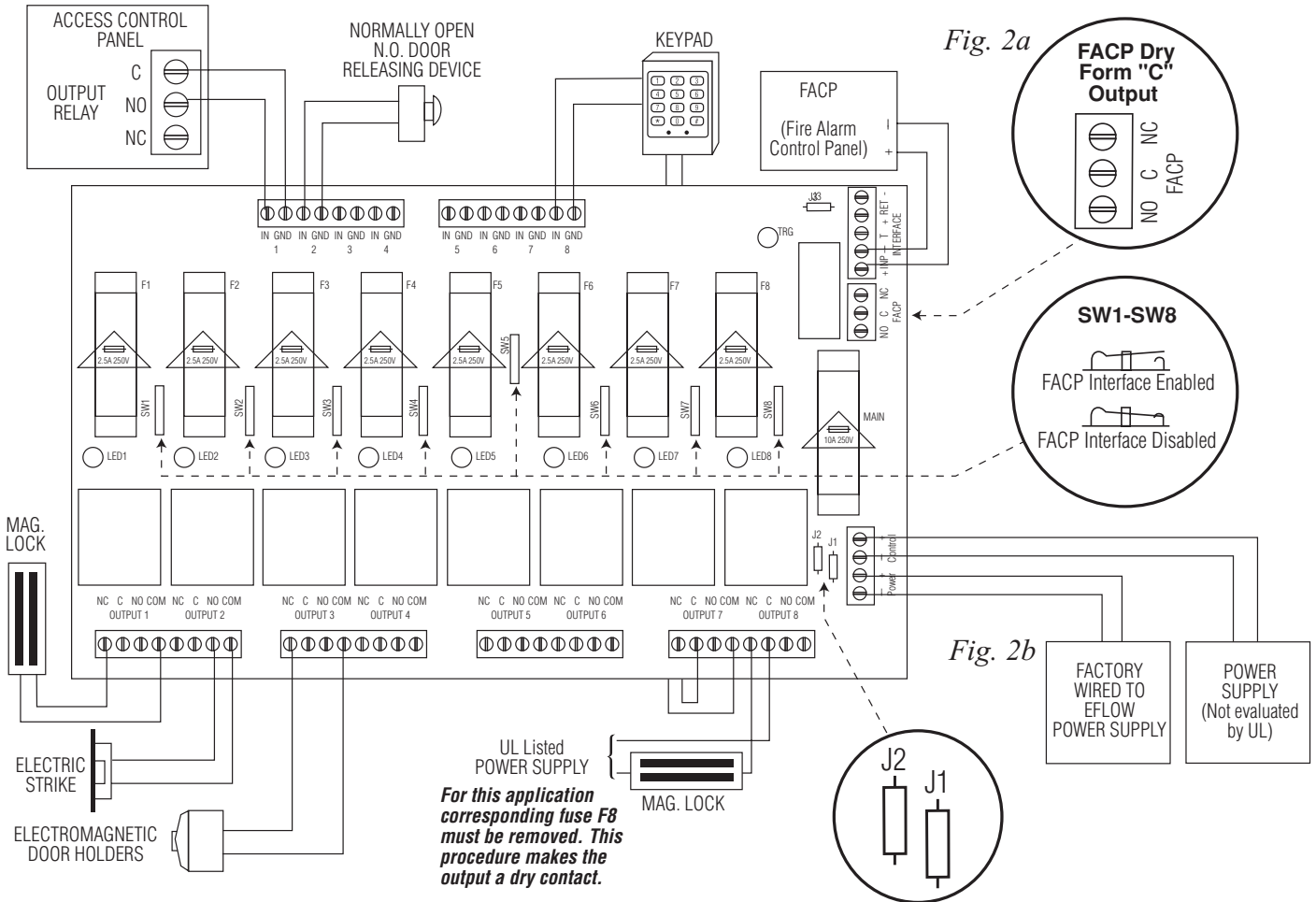

Fig. 2a

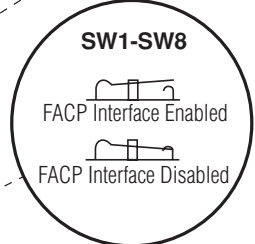
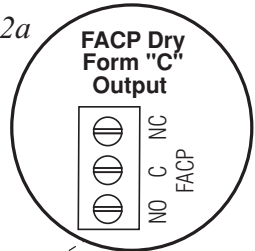
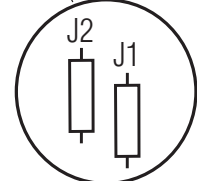

Fig. 2b





## NEC Power-Limited Wiring Requirements:

Power-limited and non power-limited circuit wiring must remain separated in the cabinet. All power-limited circuit wiring must remain at least 0.25" away from any non power-limited circuit wiring. Furthermore, all power-limited circuit wiring and non power-limited circuit wiring must enter and exit the cabinet through different conduits. One such example of this is shown below. Your specific application may require different conduit knockouts to be used. Any conduit knockouts may be used. For power-limited applications, use of conduit is optional. All field wiring connections must be made employing suitable gauge CM or FPL jacketed wire (or equivalent substitute).

Optional UL Listed battery enclosure must be mounted adjacent to the power supply via Class 1 wiring methods.

For Canadian installations use shielded wiring for all connections.

**Note:** Refer to wire handling drawing below for the proper way to install the CM or FPL jacketed wire, (Fig, 4a).

Fig. 4

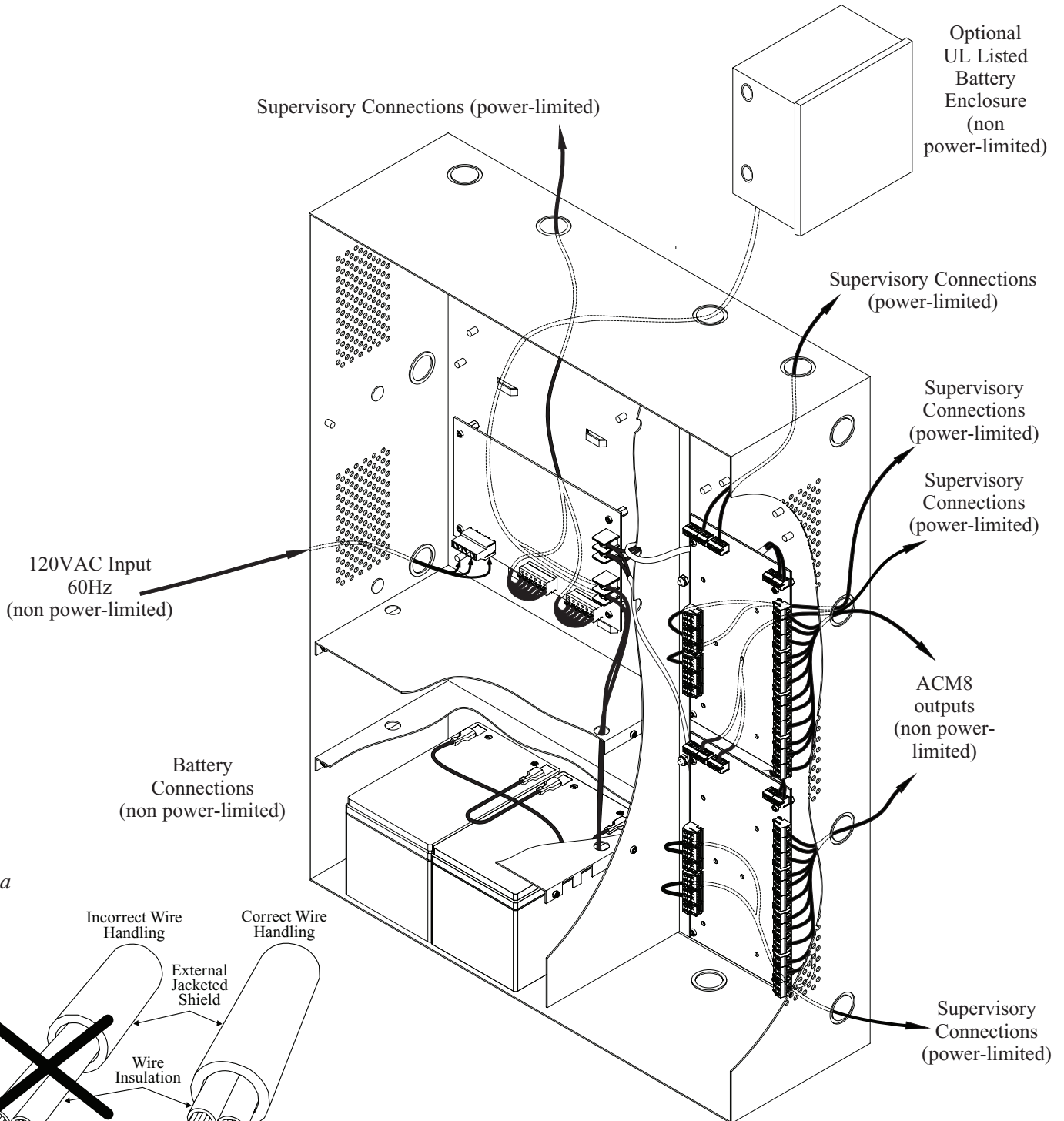
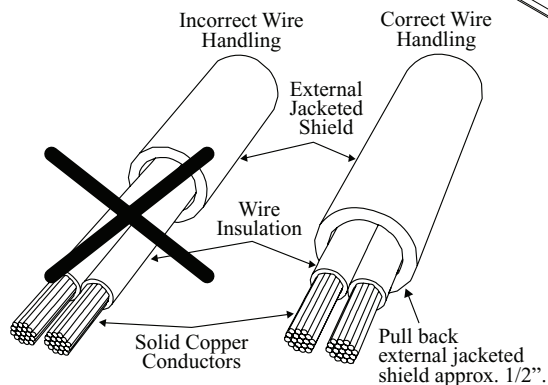

Fig. 4a





### FACP Hook-up Diagrams:

Fig. 5 Polarity reversal input from FACP signaling circuit output (polarity is referenced in alarm condition):

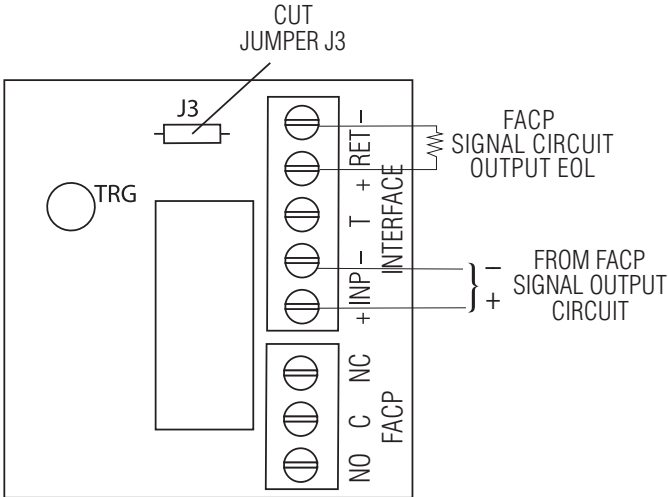

Fig. 6 Normally Open - Non-Latching FACP trigger input:

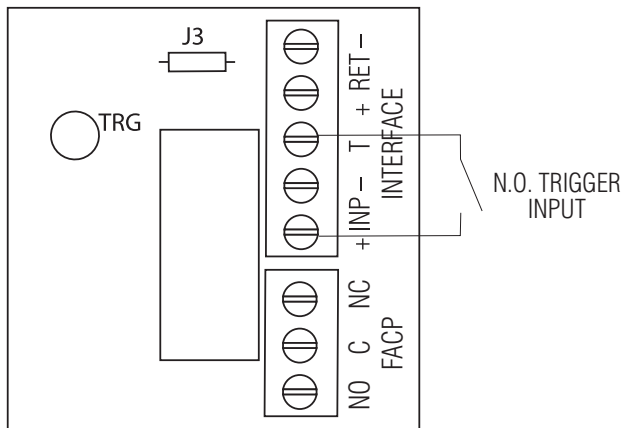

Fig. 7 Normally Open FACP Latching trigger input with reset: (This output has not been evaluated by UL)

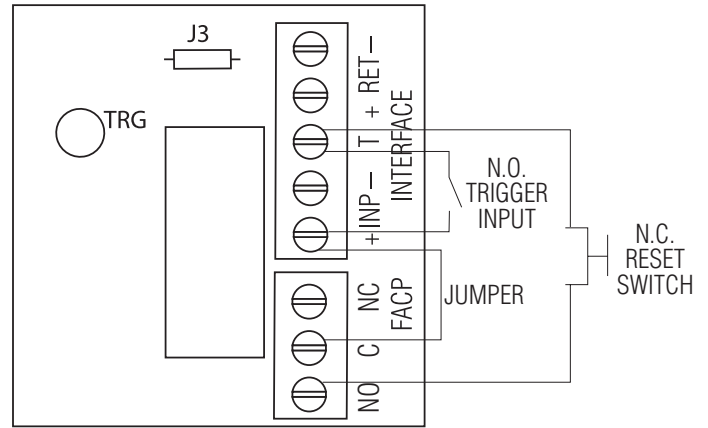

Fig. 8 Normally Closed - Non-Latching FACP trigger input:

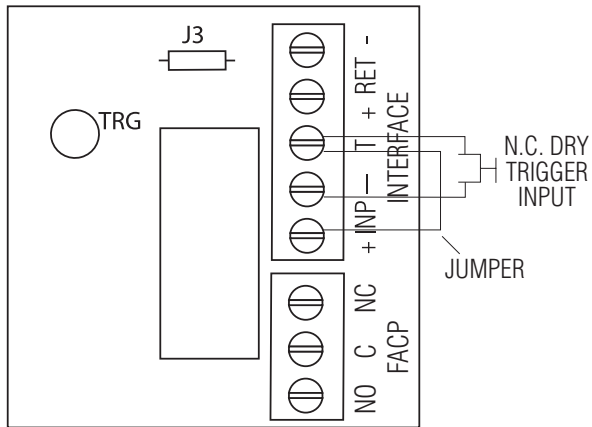
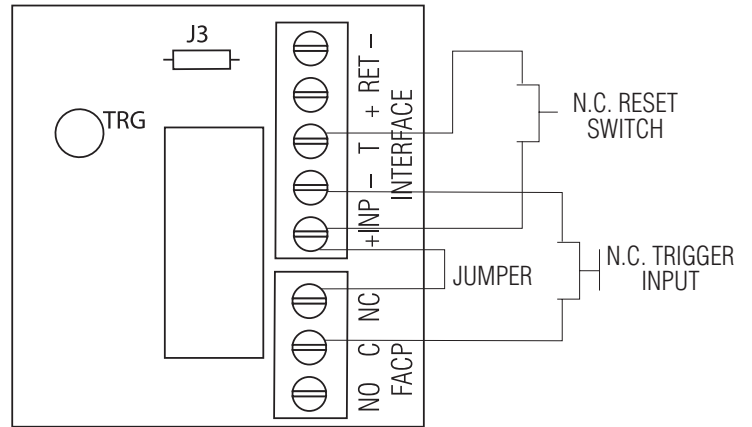

Fig. 9 Normally Closed - Latching FACP trigger input with reset: (This output has not been evaluated by UL)



**Notes:**

**Notes:**

**Enclosure Dimensions (H x W x D) (approximate):**

26" x 19" x 6.25" (660.4mm x 482.6mm x 158.75mm)

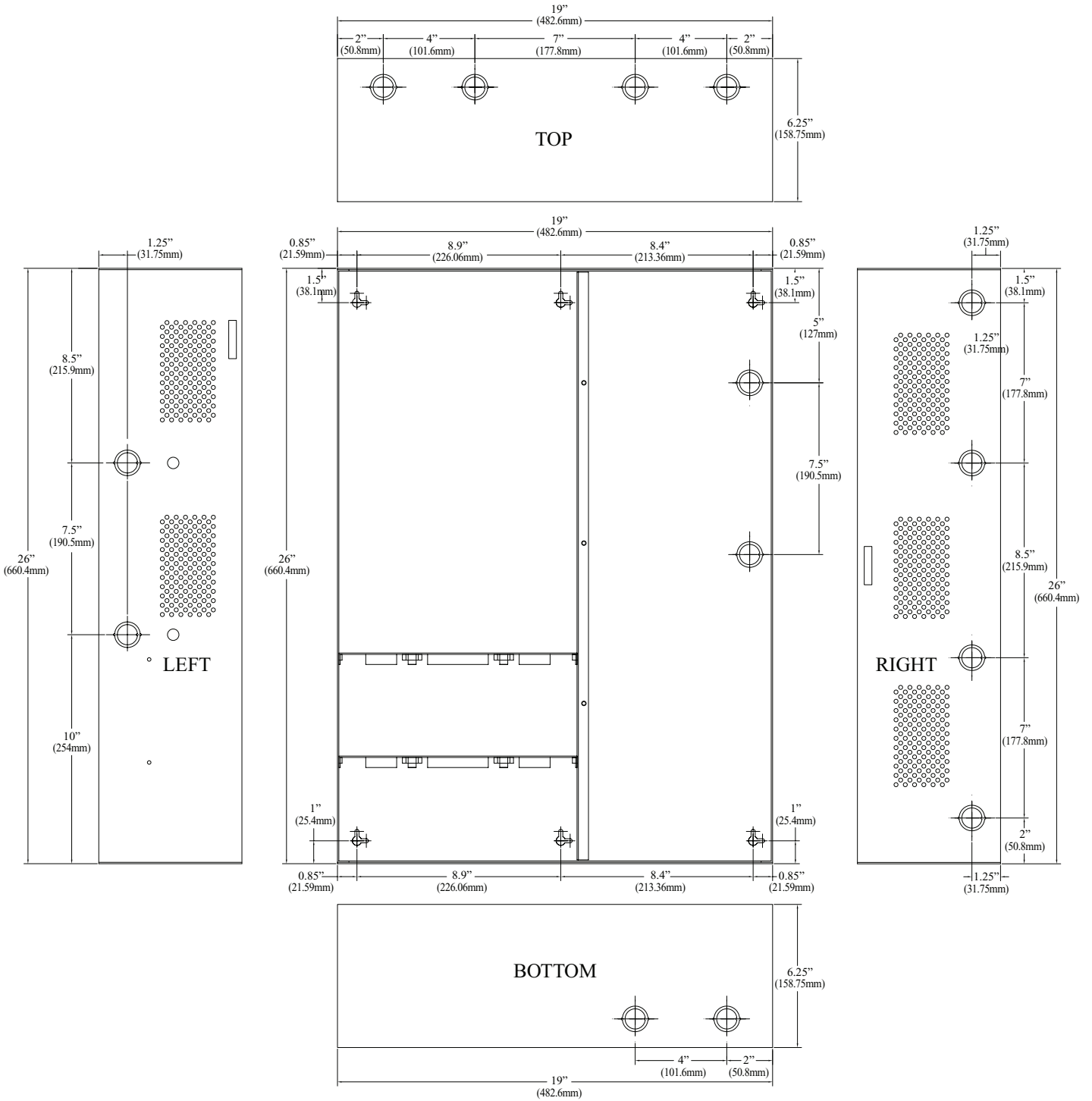

Altronix is not responsible for any typographical errors.

140 58th Street, Brooklyn, New York 11220 USA, 718-567-8181, fax: 718-567-9056  
 web site: [www.altronix.com](http://www.altronix.com), e-mail: [info@altronix.com](mailto:info@altronix.com), Lifetime Warranty, Made in U.S.A.  
 IIMaximal3F/5F/7F Series

F06N

