

# **MAXIMAL™ Series** **Expandable Power Systems**

## **Installation Guide**

### **Models Include:**

#### **Maximal11E**

- Power Supply 1:  
12VDC @ 4 amp or 24VDC @ 3 amp.
- Power Supply 2:  
12VDC @ 4 amp or 24VDC @ 3 amp.

#### **Maximal33E**

- Power Supply 1:  
12VDC or 24VDC @ 6 amp.
- Power Supply 2:  
12VDC or 24VDC @ 6 amp.

#### **Maximal37E**

- Power Supply 1:  
12VDC or 24VDC @ 6 amp.
- Power Supply 2:  
24VDC @ 10 amp.

#### **Maximal75E**

- Power Supply 1:  
24VDC @ 10 amp.
- Power Supply 2:  
12VDC @ 10 amp.

#### **Maximal13E**

- Power Supply 1:  
12VDC @ 4 amp or 24VDC @ 3 amp.
- Power Supply 2:  
12VDC or 24VDC @ 6 amp.

#### **Maximal35E**

- Power Supply 1:  
12VDC or 24VDC @ 6 amp.
- Power Supply 2:  
12VDC @ 10 amp.

#### **Maximal55E**

- Power Supply 1:  
12VDC @ 10 amp.
- Power Supply 2:  
12VDC @ 10 amp.

#### **Maximal77E**

- Power Supply 1:  
24VDC @ 10 amp.
- Power Supply 2:  
24VDC @ 10 amp.

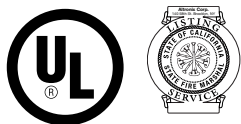

Rev. ME102512



**More than just power.™**



## **Table of Contents:**

MaximalE Overview.....	3
MaximalE Series Configuration Chart .....	3
MaximalE Features.....	3-4
MaximalE Installation Instructions .....	4
Maintenance.....	4
Power Supply Board Terminal Identification .....	5
Power Supply Board Stand-by Battery Specifications.....	5
Power Supply Board LED Diagnostics.....	6
Power Supply Board Output Voltage Settings.....	6
MaximalE Battery Hook-up Installation Instructions .....	7
NEC Power-Limited Wiring Requirements for Maximal11E.....	8
NEC Power-Limited Wiring Requirements for Maximal13E.....	9
NEC Power-Limited Wiring Requirements for Maximal33E, Maximal35E and Maximal55E.....	10
NEC Power-Limited Wiring Requirements for Maximal37E and Maximal75E.....	11
NEC Power-Limited Wiring Requirements for Maximal77E.....	12
Enclosure Dimensions .....	13

### Maximale Overview:

Maximal Expandable Power System provide system designers and installers with “maximum” power choices and the highest levels of versatility. They provide 12VDC, 24VDC, or 12VDC and 24VDC simultaneously via two (2) single output power supply/chargers. Includes AC fail, low battery and battery presence monitoring. Custom enclosure facilitates up to four (4) 12VDC/12AH batteries. All interconnecting equipment must be UL Listed.

### Maximale Series Configuration Chart:

Altronix Model Number	Output Voltage Options		Non Power-Limited Outputs	Class 2 Rated Power-Limited	115VAC 60 Hz Input (current)	Power Supply Board Input Fuse Rating	Power Supply Board Output Fuse Rating	Agency Listings and File Numbers
	Power Supply 1	Power Supply 2						
Maximal11E	AL400ULXB2	AL400ULXB2	-	2	7.0A	5A/250V	15A/32V	 California State Fire Marshal Approved    UL File # BP6714 UL 294 UL Listed for Access Control System Units.
	12VDC @ 4A	12VDC @ 4A						
	12VDC @ 4A	24VDC @ 3A						
	24VDC @ 3A	24VDC @ 3A						
Maximal13E	AL400ULXB2	AL600ULXB	1	1	7.0A	5A/250V	15A/32V (AL400ULXB2)	
	12VDC @ 4A	12VDC @ 6A						
	12VDC @ 4A	24VDC @ 6A						
	24VDC @ 3A	12VDC @ 6A						
	24VDC @ 3A	24VDC @ 6A						
Maximal33E	AL600ULXB	AL600ULXB	2	-	7.0A	5A/250V	-	
	12VDC @ 6A	12VDC @ 6A						
	12VDC @ 6A	24VDC @ 6A						
	24VDC @ 6A	24VDC @ 6A						
Maximal35E	AL600ULXB	AL1012ULXB	2	-	6.1A	5A/250V	15A/32V (AL1012ULXB)	
	12VDC @ 6A	12VDC @ 10A						
	24VDC @ 6A	12VDC @ 10A						
Maximal37E	AL600ULXB	AL1024ULXB2	2	-	7.9A	5A/250V (AL600ULXB and AL1024ULXB2)	15A/32V (AL1024ULXB2)	
	12VDC @ 6A	24VDC @ 10A						
	24VDC @ 6A	24VDC @ 10A						
Maximal55E	AL1012ULXB	AL1012ULXB	2	-	5.2A	5A/250V	15A/32V	
	12VDC @ 10A	12VDC @ 10A						
Maximal75E	AL1012ULXB	AL1024ULXB2	2	-	7.0A	5A/250V (AL1012ULXB and AL1024ULXB2)	15A/32V (AL1012ULXB and AL1024ULXB2)	
	12VDC @ 10A	24VDC @ 10A						
Maximal77E	AL1024ULXB2	AL1024ULXB2	2	-	8.8A	5A/250V	15A/32V	
	24VDC @ 10A	24VDC @ 10A						

### Maximale Features:

- Filtered and electronically regulated outputs (built-in power supply).
- Built-in charger for sealed lead acid or gel type batteries.
- AL400ULXB2, AL600ULXB and AL1012ULXB (Power Supply Board) maximum charge current 0.7 amp.
- AL1024ULXB2 (Power Supply Board) maximum charge current 3.6 amp.
- Automatic switch over to stand-by battery when AC fails.
- Zero voltage drop when unit switches over to battery backup (AC failure condition).
- Low battery and battery presence supervision (form “C” contact).

### **Maximale Features (cont'd):**

- Short circuit and thermal overload protection with auto reset.
- AC input and DC output LED indicators.
- AC fail supervision (form “C” contact).
- Enclosure accommodates up to four (4) 12VDC/12AH batteries.
- Enclosure dimensions: 26” (660.4mm) x 19” (482.6mm) x 6.25” (158.75mm)

### **Maximale Installation Instructions:**

Wiring methods shall be in accordance with the National Electrical Code/NFPA 70/ANSI, and with all local codes and authorities having jurisdiction. Product is intended for indoor use only.

**Power Supply Board Terminal Identification** (pg. 5)

**Power Supply Stand-by Battery Specifications** (pg. 5)

**Power Supply Board LED Diagnostics** (pg. 6)

**Power Supply Board Output Voltage Settings** (pg. 6)

1. Mount unit in desired location. Mark and predrill holes in the wall to line up with the top three keyholes in the enclosure. Install three upper fasteners and screws in the wall with the screw heads protruding. Place the enclosure’s upper keyholes over the three upper screws, level and secure. Mark the position of the lower three holes. Remove the enclosure. Drill the lower holes and install the three fasteners. Place the enclosure’s upper keyholes over the three upper screws. Install the three lower screws and make sure to tighten all screws (*Enclosure Dimensions, pg. 13*).
2. The power supply is pre-wired to the ground (chassis). Connect main incoming ground to the provided green grounding conductor lead. Connect unswitched AC power (115VAC 60Hz) to terminals marked [L, N] on both power supply boards. Use 14 AWG or larger for all power connections. (*Fig. 2, pg. 7*).  
**Keep power-limited wiring separate from non power-limited wiring. Minimum .25” spacing must be provided.**
3. Select desired DC output voltage by setting SW1 to the appropriate position, (Maximal11E, Maximal13E, Maximal33E, Maximal35E and Maximal37E) (*Fig. 1, pg. 6*). Maximal55E power supplies are factory set at 12VDC. Maximal77E power supplies are factory set at 24VDC. Maximal75E power supplies are factory set at 12VDC and 24VDC, (*Power Supply Board Stand-by Battery Specifications, pg. 5*).
4. Measure the output voltage of the unit before connecting any devices to ensure proper operation. Improper or high voltage will damage these devices.
5. Connect devices to be powered to terminals marked [+ DC -] (*Fig. 2, pg. 7*).
6. For Access Control applications, batteries are optional. When batteries are not used a loss of AC will result in the loss of output voltage. When the use of stand-by batteries is desired, they must be lead acid or gel type. Connect battery to terminals marked [+ BAT -] (*Figs. 2-7, pgs. 7-12*).  
Use two (2) 12VDC batteries connected in series for 24VDC operation (battery leads included).
7. Battery and AC Supervision outputs: It is required to connect supervisory trouble reporting devices to outputs marked [AC Fail, BAT FAIL] supervisory relay outputs marked [NC, C, NO] to appropriate visual notification devices. Use 22 AWG to 18 AWG for AC Fail & Low/No Battery reporting (*Fig. 2a, pgs. 7*).
8. Mount UL Listed tamper switch (Not Included) (Sentrol model 3012 or equivalent) at the top of the enclosure. Slide the tamper switch bracket onto the edge of the enclosure approximately 2” from the right side (*Fig. 2b, pg. 7*). Connect tamper switch wiring to the Access Control Panel input or the appropriate UL Listed reporting device. To activate alarm signal open the door of the enclosure.
9. Please insure that the cover is secured with the provided key lock.

### **Maintenance:**

Unit should be tested at least once a year for the proper operation as follows:

**Output Voltage Test:** Under normal load conditions, the DC output voltage should be checked for proper voltage level (*Power Supply Stand-by Battery Specifications, pg. 5*).

**Battery Test:** Under normal load conditions check that the battery is fully charged, check specified voltage at the battery terminals and at the board terminals marked [+ BAT -] to insure that there is no break in the battery connection wires.

**Note:** AL400ULXB2, AL600ULXB and AL1012ULXB (Power Supply Board) maximum charge current is 0.7 amp. AL1024ULXB2 (Power Supply Board) maximum charge current is 3.6 amp.

Expected battery life is 5 years, however it is recommended to change batteries within 4 years or less if necessary.

### **Power Supply Board Terminal Identification:**

<b>Terminal Legend</b>	<b>Function/Description</b>
L, G, N	Connect 115VAC 60Hz to these terminals: L to hot, N to neutral.
+ DC –	<i>Refer to Maximal Series Configuration Chart, pg. 3.</i>
AC FAIL NC, C, NO	Indicates loss of AC power. To meet with UL requirements it is mandatory to connect visual notification devices, connecting audible notification devices is optional. Relay normally energized when AC power is present. Contact rating 1 amp @ 28VDC. AC or brownout fail is reported within 1 minute of event.
BAT FAIL NC, C, NO	Indicates low battery condition, e.g. connect to alarm panel. Relay normally energized when DC power is present. Contact rating 1 amp @ 28VDC. A removed battery is reported within 5 minutes. Battery reconnection is reported within 1 minute. Low battery threshold: 12VDC output threshold set @ approximately 10.5VDC. 24VDC output threshold set @ approximately 21VDC.
+ BAT -	Stand-by battery connections. AL400ULXB2, AL600ULXB and AL1012ULXB (Power Supply Board) maximum charge current is 0.7 amp. AL1024ULXB2 (Power Supply Board) maximum charge current is 3.6 amp.

### **Power Supply Board Stand-by Battery Specifications**

<b>Altronix Model</b>	<b>Power Supply Board</b>	<b>Battery</b>	<b>20 min. of Backup</b>	<b>4 hr. of Backup</b>	<b>24 hr. of Backup</b>	<b>60 hr. of Backup</b>
<b>Maximal11E</b> <b>Maximal13E</b>	AL400ULXB2 <i>(Refer to Fig. 1a, 1b on pg. 6 for Switch [SW1] location and position)</i>	12VDC/40AH*	N/A	4 amp	1 amp	300mA
		24VDC/12AH	N/A	200mA	N/A	N/A
		24VDC/40AH*	N/A	3 amp	1 amp	300mA
<b>Maximal13E</b> <b>Maximal33E</b> <b>Maximal35E</b> <b>Maximal37E</b>	AL600ULXB <i>(Refer to Fig. 1a, 1b on pg. 6 for Switch [SW1] location and position)</i>	12VDC/40AH*	N/A	6 amp	1 amp	300mA
		24VDC/12AH	N/A	200mA	N/A	N/A
		24VDC/40AH*	N/A	6 amp	1 amp	300mA
<b>Maximal35E</b> <b>Maximal55E</b> <b>Maximal75E</b>	AL1012ULXB <i>(Factory set at 12VDC)</i>	12VDC/12AH	10 amp	Battery capacity for emergency stand-by at least 20 mins.	N/A	N/A
<b>Maximal37E</b> <b>Maximal75E</b> <b>Maximal77E</b>	AL1024ULXB2 <i>(Factory set at 24VDC)</i>	24VDC/12AH	8 amp	1.5 amp	200mA	100mA
		24VDC/65AH*	N/A	8 amp	1.5 amp	500mA

\* **Note:** Additional battery enclosure required (Figs. 3-5, pgs, 8-10).

**Power Supply Board LED Diagnostics:**

LED		Power Supply Status
Red (DC)	Green (AC)	
ON	ON	Normal operating condition.
ON	OFF	Loss of AC, Stand-by battery supplying power.
OFF	ON	No DC output. Short circuit or thermal overload condition.
OFF	OFF	No DC output. Loss of AC. Discharged battery.

Red (Bat)	Battery Status
ON	Normal operating condition.
OFF	Battery fail/low battery.

**Power Supply Board Output Voltage Settings:**

Fig. 1

Fig. 1a  
AL400ULXB2 / AL600ULXB Power Supply Board

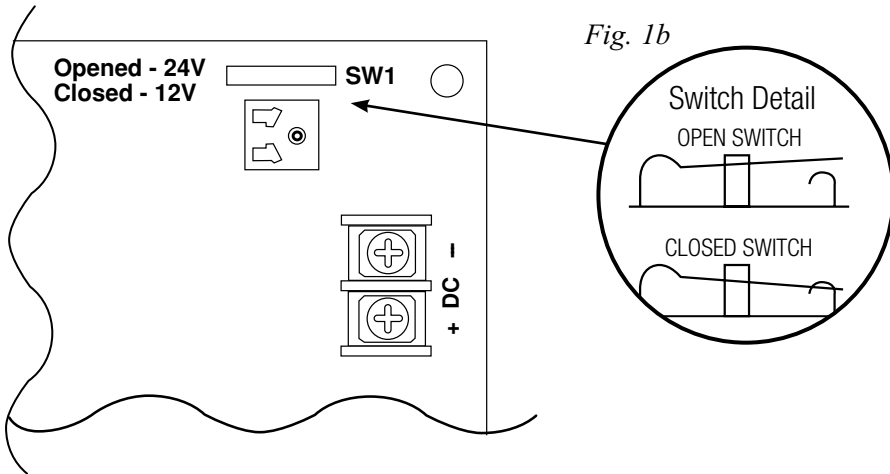
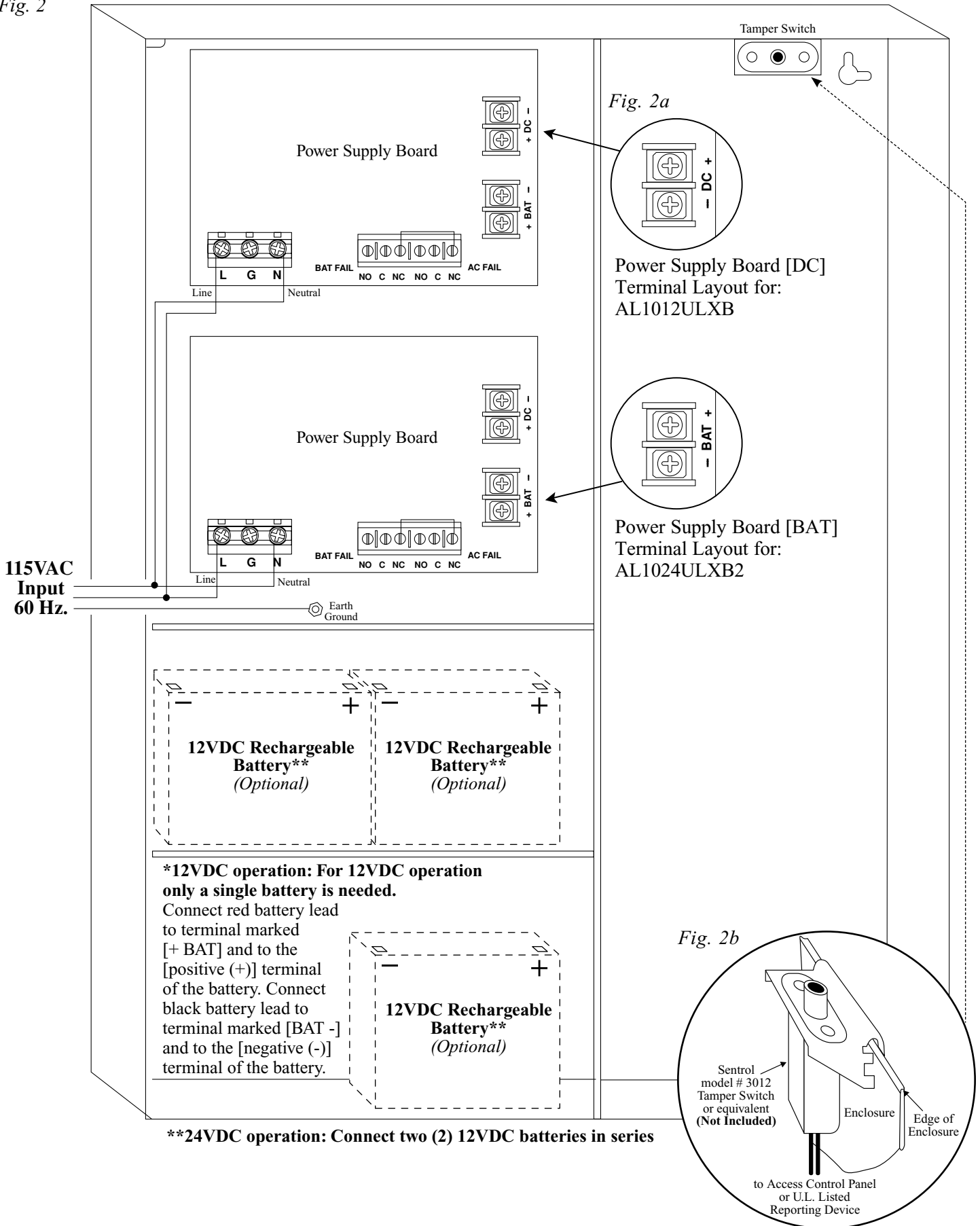

Fig. 2



### NEC Power-Limited Wiring Requirements for Maximal11E:

Power-limited and non power-limited circuit wiring must remain separated in the cabinet. All power-limited circuit wiring must remain at least 0.25" away from any non power-limited circuit wiring. Furthermore, all power-limited circuit wiring and non power-limited circuit wiring must enter and exit the cabinet through different conduits. One such example of this is shown below. Your specific application may require different conduit knockouts to be used. Any conduit knockouts may be used. For power-limited applications, use of conduit is optional.

All field wiring connections must be made employing suitable gauge CM or FPL jacketed wire (or equivalent substitute).

**Note:** Refer to wire handling drawing below for the proper way to install the CM or FPL jacketed wire, (Fig. 3a).

Fig. 3

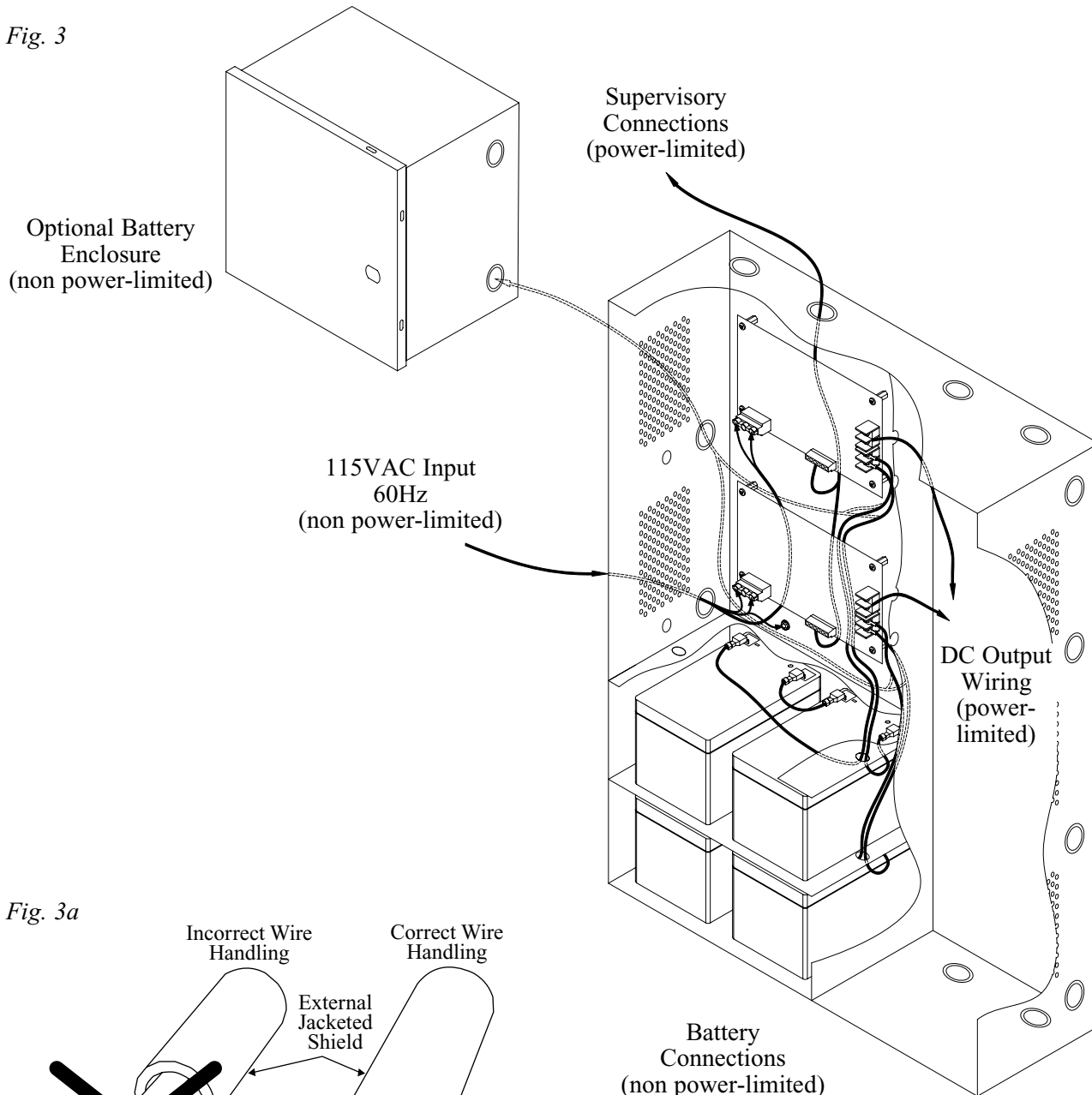
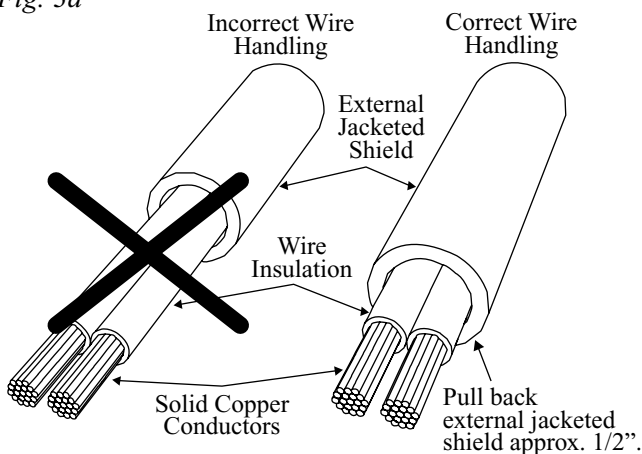

Fig. 3a





### NEC Power-Limited Wiring Requirements for Maximal13E:

Power-limited and non power-limited circuit wiring must remain separated in the cabinet. All power-limited circuit wiring must remain at least 0.25" away from any non power-limited circuit wiring. Furthermore, all power-limited circuit wiring and non power-limited circuit wiring must enter and exit the cabinet through different conduits. One such example of this is shown below. Your specific application may require different conduit knockouts to be used. Any conduit knockouts may be used. For power-limited applications, use of conduit is optional.

All field wiring connections must be made employing suitable gauge CM or FPL jacketed wire (or equivalent substitute).

**Note:** Refer to wire handling drawing below for the proper way to install the CM or FPL jacketed wire, (Fig. 4a).

Fig. 4

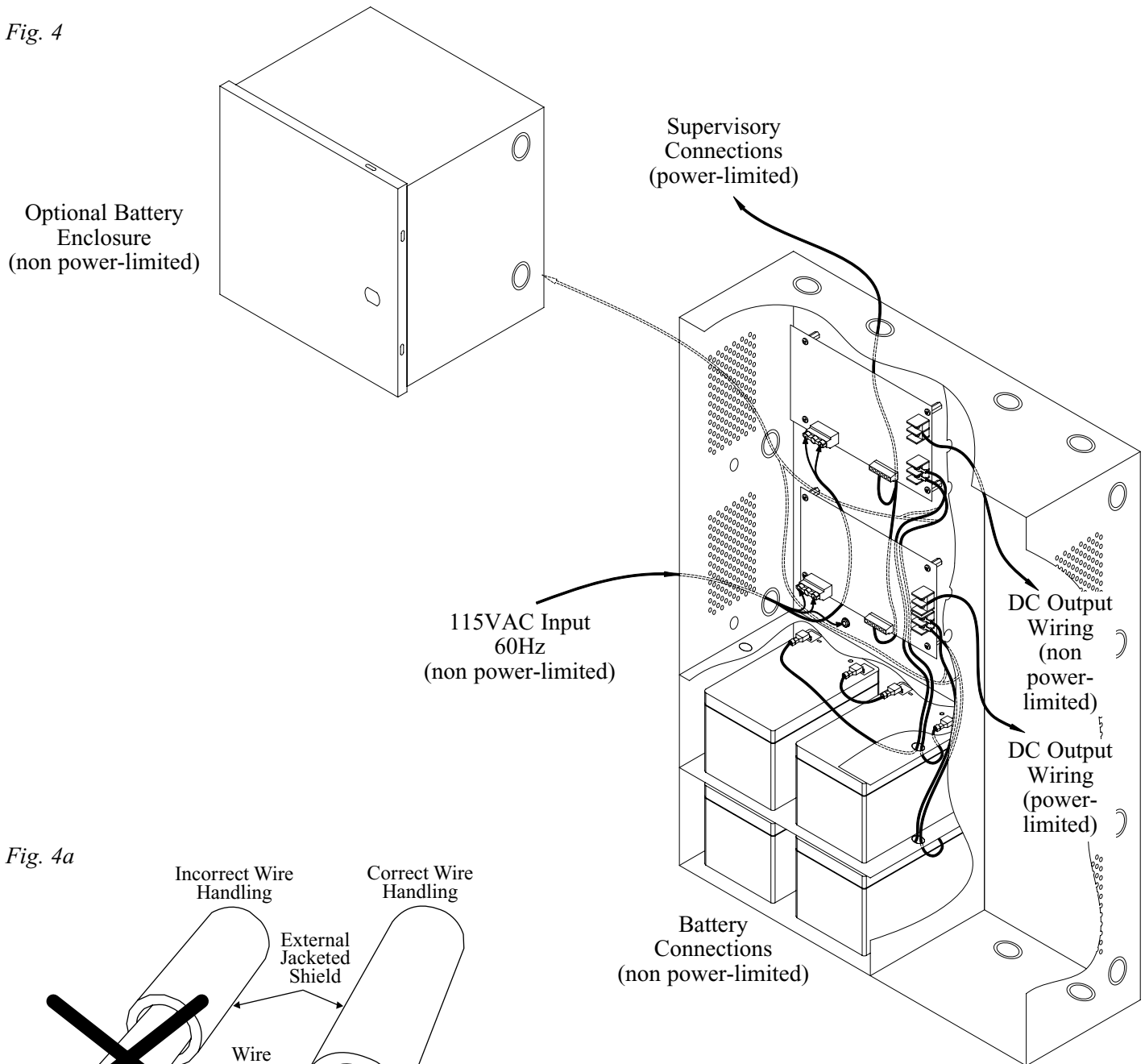
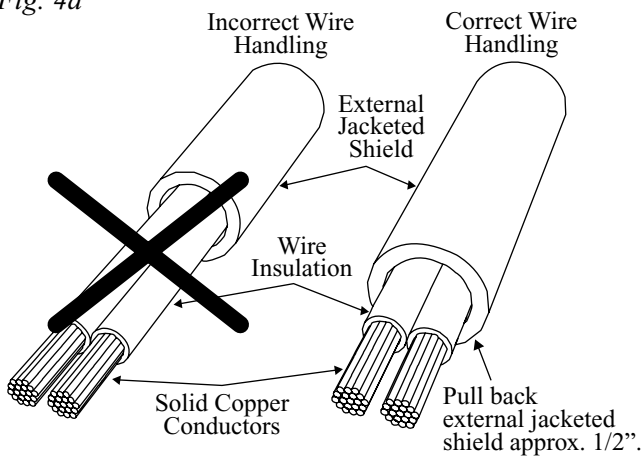

Fig. 4a



**NEC Power-Limited Wiring Requirements for Maximal33E, Maximal35E and Maximal55E:**

Power-limited and non power-limited circuit wiring must remain separated in the cabinet. All power-limited circuit wiring must remain at least 0.25” away from any non power-limited circuit wiring. Furthermore, all power-limited circuit wiring and non power-limited circuit wiring must enter and exit the cabinet through different conduits. One such example of this is shown below. Your specific application may require different conduit knockouts to be used. Any conduit knockouts may be used. For power-limited applications, use of conduit is optional.

All field wiring connections must be made employing suitable gauge CM or FPL jacketed wire (or equivalent substitute).

**Note:** Refer to wire handling drawing below for the proper way to install the CM or FPL jacketed wire, (Fig. 5a).

Fig. 5

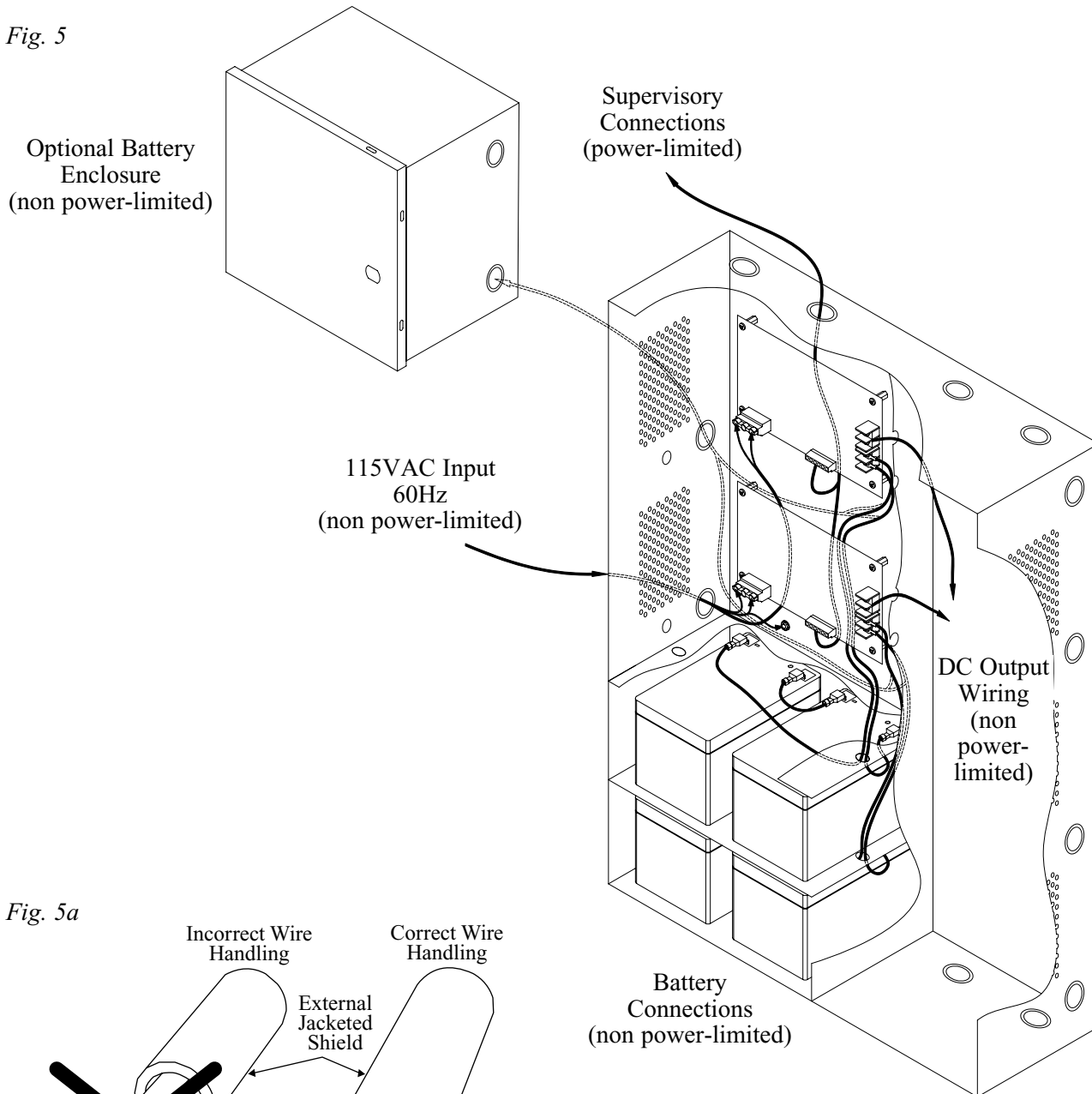
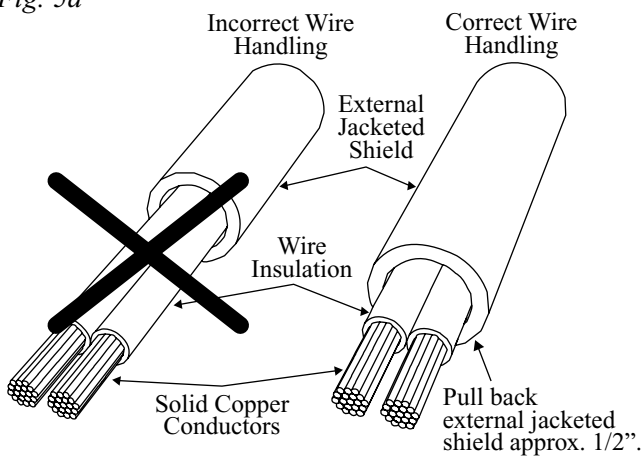

Fig. 5a



### NEC Power-Limited Wiring Requirements for Maximal37E and Maximal75E:

Power-limited and non power-limited circuit wiring must remain separated in the cabinet. All power-limited circuit wiring must remain at least 0.25" away from any non power-limited circuit wiring. Furthermore, all power-limited circuit wiring and non power-limited circuit wiring must enter and exit the cabinet through different conduits. One such example of this is shown below. Your specific application may require different conduit knockouts to be used. Any conduit knockouts may be used. For power-limited applications, use of conduit is optional.

All field wiring connections must be made employing suitable gauge CM or FPL jacketed wire (or equivalent substitute).

**Note:** Refer to wire handling drawing below for the proper way to install the CM or FPL jacketed wire, (Fig. 6a).

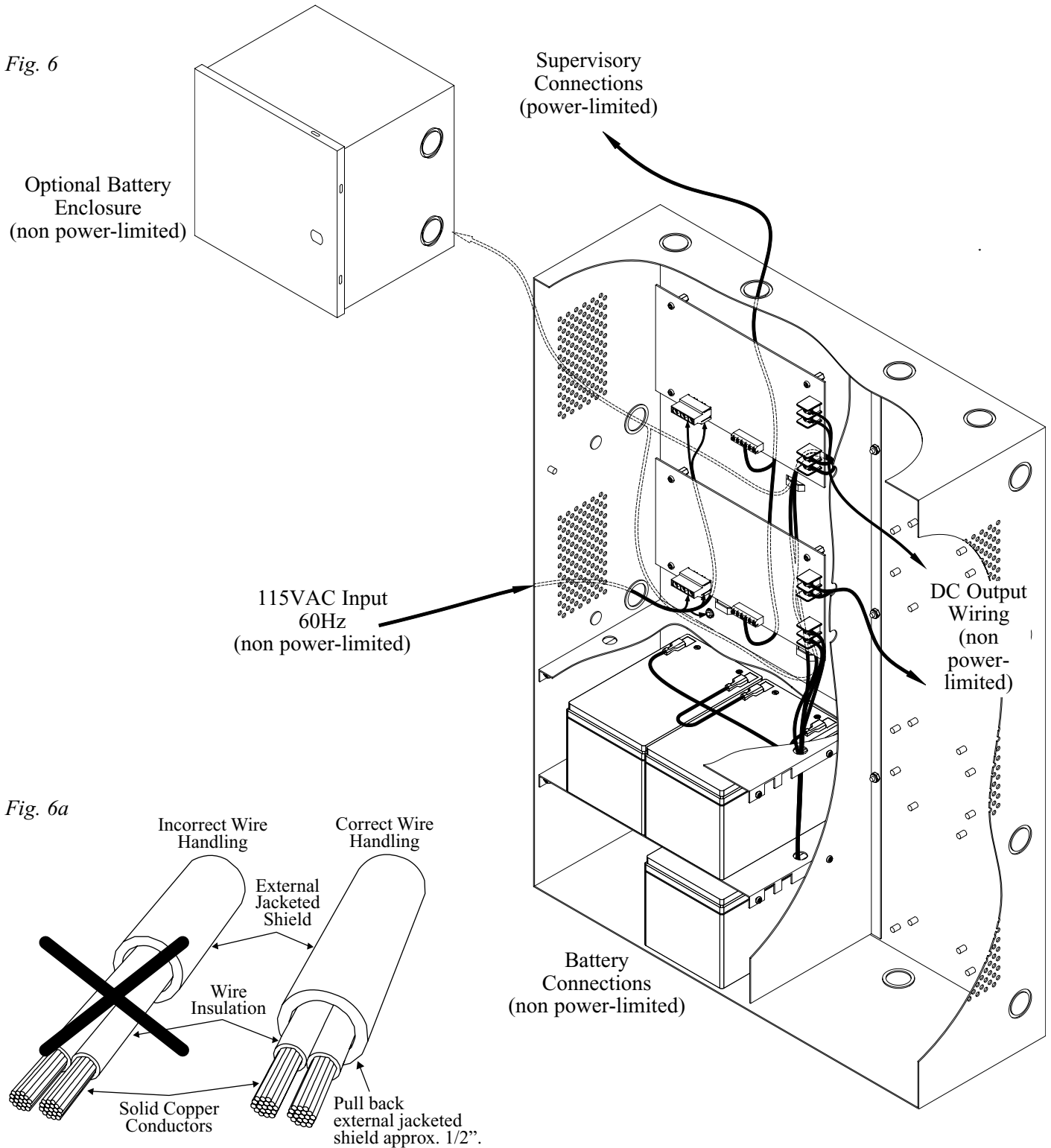

## NEC Power-Limited Wiring Requirements for Maximal77E:

Power-limited and non power-limited circuit wiring must remain separated in the cabinet. All power-limited circuit wiring must remain at least 0.25" away from any non power-limited circuit wiring. Furthermore, all power-limited circuit wiring and non power-limited circuit wiring must enter and exit the cabinet through different conduits. One such example of this is shown below. Your specific application may require different conduit knockouts to be used. Any conduit knockouts may be used. For power-limited applications, use of conduit is optional.

All field wiring connections must be made employing suitable gauge CM or FPL jacketed wire (or equivalent substitute).

**Note:** Refer to wire handling drawing below for the proper way to install the CM or FPL jacketed wire, (Fig. 7a).

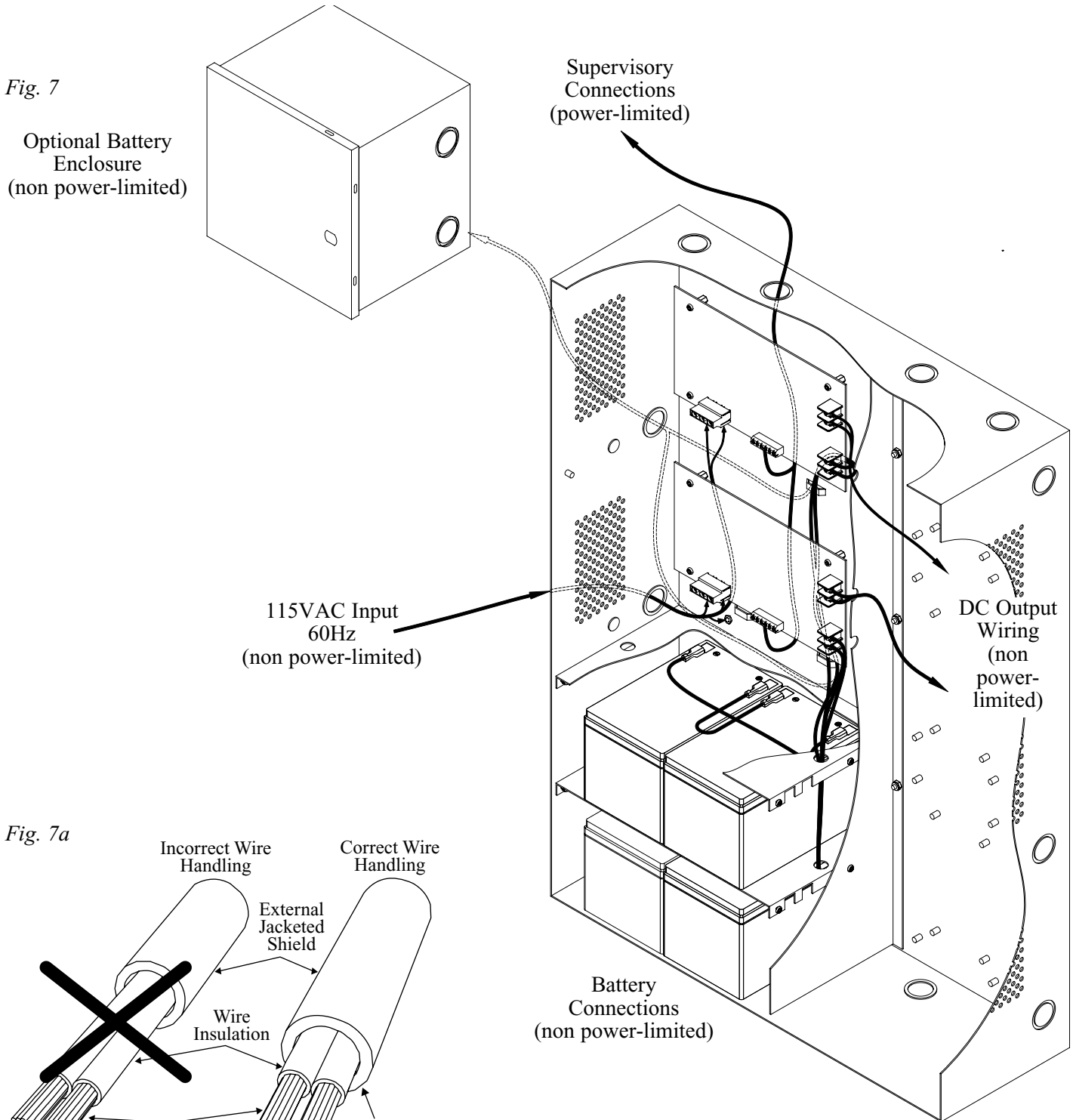
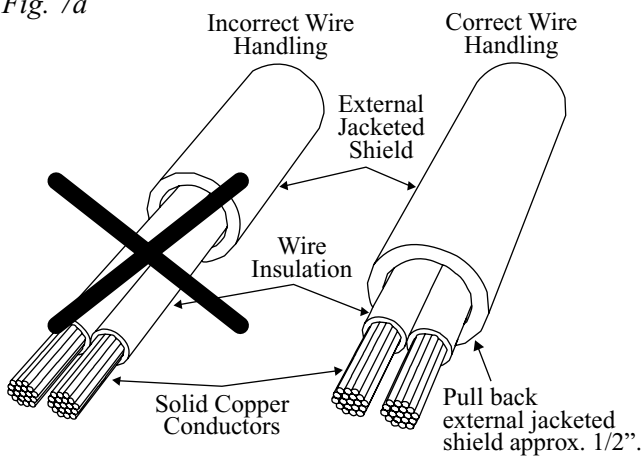
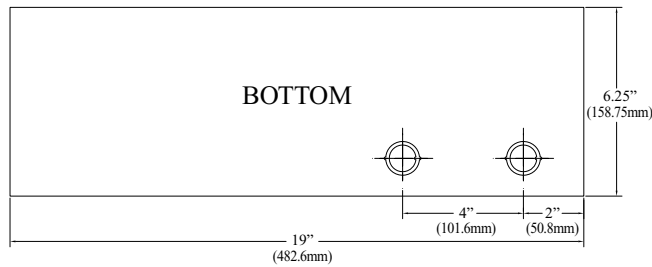
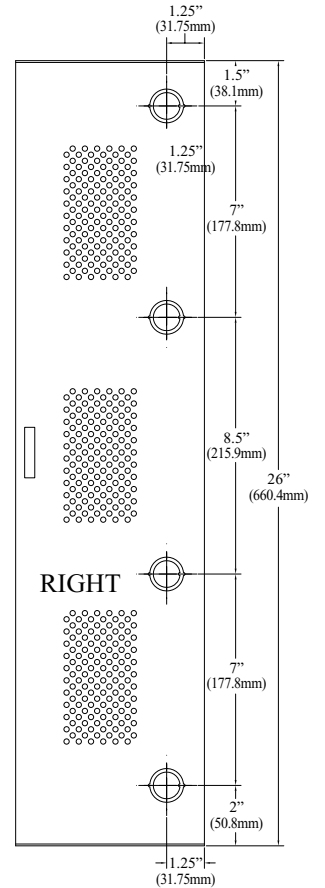
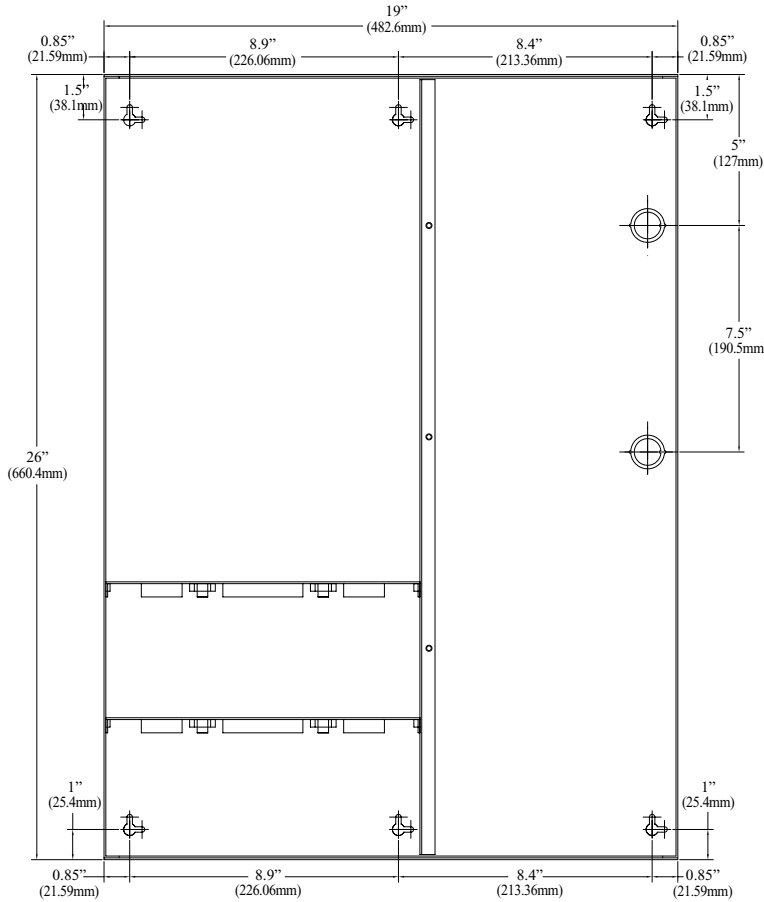
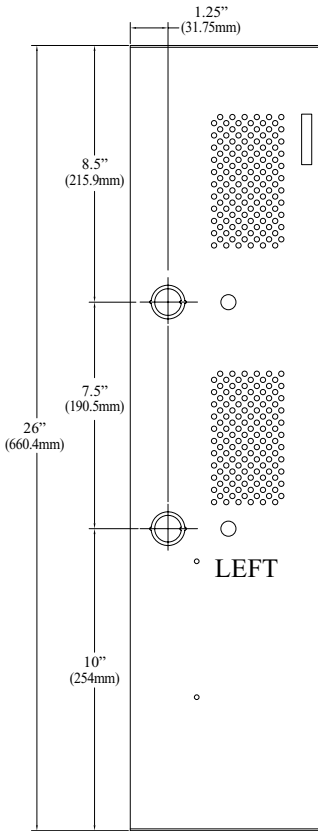
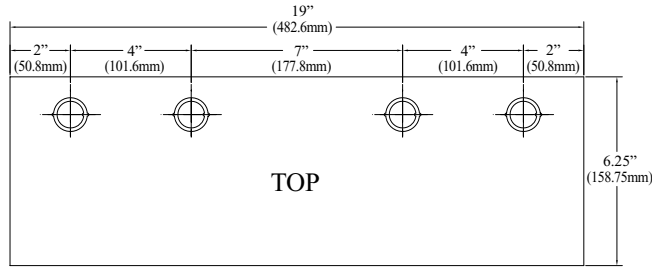

Fig. 7a



**Enclosure Dimensions (H x W x D) (approximate):**

26" (660.4mm) x 19" (482.6mm) x 6.25" (158.75mm)



**Notes:**

**Notes:**

## **Notes:**

Altronix is not responsible for any typographical errors.

---

140 58th Street, Brooklyn, New York 11220 USA, 718-567-8181, fax: 718-567-9056  
web site: [www.altronix.com](http://www.altronix.com), e-mail: [info@altronix.com](mailto:info@altronix.com), Lifetime Warranty, Made in U.S.A.  
II MaximalE Series B25M

