

# MAXIMAL™

## ***Rack Mount Series***

## ***Installation Guide***

### ***Models Include:***

#### ***Maximal1RHDV***

- 12VDC @ 4 amp or 24VDC @ 3 amp.
- Eight (8) PTC Protected Outputs.

#### ***Maximal3RHDV***

- 12VDC or 24VDC @ 6 amp.
- Eight (8) PTC Protected Outputs.

#### ***Maximal33RDV***

- 12VDC and/or 24VDC @ 12 amp.
- Sixteen (16) PTC Protected Outputs.

#### ***Maximal1RDV***

- 12VDC @ 4 amp or 24VDC @ 3 amp.
- Sixteen (16) PTC Protected Outputs.

#### ***Maximal3RDV***

- 12VDC or 24VDC @ 6 amp.
- Sixteen (16) PTC Protected Outputs.



## **Table of Contents:**

MaximalRDV Rack Mount Series Overview.....	3
MaximalRDV Rack Mount Series Configuration Chart.....	3
MaximalRDV Rack Mount Series Specifications.....	3
Installation Instructions .....	4
Maintenance.....	5
Fire Alarm Interface Switch Settings .....	5
Output Voltage and Stand-by Specification Charts .....	5
LED Diagnostics.....	5
Power Supply Board Output Voltage Settings .....	6
Fire Alarm Interface, Output Selection and Input Type .....	6
Power Supply Board Drawings .....	8
FACP Hook-up Diagrams .....	9
Mounting Bracket Diagrams .....	10
Rack Mechanical Drawing and Dimensions .....	11

## **Overview:**

Maximal Rack Mount Series units distribute and switch power to access control systems and accessories. They convert a 220VAC 50/60Hz input into eight (8) or sixteen (16) independently controlled 12VDC and/or 24VDC PTC protected outputs. Outputs are activated by a normally open (NO) or normally closed (NC) dry trigger input from an Access Control System, Card Reader, Keypad, Push Button, PIR, etc. Units will route power to a variety of access control hardware devices including: Mag Locks, Electric Strikes, Magnetic Door Holders, etc. Outputs will operate in both Fail-Safe and/or Fail-Secure modes. The FACP Interface enables Emergency Egress, Alarm Monitoring, or may be used to trigger other auxiliary devices. The fire alarm disconnect feature is individually selectable for any or all of the outputs (see chart below).

### **Maximal Rack Mount Series Configuration Chart:**

Altronix Model Number	Power Supply 1 (8 outputs)	Power Supply 2 (8 outputs)	Total Output Current	Fuse Protected Outputs	Maximum Current Per ACM8R-M Output	220VAC 50/60Hz Input (current draw)	Power Supply Board Input Fuse Rating
<b>Maximal1RHDV</b>	12VDC @ 4 amp	N/A	4 amp	8	2.0 amp	0.9 amp	5A/250V
	24VDC @ 3 amp	N/A	3 amp				
<b>Maximal1RDV</b>	12VDC @ 4 amp	N/A	4 amp	16	2.0 amp	0.9 amp	5A/250V
	24VDC @ 3 amp	N/A	3 amp				
<b>Maximal3RHDV</b>	12VDC @ 6 amp	N/A	6 amp	8	2.0 amp	0.9 amp	3.5A/250V
	24VDC @ 6 amp	N/A					
<b>Maximal3RDV</b>	12VDC @ 6 amp	N/A	6 amp	16	2.0 amp	0.9 amp	3.5A/250V
	24VDC @ 6 amp	N/A					
<b>Maximal33RDV</b>	12VDC @ 6 amp	12VDC @ 6 amp	12 amp	16	2.0 amp	1.9 amp	3.5A/250V
	24VDC @ 6 amp	24VDC @ 6 amp					
	12VDC @ 6 amp	24VDC @ 6 amp					

## **Specifications:**

### **Inputs:**

- Normally closed [NC] or normally open [NO] dry contact inputs (switch selectable).

### **Outputs:**

- Individually selectable Mag Lock/Strike (Fail-Safe, Fail-Secure) PTC protected power outputs.
- Thermal and short circuit protection with auto reset.

### **Fire Alarm Interface:**

- Fire Alarm disconnect (latching with reset or non-latching) is individually selectable for any or all of the outputs.
- Remote reset capability for latching Fire Alarm Interface mode.
- Fire Alarm disconnect input options:
  - a) Normally open [NO] or normally closed [NC] dry contact input.
  - b) Polarity reversal input from FACP signaling circuit.

### **Visual Indicators:**

- Individual Output Status LEDs located on the front panel.

### **Battery Backup:**

- Built-in charger for sealed lead acid or gel type batteries (A separate enclosure is required for batteries).
- Maximum charge current 0.7 amp.
- Automatic switch over to stand-by battery when AC fails.
- Zero voltage drop when unit switches over to battery backup (AC failure condition).

### **Supervision:**

- AC fail supervision (form "C" contact).
- Low battery supervision (form "C" contact).

### **Additional Features:**

- Removable terminal blocks with locking screw flange.
- 3-wire line cord.
- Illuminated master power disconnect circuit breaker with manual reset.

### **Rack Dimensions (H x W x D):**

3.25" x 19.125" x 8.5"  
(82.55mm x 485.78mm x 215.9mm)

## **Installation Instructions:**

**Important:** Adjust output voltages and Fire Alarm Interface configuration before installing unit in the rack.

1. Separate bottom and top of the rack mount chassis by removing six (6) screws (*Rack Mechanical Drawing & Dimensions, pg. 11*).  
**CAUTION: Do not touch exposed metal parts. Shut branch circuit power before installing or servicing equipment. There are no user serviceable parts inside. Refer installation and servicing to qualified service personnel.**
2. **Set output voltage:**  
Select desired DC output voltage by setting SW1 on the power supply board(s) (*Fig. 1a, pg. 6*) to the appropriate position (*Output Voltage and Stand-by Specification Charts, pg. 5*).  
For Maximal33RDV each set of eight (8) outputs can be set for 12VDC or 24VDC (example: eight (8) outputs @ 12VDC and eight (8) outputs @ 24VDC).
3. **Input trigger programming options:**  
The unit can be programmed to operate with either a normally open or normally closed input from access control devices by setting switches SW3 on either the ACM8R-S or ACM16R-S board to the appropriate position (*Fig. 2b, pg. 6*); OPEN for a normally closed [NC] trigger input or CLOSED for a normally open [NO] input.
4. **Output programming options:**
  - a. The outputs can be programmed to be either all Fail-Safe (i.e. mag locks), all Fail-Secure (i.e. electric strikes) or any combination of each by setting the corresponding OUTPUT SELECT dip switches (1-8) on the ACM8R-S board to the appropriate position; ON for Fail-Safe outputs or OFF for Fail-Secure outputs (*Fig. 2a, pg. 6*).  
**Note:** the output configuration will follow the input trigger option
  - b. To enable the FACP Disconnect for an output the corresponding FIRE ALARM INTERFACE switch must be in the ON position. To disable the FACP Disconnect the FIRE ALARM INTERFACE dip switches (1-8) on the ACM8R-S/ACM16R-S board must be in the OFF position (*Fig. 2a, pg. 6*).
5. **Fire Alarm Interface hookup options:**  
A normally closed [NC], normally open [NO] input or polarity reversal from an FACP signaling circuit will trigger the selected outputs (*Figs. 5-10, pg. 9*). To program the Fire Alarm Interface set dip switches SW1 and SW2 on the ACM8R-M board to the appropriate positions (*Figs. 3a & 3b, pg. 7*) (*Fire Alarm Interface Switch Settings pg. 5*).
6. **Battery Connections:**  
For access control applications batteries are optional. If batteries are not used, a loss of AC will result in the loss of output voltage. When batteries are used, they must be lead acid or gel type. Connect one (1) battery to the terminals marked [- BAT +] for 12VDC operation. Use two (2) 12VDC batteries wired in series for 24VDC operation (*Fig. 4b, pg. 8*). The rack mount enclosure will not accommodate batteries. A separate battery enclosure is required.  
**Note:** When using the Maximal33RDV with battery backup, two (2) separate batteries or sets of batteries must be used.
7. **Battery and AC Supervision outputs:**  
Connect the appropriate notification signaling device to the terminals marked AC Fail and Battery Fail on the power supply board(s) (*Fig. 4a, pg. 8*). Use 22AWG to 18AWG for AC Fail and Low/No Battery reporting.
8. Reassemble the bottom and top of rack mount chassis by fastening the six (6) screws.  
(*Rack Mechanical Drawing & Dimensions pg. 11*).
9. Attach mounting brackets to rack mount Maximal for desired rack or wall installation (*Fig. 11-13, pg. 10*).
10. Mount in the desired rack location. Do not obstruct side air vents.
11. Set the power disconnect circuit breaker to the OFF position (*Fig. 14a, pg. 11*).
12. Plug power cord into a grounded 220VAC 50/60Hz receptacle (*Fig. 14b, pg. 11*).
13. Set the power disconnect circuit breaker to the ON position (*Fig. 14a, pg. 11*).
14. Measure the output voltage before connecting devices. This helps avoiding potential damage.
15. Set the power disconnect circuit breaker to the OFF position (*Fig. 14a, pg. 11*).
16. **Input trigger connections:**  
Connect the Normally Open or Normally Closed input triggers from the access control devices to the removable terminals marked [IN1 and GND] through [IN8 and GND] for Maximal1RHVDV and Maximal3RHVDV.  
For Maximal1RDV, Maximal3RDV and Maximal33RDV connect devices to the second set of terminals as well. Make sure the devices match settings of SW3 in step 3 (*Rack Mechanical Drawing & Dimensions pg. 11*).
17. **Output connections:**  
Connect the devices to be powered to the removable terminals marked [-- OUT1 + to -- OUT8 +] for Maximal1RHVDV and Maximal3RHVDV. For Maximal1RDV, Maximal3RDV and Maximal33RDV connect devices to the second set of terminals marked [- OUT1 + to - OUT8 +] (*Fig. 14c, pg. 11*).
18. **Fire Alarm Interface connection options:**
  - a. Connect the FACP trigger input to the removable terminals marked FACP1 and FACP2. When using the polarity reversal from an FACP signaling circuit, connect the negative [-] to the terminal marked FACP1 and the positive to the terminal marked FACP2 (polarity is in alarm condition) (*Rack Mechanical Drawing & Dimensions pg. 11*).
  - b. For a latching fire alarm interface connect a normally [NO] reset switch to the removable terminals marked [REST] and [GND] (*Figs. 5-10, pg. 9*).
19. Set the power disconnect circuit breaker to the ON position (*Fig. 14a, pg. 11*).

### **Maintenance:**

Unit should be tested at least once a year for the proper operation as follows:

**Output Voltage Test:** Under normal load conditions the DC output voltage should be checked for proper voltage level (*Output Voltage and Stand-by Specification Charts, pg. 5*).

**Battery Test:** Under normal load conditions check that the battery is fully charged, check specified voltage at the battery terminals and at the board terminals marked [- BAT +] to ensure that there is no break in the battery connection wires.

### **Fire Alarm Interface Switch Settings:**

Switch Position		FACP Input
SW1	SW2	
Open	Open	FACP Signal Circuit (Polarity Reversal).
Closed	Closed	FACP Signal Circuit (Polarity Reversal).
Closed	Open	Normally Open [NO] Trigger Input.

### **Output Voltage and Stand-by Specification Charts:**

Altronix Model	Power Supply Board	Battery	20 Min. of Backup	4 Hr. of Backup	24 Hr. of Backup
<b>Maximal1RHDV</b> <b>Maximal1RDV</b>	<i>(Refer to Fig. 1, pg. 6 for Switch [SW1] location and position)</i>	12VDC/40AH*	N/A	3.5 amp	0.5 amp
		24VDC/40AH*	N/A	2.7 amp	0.7 amp
<b>Maximal3RHDV</b> <b>Maximal3RDV</b> <b>Maximal33RDV</b>	<i>(Refer to Fig. 1, pg. 6 for Switch [SW1] location and position)</i>	12VDC/40AH*	N/A	5.5 amp	5.5 amp
		24VDC/40AH*	N/A	5.5 amp	0.7 amp

### **LED Diagnostics:**

#### **Power Supply Board**

LED		Power Supply Status
Red (DC)	Green (AC)	
ON	ON	Normal operating condition.
ON	OFF	Loss of AC, Stand-by battery supplying power.
OFF	ON	No DC output. Short circuit or thermal overload condition.
OFF	OFF	No DC output. Loss of AC. Discharged battery.

#### **Output LEDs on Front Panel**

ON	Output is triggered.
Blinking	FACP disconnect.

**WARNING: To reduce the risk of fire or electric shock, do not expose the unit to rain or moisture. This installation should be made by qualified service personnel and should conform to the National Electrical Code and all local codes.**



The lightning flash with arrow head symbol within an equilateral triangle is intended to alert the user to the presence of an insulated DANGEROUS VOLTAGE within the product's enclosure that may be of sufficient magnitude to constitute an electric shock.



The exclamation point within an equilateral triangle is intended to alert the user to the presence of important operating and maintenance (servicing) instructions in the literature accompanying the appliance.



**CAUTION**  
RISK OF ELECTRIC SHOCK  
DO NOT OPEN



**CAUTION:** To reduce the risk of electric shock do not open enclosure. There are no user serviceable parts inside. Refer servicing to qualified service personnel.

## Power Supply Board Output Voltage Settings:

Fig. 1

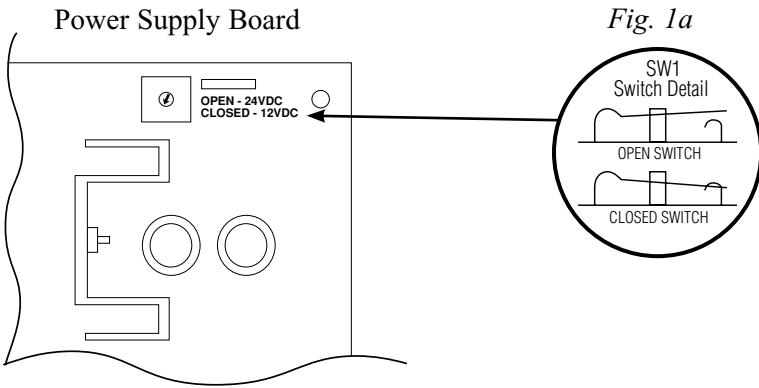

## Fire Alarm Interface, Output Selection and Input Type:

Fig. 2

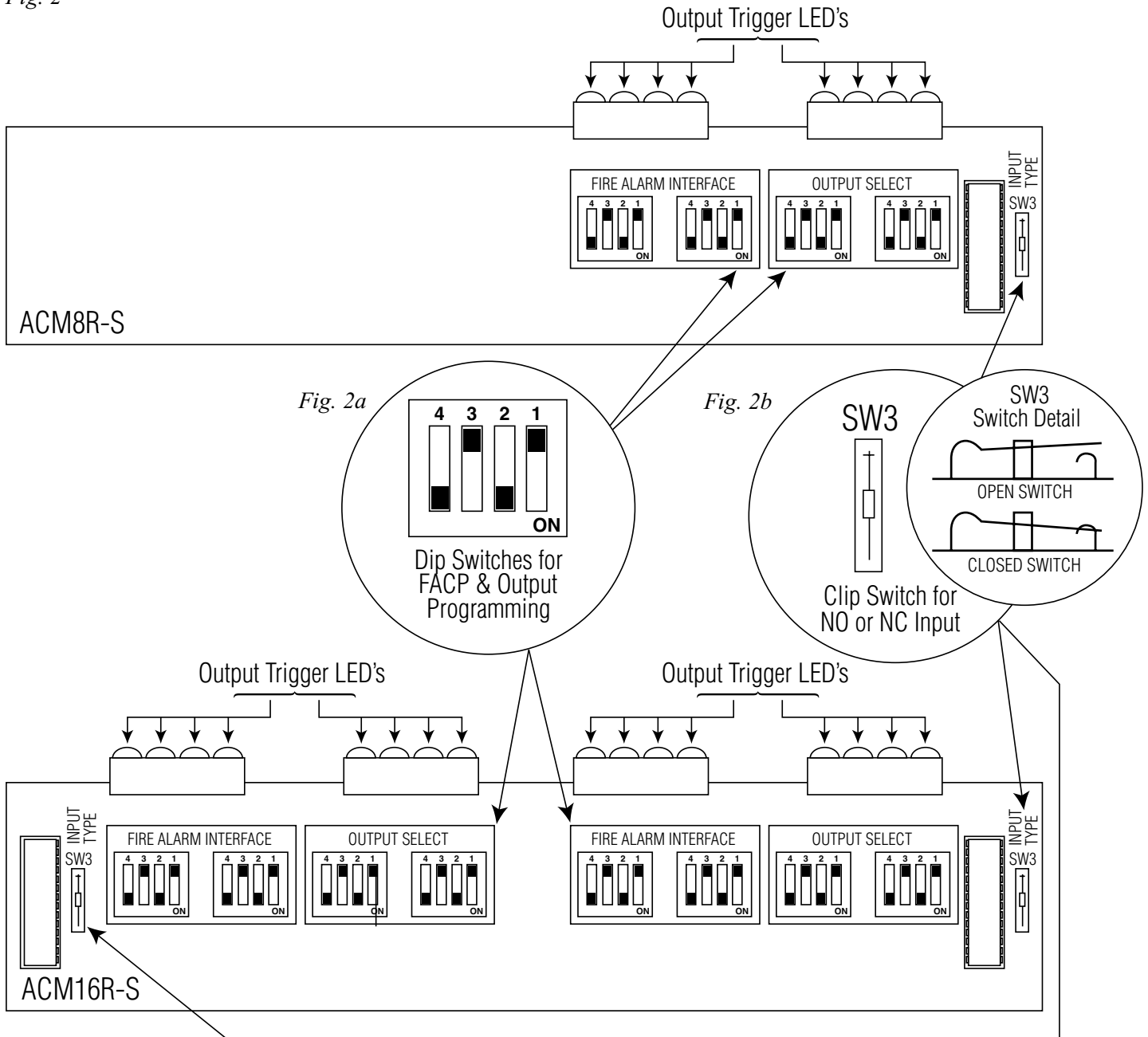

Fig. 3

Fig. 3a

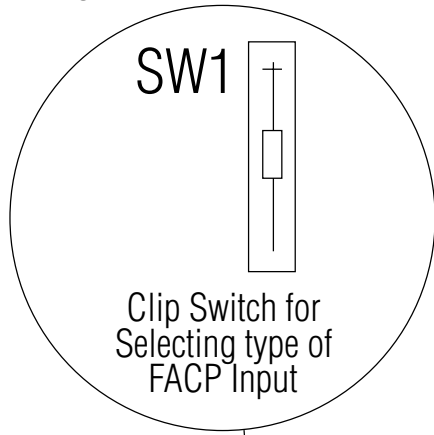

Fig. 3b

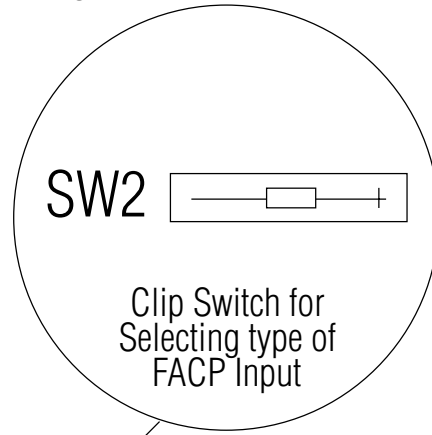
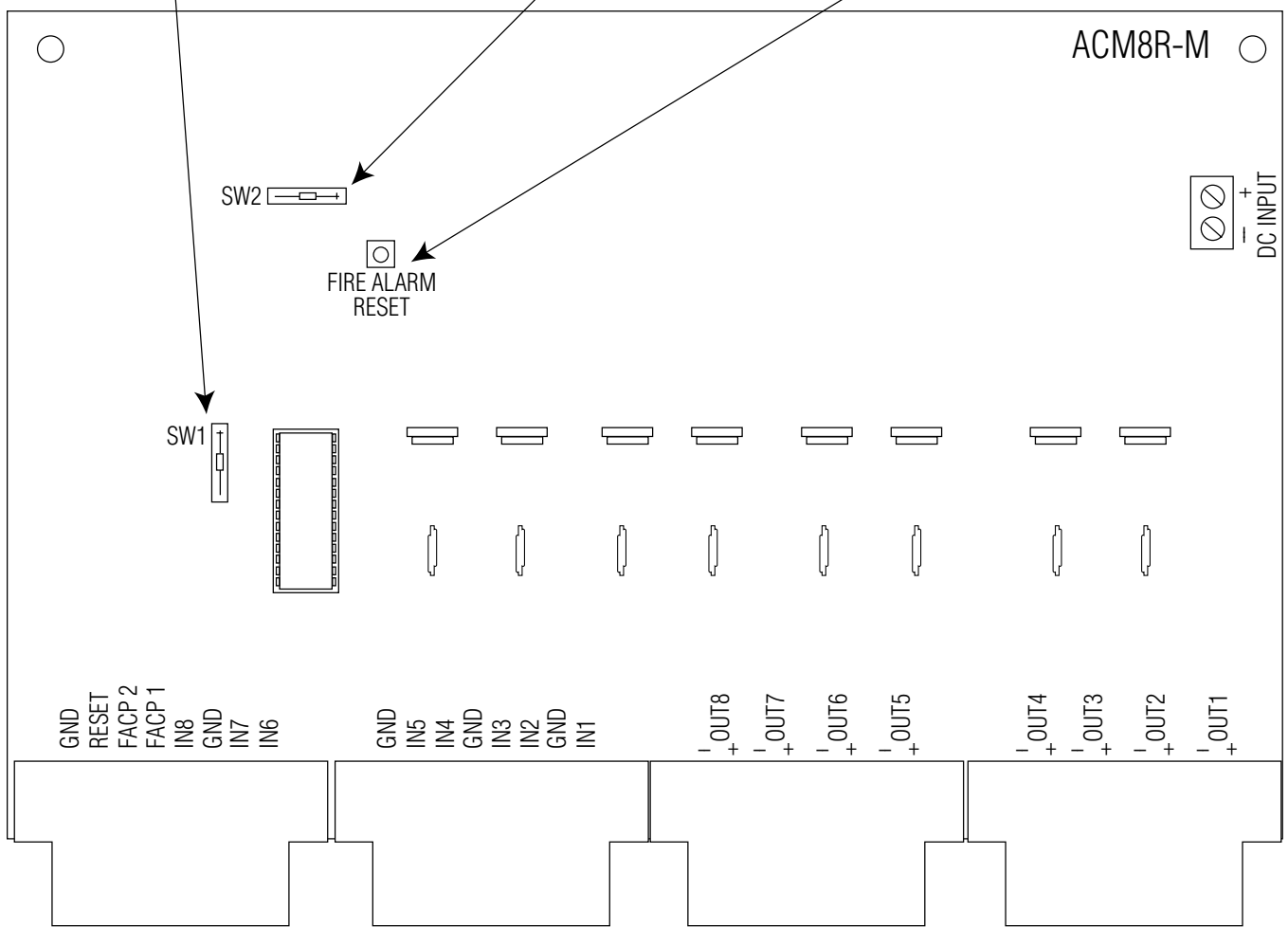
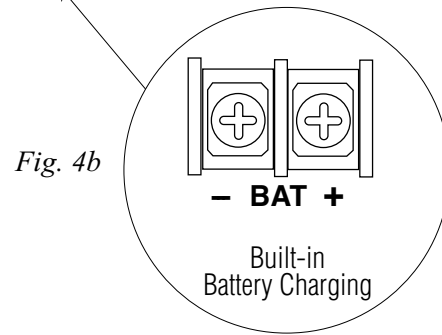
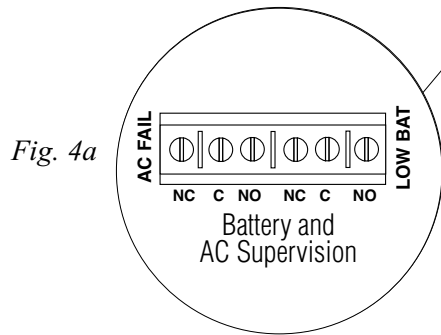
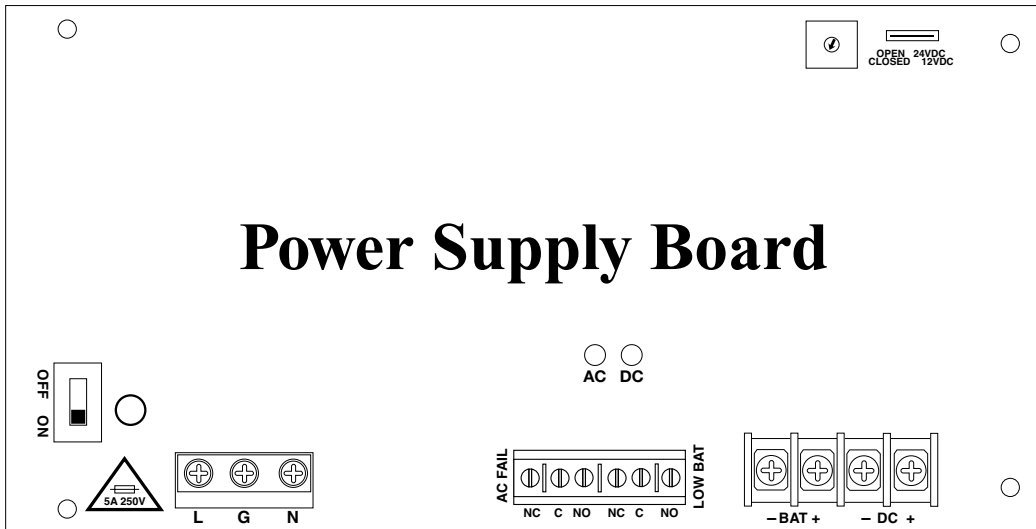

Fig. 3c



# Power Supply Board

Fig. 4





## FACP Hook-Up Diagrams

### Polarity Reversal Input from FACP Signal Circuit Output (Polarity is referenced in alarm condition)

Fig. 5

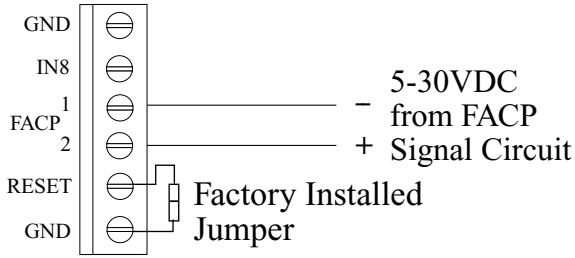

Non-Latching

Fig. 6

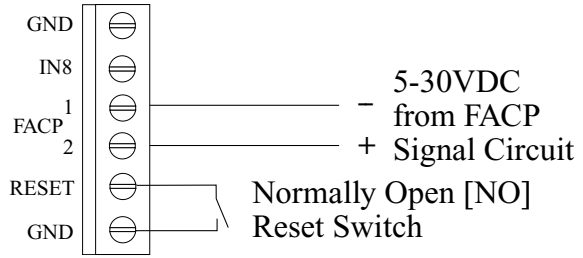

Latching

### Normally Closed Input from FACP

Fig. 7

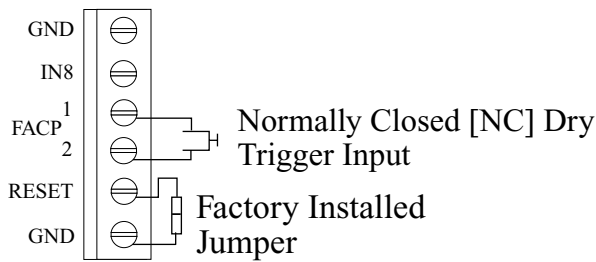

Non-Latching

Fig. 8

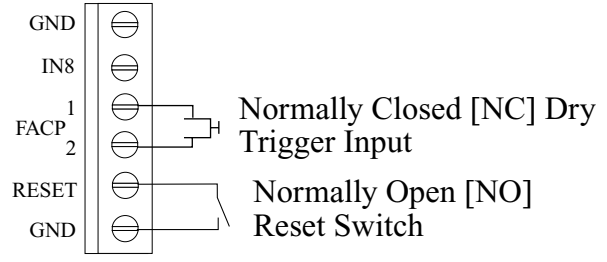

Latching

### Normally Open Input from FACP

Fig. 9

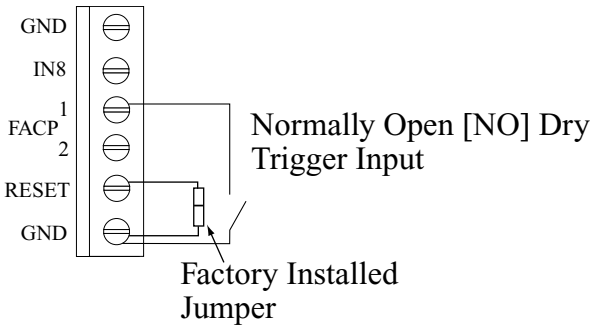

Non-Latching

Fig. 10

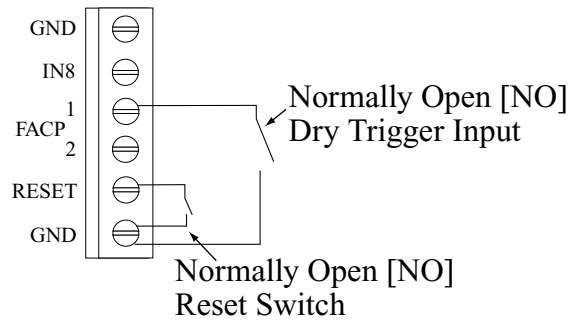

Latching

## Mounting Options:

Fig. 11

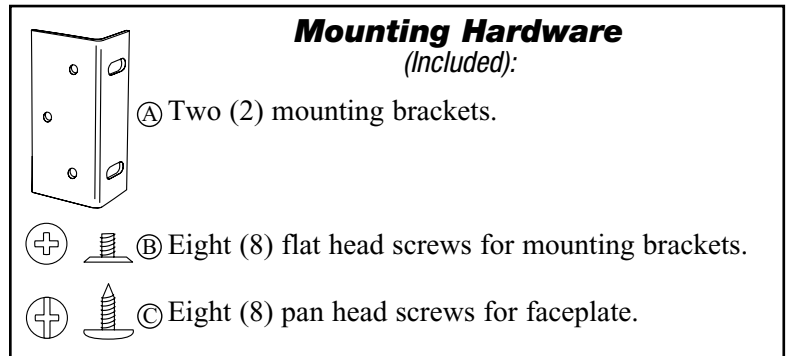
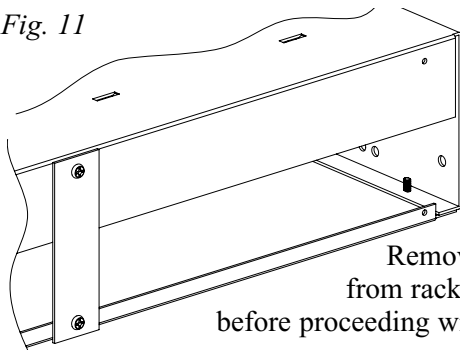

## Rack Mount Installation

1. Remove center brace from rack mount chassis (Fig. 11, pg. 10).
2. Slide mounting brackets (A) into slots located on left and right side of rack enclosure (Fig. 12a).  
Use three (3) flat head screws (B) to secure brackets.
3. Carefully place faceplate over LEDs, and secure using three (3) pan head screws (C) on top and three (3) pan head screws (C) on the bottom of faceplate (Fig. 12b, pg. 10).
4. Slide unit into the desired EIA 19" rack position and secure with mounting screws (not included) (Fig. 12c, pg. 10).

Fig. 12

Fig. 12a

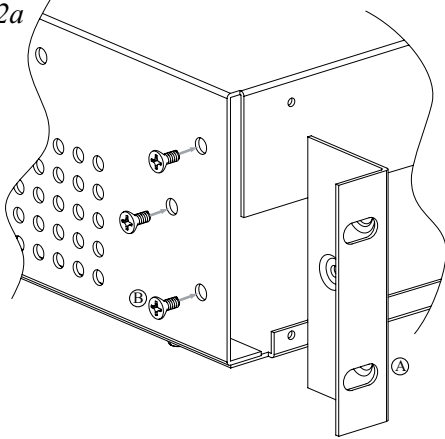

Fig. 12b

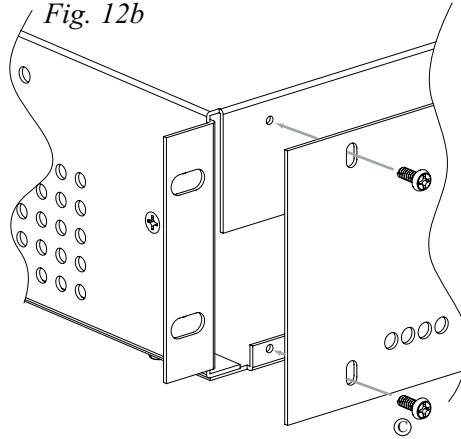
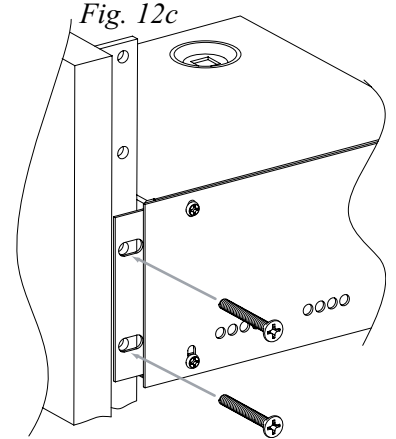

Fig. 12c



## Wall Mount Installation

1. Carefully place faceplate over LEDs, and secure using three (3) pan head screws (C) on top and three (3) pan head screws (C) on the bottom of faceplate (Fig. 13a).
2. Place mounting brackets (A) onto the side of the left and right side of rack enclosure (Fig. 13b).  
Use three (3) flat head screws (B) to secure mounting brackets.
- 3- Mount rack and secure with mounting screws (not included) (Fig. 13c).

Fig. 13

Fig. 13a

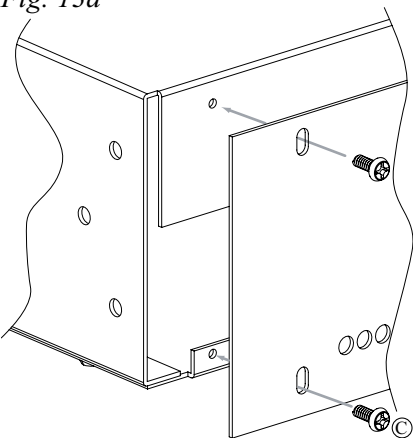

Fig. 13b

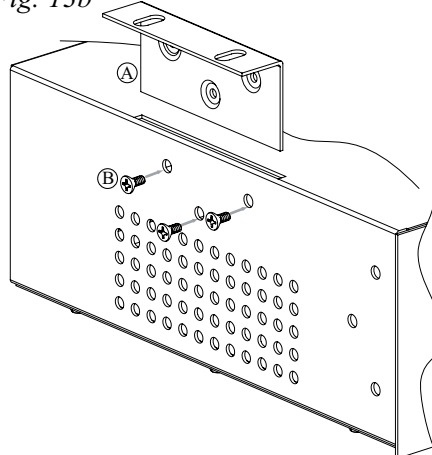
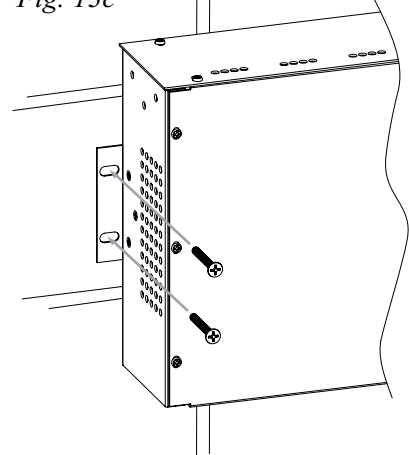

Fig. 13c



# Rack Mechanical Drawing & Dimensions

3.25" x 19.125" x 8.5" (82.55mm x 485.78mm x 215.9mm)

Fig. 14

Fig. 14a

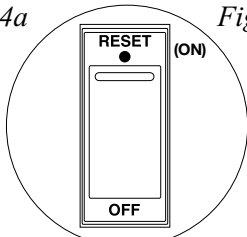

Fig. 14b

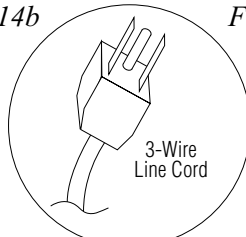
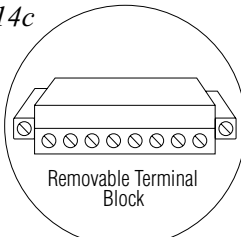
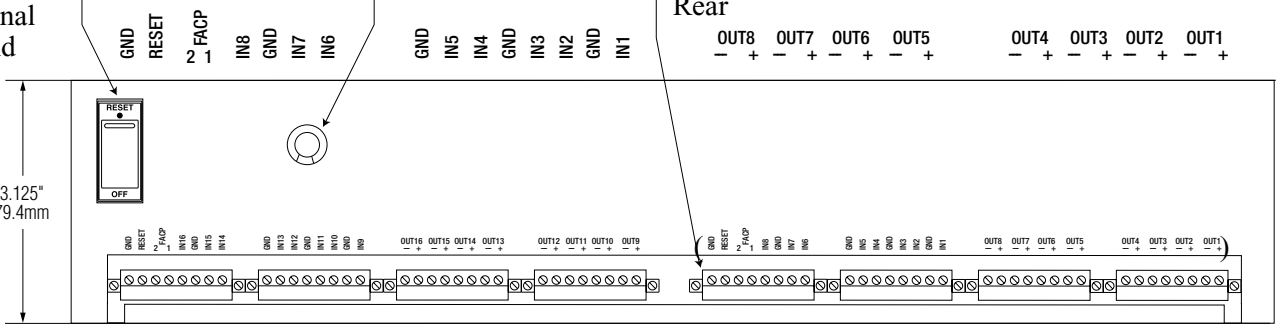

Fig. 14c



Terminal Legend



Rear

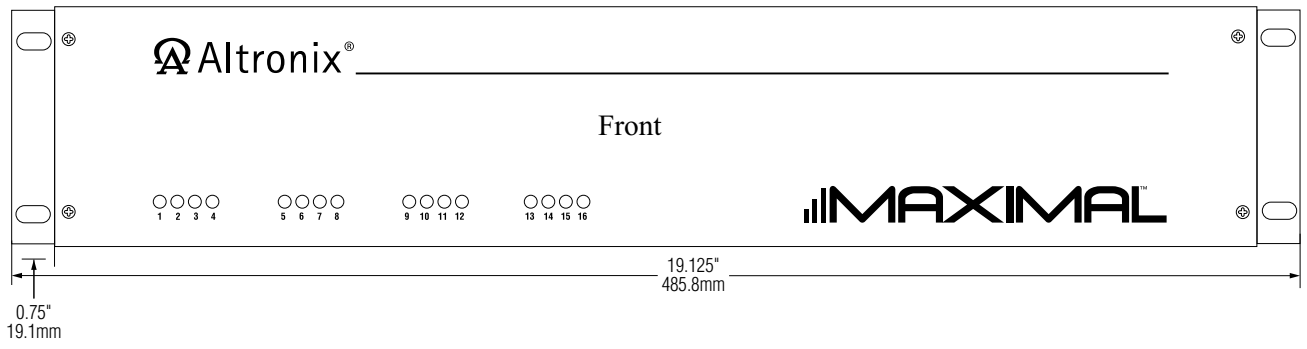
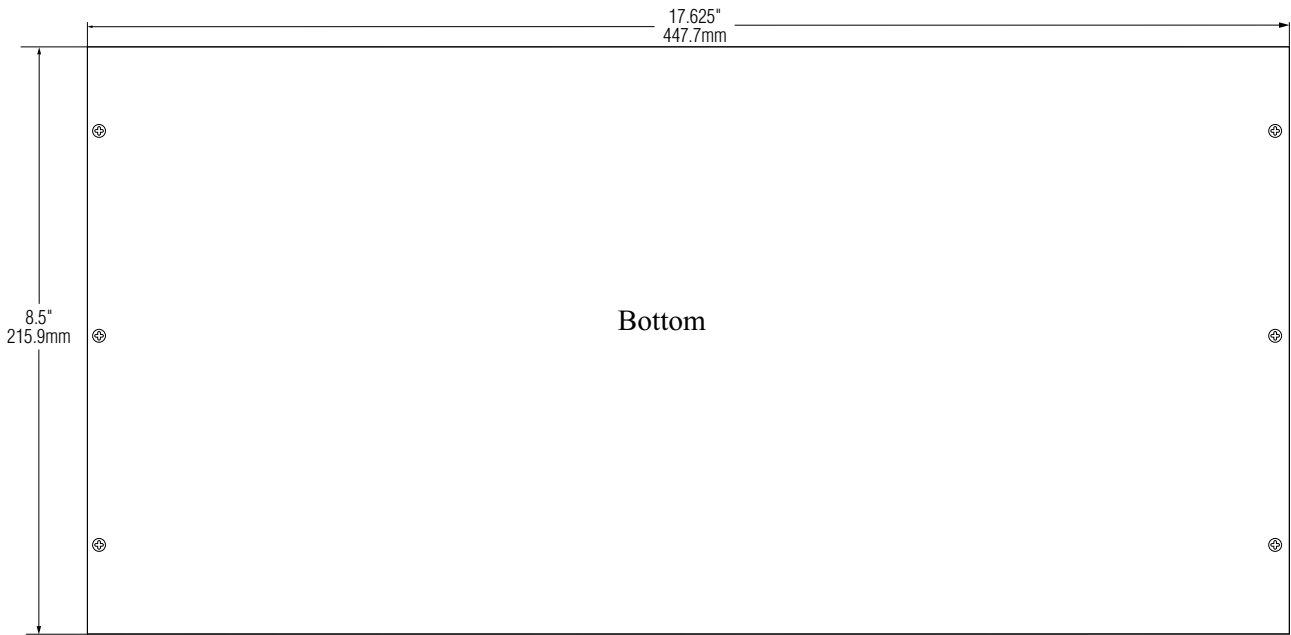

## **Notes:**

Altronix is not responsible for any typographical errors.

140 58th Street, Brooklyn, New York 11220 USA, 718-567-8181, fax: 718-567-9056  
web site: [www.altronix.com](http://www.altronix.com), e-mail: [info@altronix.com](mailto:info@altronix.com), Lifetime Warranty, Made in U.S.A.  
II Maximal220 Rack Mount Series

F30N

- 12 -



Maxim Rack Access Power Controllers (PTC)