

# RESERV

## *Outdoor Video Surveillance UPS*

### *Installation Guide*

#### **Models Include:**

#### **ReServ1WPV**

- Twelve (12) true sine wave regulated 24VAC outputs and Four (4) regulated 12VDC outputs.
- 4A total supply current @ 24VAC and 2A total supply current @ 12VDC.
- PTC protected power-limited outputs.

#### **ReServ2WPV**

- Sixteen (16) true sine wave regulated 24VAC outputs.
- 4A total supply current.
- PTC protected power-limited outputs.

#### **ReServ3WPV**

- Sixteen (16) regulated 12VDC outputs.
- 8A total supply current.
- PTC protected power-limited outputs.



More than just power.™

## Overview:

ReServWPV Outdoor Video Surveillance UPS units are designed to provide power for 24VAC and/or 12VDC cameras during normal or power outage conditions. True sine wave regulated AC outputs and/or regulated DC outputs.

### ReServWPV Series Outdoor Video Surveillance UPS Configuration Reference Chart:

Altronix Model Number	Output/Supply Current (A)	Ambient Temperature	Input Rating	PTC Protected Power-Limited Outputs	24VAC Outputs	12VDC Outputs
ReServ1WPV	24VAC @ 4A (100VA) and 12VDC @ 2A	-33° to 30° C	220VAC 50Hz, 2A	16	12	4
	24VAC @ 3.5A (85VA) and 12VDC @ 2A	-33° to 42° C				
ReServ2WPV	24VAC @ 4A (100VA)	-33° to 30° C	220VAC 50Hz, 2A	16	16	—
	24VAC @ 3.5A (85VA)	-33° to 42° C				
ReServ3WPV	12VDC @ 8A	-33° to 42° C	220VAC 50Hz, 2A	16	—	16

## Specifications:

### Output:

- PTC protected power-limited outputs are rated @ 1A.

### Battery Backup:

- Built-in charger for sealed lead acid or gel type batteries.
- Automatic switchover to stand-by battery when AC fails.

### Supervision:

- AC fail supervision (form “C” contacts).
- Low battery supervision (form “C” contacts).

### Visual and Audio Indicators:

- AC/DC power LED indicators.
- Individual power output LED indicators.
- Low voltage input and Shutdown LED indicators.
- Audio AC Fail and Battery Fail indicator.

### Additional Features:

- True sine wave regulated AC outputs (ReServ1WPV and ReServ2WPV). Regulated DC outputs (ReServ1WPV and ReServ3WPV).
- Unit maintains camera synchronization.
- Ease of installation saves time and eliminates costly labor.

### Enclosure Dimensions:

- NEMA4 / IP66 Rated enclosure.
- Accommodates up to two (2) 12VDC/7AH batteries or two (2) 12VDC/12AH batteries.  
17.375” x 12” x 6.5” (441.3mm x 304.8mm x 165.1mm)

## Stand-by Specifications:

Stand-by Batteries	ReServ1WPV - 4A (100VA) load at 24VAC and 2A load at 12VDC max. ReServ2WPV - 4A (100VA) max. load at 24VAC ReServ3WPV - 8A (100VA) max. load at 12VDC
Two (2) 12VDC/7AH	45 minutes
Two (2) 12VDC/12AH	90 minutes

## Installation Instructions:

This installation should be made by qualified service personnel and should conform to all local codes and in accordance with the National Electrical Code. This product contains no serviceable parts.

1. Remove back plate inside the enclosure by removing the four (4) mounting screws.
2. Mark and drill desired knockouts on the enclosure to facilitate wiring (*Fig. 1, pg. 3*).  
**Note:** It is required to use UL Listed outdoor rated conduit hubs with a minimum outdoor rating of 4X.
3. Secure back plate inside enclosure with the four (4) mounting screws.
4. Mark and drill holes that line up with the top and bottom holes of the enclosure flange Mount unit in the desired location with the appropriate fasteners (*Pgs. 7 and 8*). Secure enclosure to earth ground.  
**Note:** This product needs to be secured to the building/pole before operation.
5. Connect AC power mains to the terminals marked [L] and [N] (*Figs. 2-3, pg. 5-6*).  
Use 18 AWG or larger for all power connections (Battery, output) (*Figs. 2-3, pg. 5-6*).  
Use 18 AWG to 22 AWG for power limited circuits (AC Fail/Low Battery reporting) (*Figs. 2-3, pg. 5-6*).  
**Note:** A readily accessible disconnect device shall be incorporated in the building installation wiring.
6. The LEDs on the power supply board will illuminate when AC power is present.
7. Measure output voltage before connecting cameras/devices to outputs. This helps avoiding potential damage.
8. ReServ3WPV only - Adjust voltage for every two (2) outputs using the corresponding trimpot(s) on the board prior to connecting devices.



## **LED Diagnostics:**

### **Power Supply Board**

Red (DC)	Green (AC1)	Power Supply Status
ON	ON	Normal operating condition.
ON	OFF	Loss of AC. Stand-by battery supplying power.
OFF	ON	No DC output.
OFF	OFF	Loss of AC. Discharged or no stand-by battery. No Dc output.

### **ReServ Board**

LED	LED State		Unit Status
Output LEDs	ON	—	Normal operating condition.
	—	OFF	Loss of 24VACand/or 12VDC output power.
Low Battery	ON	—	Stand-by batteries are low.
	—	OFF	Normal operating condition.
Shutdown	ON	—	Loss of 24VACand/or 12VDC output power. Discharged stand-by battery.
	—	OFF	Normal operating condition.

## **Audio Signal Diagnostics:**

### **ReServ Unit**

Audio Signal	Unit Status
Single Periodic Beep	AC Fail.
Double Periodic Beep	Low Battery or No Battery.

## **Terminal Identification:**

### **Power Supply Board**

Terminal Legend	Function/Description
L, G, N	Connect 220VAC 50Hz to these terminals: L to hot, N to neutral, G to ground.
– DC +	24VDC non power-limited output.
AC FAIL NO, C, NC	Form “C” dry contacts used to instantaneously signal the loss AC to local annunciation devices, with AC present terminals marked NO and C are open, NC and C are closed. When loss of AC occurs, terminals marked NO and C are closed, NC and C are open.
BAT FAIL NO, C, NC	Form “C” dry contacts used to signal low battery voltage or loss of battery voltage. Under normal conditions terminals marked NO and C are open, NC and C are closed. During a trouble condition terminals marked NO and C are closed, and NC and C are open.
– BAT +	Stand-by battery connections. Maximum charge current 0.7A.

### **ReServ Board**

Terminal Legend	Function/Description
Input – 24VDC +	24VDC input from power supply board.
N, P 1-16	24VAC and/or 12VDC outputs.



The lightning flash with arrow head symbol within an equilateral triangle is intended to alert the user to the presence of an insulated DANGEROUS VOLTAGE within the product’s enclosure that may be of sufficient magnitude to constitute an electric shock.



The exclamation point within an equilateral triangle is intended to alert the user to the presence of important operating and maintenance (servicing) instructions in the literature accompanying the appliance.



**CAUTION**  
RISK OF ELECTRIC SHOCK  
DO NOT OPEN



**CAUTION:** To reduce the risk of electric shock do not open enclosure. There are no user serviceable parts inside. Refer servicing to qualified service personnel.

Fig. 2 - ReServ1WPV and Reserv2WPV

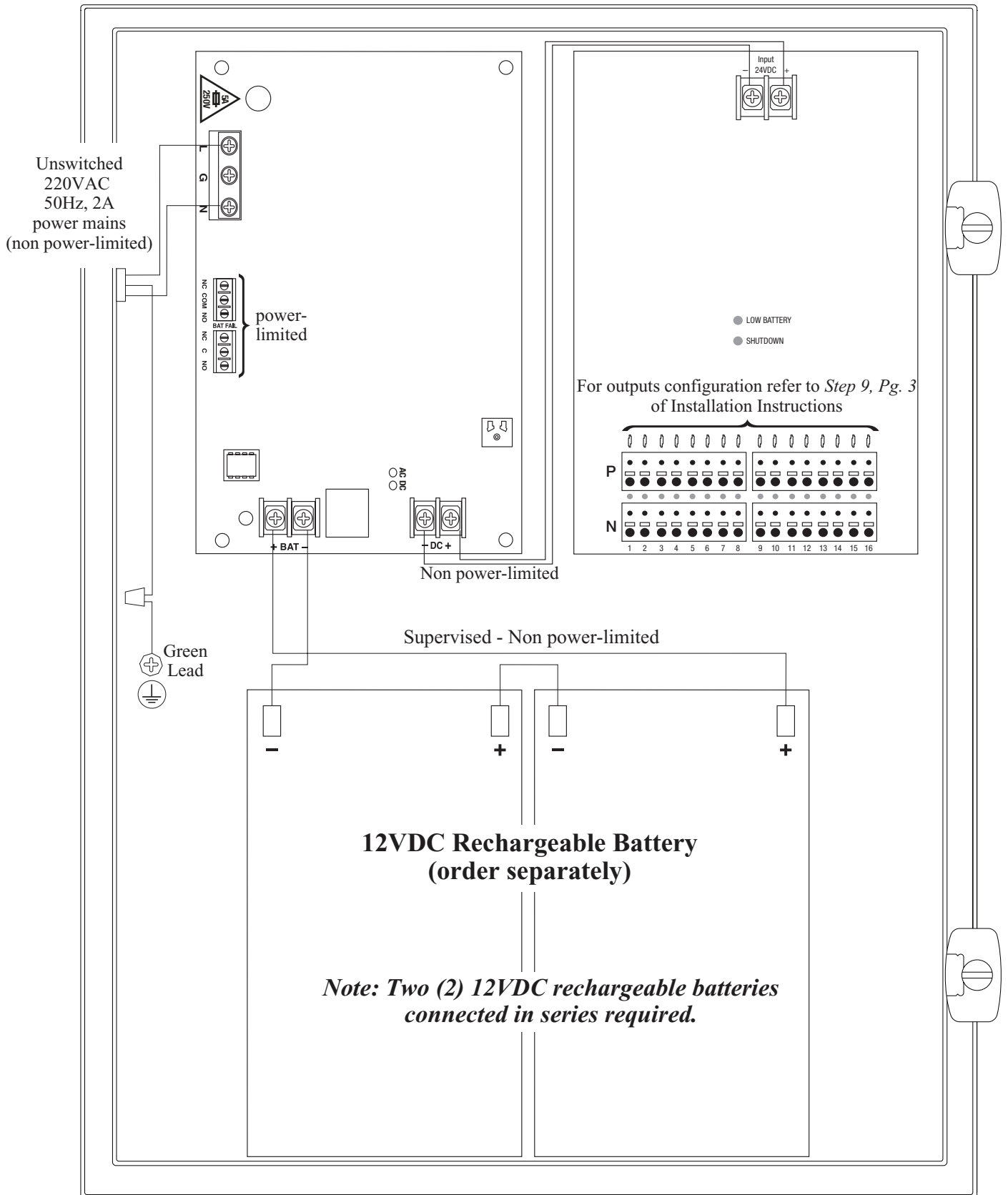

**CAUTION:** Risk of explosion if battery is replaced by an incorrect type. Dispose of used batteries according to the instructions.

Fig. 3 - ReServ3WPV

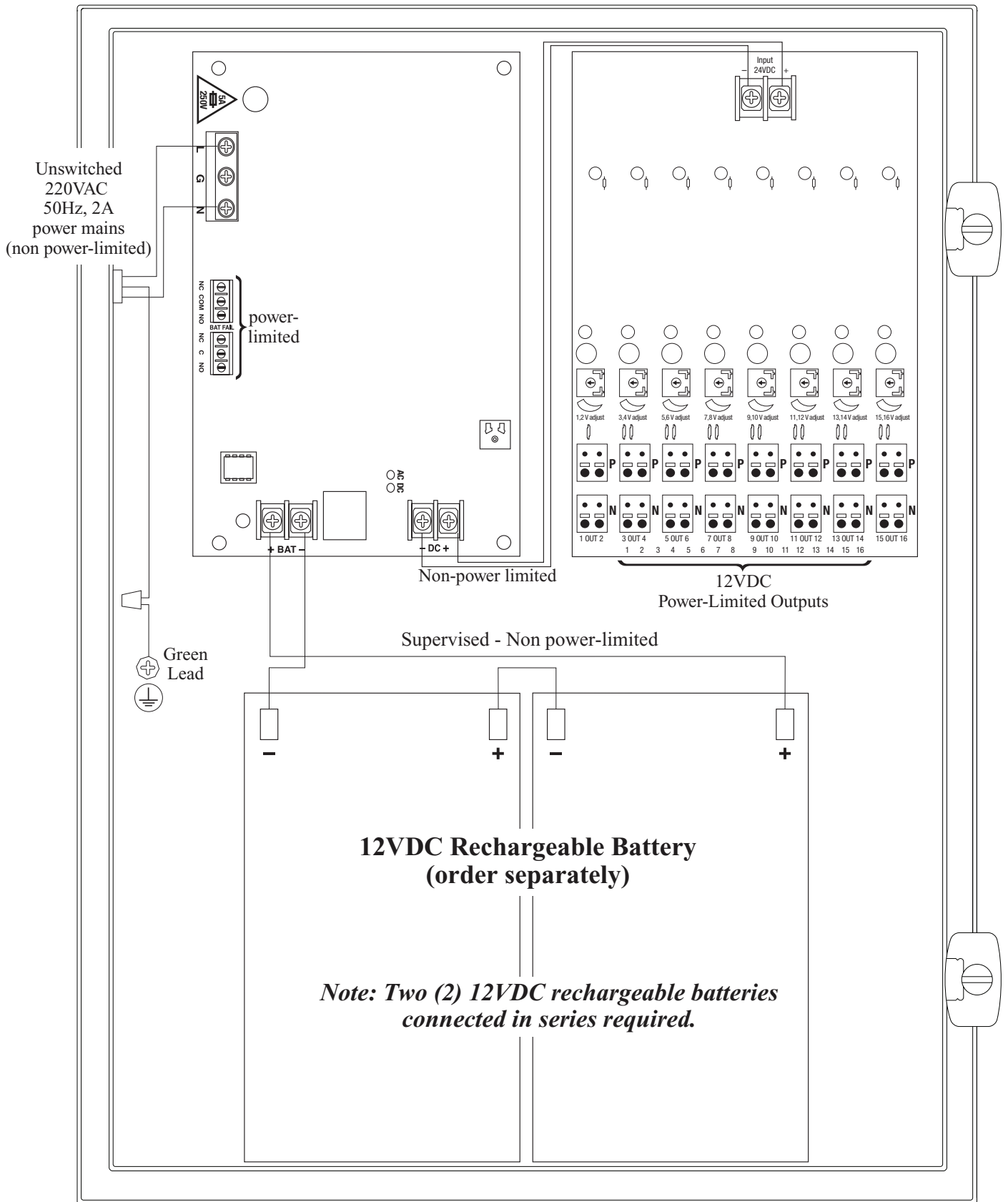

**Note: Two (2) 12VDC rechargeable batteries connected in series required.**

**CAUTION:** Risk of explosion if battery is replaced by an incorrect type. Dispose of used batteries according to the instructions.

## Wall Mount Installation

- 1- Place unit at desired location and secure with mounting screws (not included) (Fig. 4, pg. 7).

Fig. 4

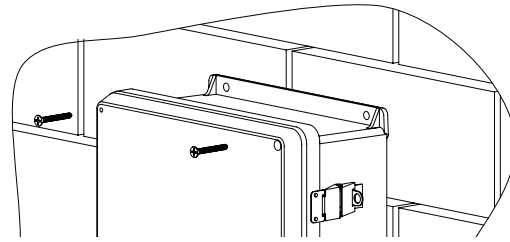

## Pole Mounting Using Optional Pole Mount Kit PMK1 (not included):

This installation should be made by qualified service personnel. This product contains no serviceable parts. PMK1 is intended for use with Altronix outdoor rated power supplies or accessories housed in WP1, WP2, WP3 and WP4 enclosures. Brackets are designed for use with the Wormgear Quick Release Straps (two included).

1. Thread one (1) wormgear quick release strap through the slots on the back of a mounting bracket (Fig. 5, pg. 7).
2. Once the desired height of the top Pole Mount bracket is achieved, tighten the straps down by sliding open end of the strap through the locking mechanism on the strap, then tighten the screw with flat head screwdriver or 5/16" hex socket driver (Fig. 6, pg. 7).

Fig. 5

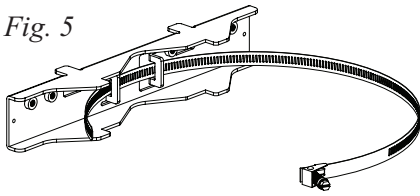

Fig. 6

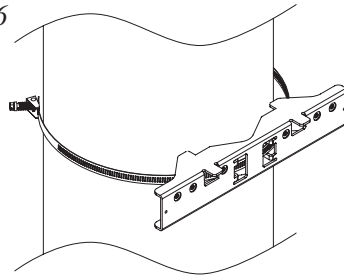
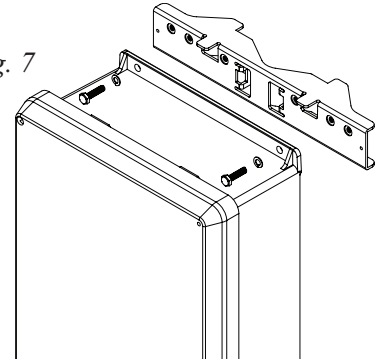

Fig. 7



3. Attach the bottom bracket to the enclosure by inserting bolts through the flange of the enclosure and into the bracket, tightening bolts with a 7/16" hex socket (Fig. 8, pg. 7).
4. Thread the second wormgear quick release strap through the slots on the back of the bottom mounting bracket (Fig. 8, pg. 7).
5. Mount enclosure onto the top bracket by inserting bolts through flange of the enclosure and into the bracket, tightening bolts with a 7/16" hex socket (Fig. 9, pg. 7).
6. Tighten the straps of the bottom bracket down by sliding the open end of the strap through the locking mechanism on the strap, then tighten screw with flat head screwdriver or 5/16" hex socket driver (Fig. 9/9a, pg. 7).
7. Clip excess straps.

Fig. 8

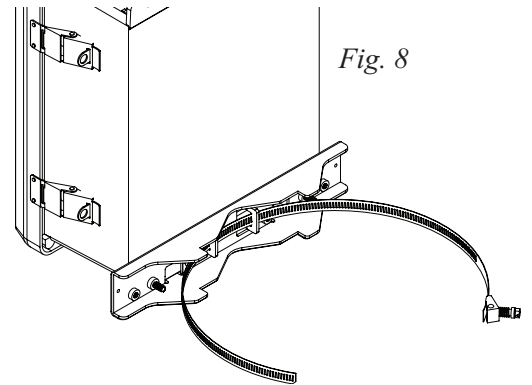

Fig. 9 - 2" to 8" (50.8mm to 203.2mm) diameter round pole

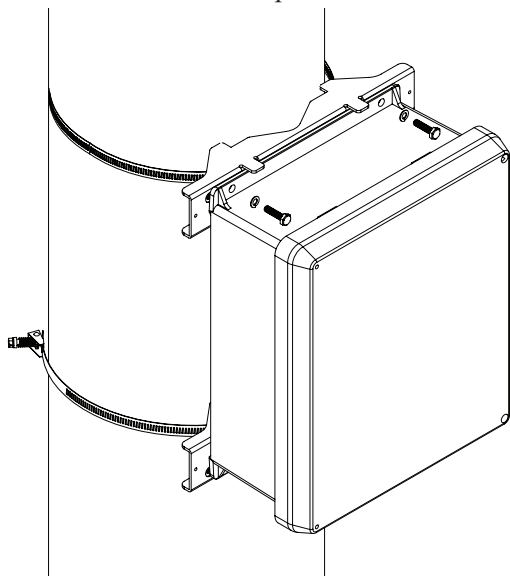
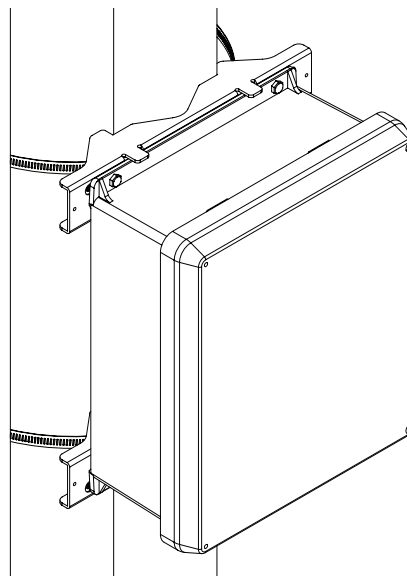
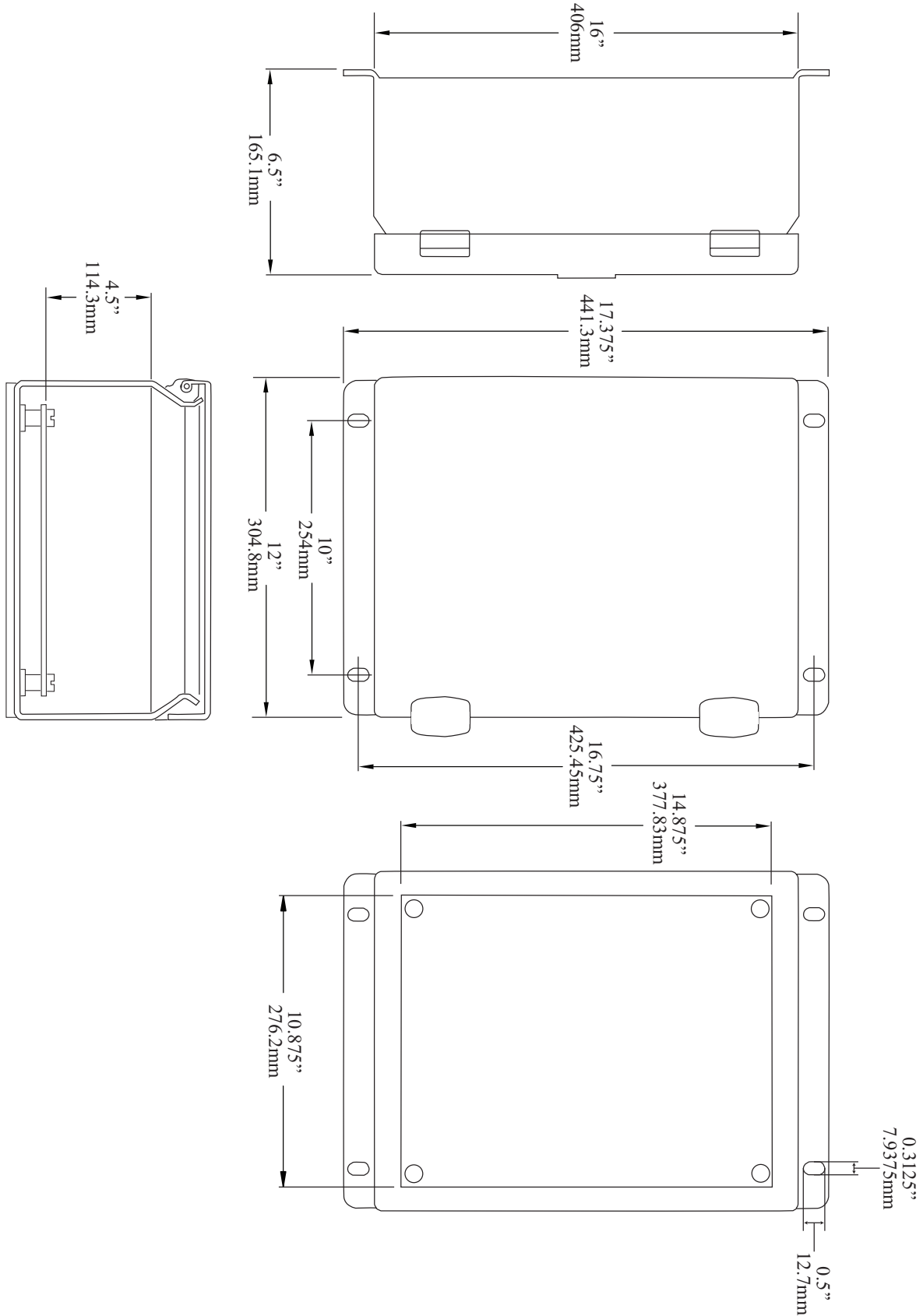

Fig. 9a - 5" (127mm) square pole



**Enclosure Dimensions (H x W x D approximate):**  
 17.375" x 12" x 6.5" (441.3mm x 304.8mm x 165.1mm)



Altronix is not responsible for any typographical errors. Product specifications are subject to change without notice.

140 58th Street, Brooklyn, New York 11220 USA, 718-567-8181, fax: 718-567-9056  
 website: www.altronix.com, e-mail: info@altronix.com. Lifetime Warranty, Made in U.S.A.  
 IIReServWPV Rev. 021412

F16P