

SMP10C24X220 Series Power Supply/Chargers

Installation Guide

Models Include:

SMP10C24X220

- 24VDC @ 10 amp total supply current.

SMP10PM24P4220

- 24VDC @ 10 amp total supply current with supervision.
- Four (4) fuse protected outputs.

SMP10PM24P8220

- 24VDC @ 10 amp total supply current with supervision.
- Eight (8) fuse protected outputs.

SMP10PM24P16220

- 24VDC @ 10 amp total supply current with supervision.
- Sixteen (16) fuse protected outputs.

SMP10PMC24X220

- 24VDC @ 10 amp total supply current with supervision.

SMP10PM24P4C220

- 24VDC @ 10 amp total supply current with supervision.
- Four (4) PTC protected outputs.

SMP10PM24P8C220

- 24VDC @ 10 amp total supply current with supervision.
- Eight (8) PTC protected outputs.

SMP10PM24P16C220

- 24VDC @ 10 amp total supply current with supervision.
- Sixteen (16) PTC protected outputs.

Overview:

SMP10C24X220 Series units convert a 220VAC 50/60Hz input, into a regulated 24VDC @ 10 amp continuous supply current (see specifications).

SMP1024X220 Series Power Supply Configuration Reference Chart:

Altronix Model Number	Accessory Power Distribution Module(s)	Number of Output(s)	Fused Outputs	PTC Outputs	Individual Output Rating	Supervised	220VAC 50/60Hz Input Current	24VDC Total Output Current
SMP10C24X220	—	1	—	—	—	—	1.8 amp	10 amp
SMP10PMC24X220	—	1	—	—	—	✓	1.8 amp	10 amp
SMP10PM24P4220	PD4	4	✓	—	3.5 amp	✓	1.8 amp	10 amp
SMP10PM24P4C220	PD4CB	4	—	✓	2.5 amp	✓	1.8 amp	10 amp
SMP10PM24P8220	PD8	8	✓	—	3.5 amp	✓	1.8 amp	10 amp
SMP10PM24P8C220	PD8CB	8	—	✓	2.5 amp	✓	1.8 amp	10 amp
SMP10PM24P16220	PD16W	16	✓	—	3.5 amp	✓	1.8 amp	10 amp
SMP10PM24P16C22	PD16WCB	16	—	✓	2.5 amp	✓	1.8 amp	10 amp

Specifications:

Input:

- Input 220VAC, 50/60Hz, 1.8 amp.

Output:

- 24VDC output.
- 10 amp supply current.
- Filtered and electronically regulated outputs.
- Short circuit and thermal overload protection.

Battery Backup:

- Built-in charger for sealed lead acid or gel type batteries.
- Maximum charge current 0.7 amp.
- Zero voltage drop when switching over to battery backup.

Supervision (supervised models):

- AC fail supervision (form “C” contacts).
- Low battery supervision (form “C” contacts).

Visual Indicators:

- AC input and DC output LED indicators.

Enclosure Dimensions (H x W x D):

- 13.5” x 13” x 3.25” (342.9mm x 330.2mm x 82.55mm)
 - Accommodates up to two (2)12VDC/7AH batteries.

Installation Instructions:

Wiring methods should be in accordance with the National Electrical Code/NFPA 70/NFPA 72/ANSI and with all local codes and authorities having jurisdiction. Product is intended for indoor use only.

1. Mount unit in the desired location. Mark and predrill holes in the wall to line up with the top two keyholes in the enclosure. Install two upper fasteners and screws in the wall with the screw heads protruding. Place the enclosure’s upper keyholes over the two upper screws; level and secure. Mark the position of the lower two holes. Remove the enclosure. Drill the lower holes and install the three fasteners. Place the enclosure’s upper keyholes over the two upper screws. Install the two lower screws and make sure to tighten all screws (*Enclosure Dimensions, pgs. 6*). Secure enclosure to earth ground.

2. Connect AC power to the terminals marked [L & N] (*Fig. 1, pg. 4 or Fig. 4, pg. 5*). Use 18 AWG or larger for all power connections (Battery, DC output).

Keep power-limited wiring separate from non power-limited wiring (115VAC / 60Hz Input, Battery Wires). Minimum 0.25” spacing must be provided.

CAUTION: Do not touch exposed metal parts. Shut branch circuit power before installing or servicing equipment. There are no user serviceable parts inside. Refer installation and servicing to qualified service personnel.

3. Measure output voltage before connecting devices. This helps avoiding potential damage.
4. Connect devices to be powered:
 - a. For Power Supply Board connect to the terminals marked [- DC +].
 - b. For Power Distribution Module(s) connect devices to be powered to the terminal pairs 1 to 4 marked [1P & 1N through 4P & 4N] (*Fig. 2, pg. 4*), 1 to 8 marked [1P & 1N through 8P & 8N] (*Fig. 3, pg. 4*), or 1 to 16 marked [1P & 1N through 16P & 16N] (*Fig. 5, pg. 5*) carefully observing correct polarity.

5. When using stand-by batteries, they must be lead acid or gel type. Connect battery to the terminals marked [- BAT +] (battery leads included), (Fig. 1, pg. 4 or Fig. 4, pg. 5).

Note: When batteries are not used, a loss of AC will result in the loss of output voltage.

6. For Supervised Models Only:

Connect appropriate signaling notification devices to AC Fail & Low Bat supervisory relay outputs marked [N.C., C, N.O.] (Fig. 1a, pg. 4, Fig. 4a, pg. 5).

LED Diagnostics:

OLS250220/OLS257220 - Power Supply Board

Red (DC)	Green (AC)	Power Supply Status
ON	ON	Normal operating condition.
ON	OFF	Loss of AC. Stand-by battery supplying power.
OFF	ON	No DC output.
OFF	OFF	Loss of AC. Discharged or no stand-by battery. No DC output.

PD4/PD4CB/PD8/PD8CB - Power Distribution Module

Green	Power Distribution Module Status
ON	Normal operating condition.

Terminal Identification:

OLS250220/OLS257220 - Power Supply Board

Terminal Legend	Function/Description
L, G, N	Connect 220VAC to these terminals: L to Hot, N to Neutral.
- DC +	24VDC @ 10 amp total supply current.
*AC FAIL N.C., C, N.O.	Used to notify loss of AC power, e.g. connect to audible device or alarm panel. Relay normally energized when AC power is present. Contact rating 1 amp @ 120VAC / 28VDC.
*Low Battery N.C., C, N.O.	Used to indicate low battery condition, e.g. connect to alarm panel. Relay normally energized when DC power is present. Contact rating 1 amp @ 120VAC / 28VDC. Low battery threshold: 24VDC output threshold set @ approximately 21VDC.
- BAT +	Stand-by battery connections. Maximum charge rate 0.7 amp.

***Note:** Supervised Models Only.

PD4/PD4CB/PD8/PD8CB/PD16W/PD16WCB - Power Distribution Module

Terminal Legend			Function/Description
PD4/PD4CB	PD8/PD8CB	PD16W/PD16WCB	
1P to 4P	1P to 8P	1P to 16P	Positive DC power outputs.
1N to 4N	1N to 8N	1N to 16N	Negative DC power outputs.

CAUTION: De-energize unit prior to servicing. For continued protection against risk of electric shock and fire hazard replace fuse with the same type and rating 5A, 250V.

Fig. 1

Fig. 1a

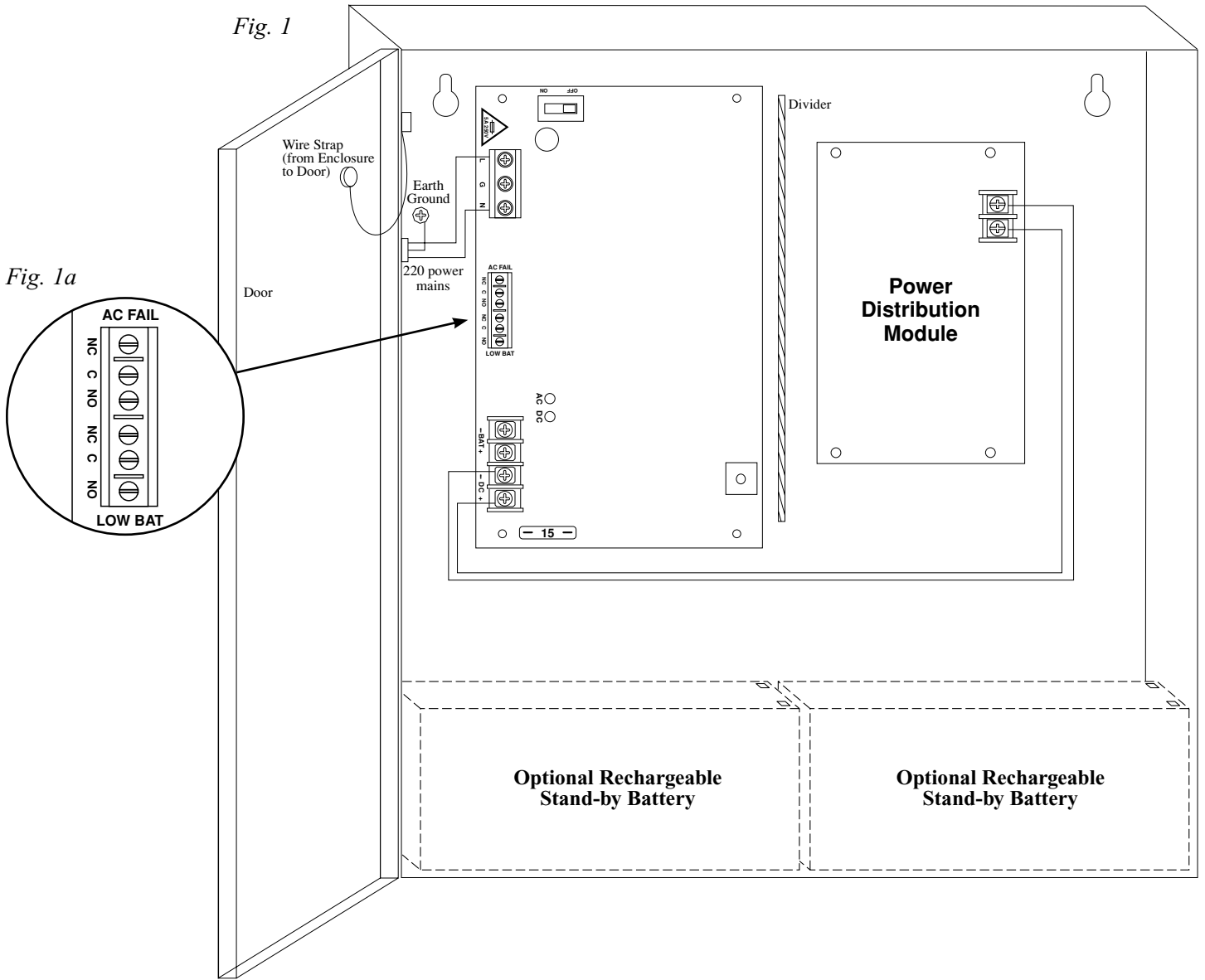

Power Distribution Module(s):

Fig. 2

PD4/PD4CB

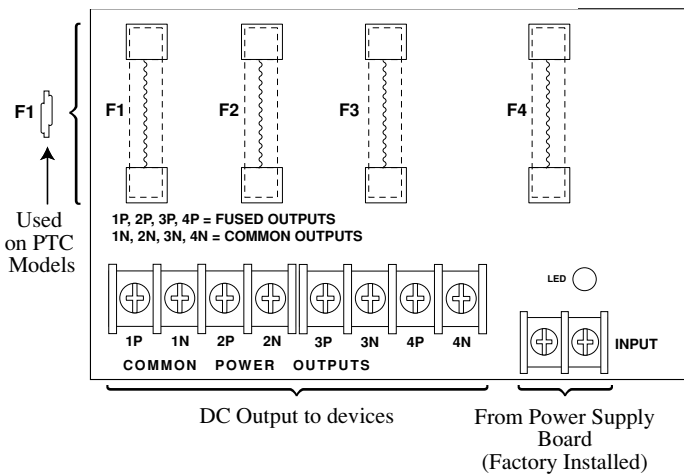
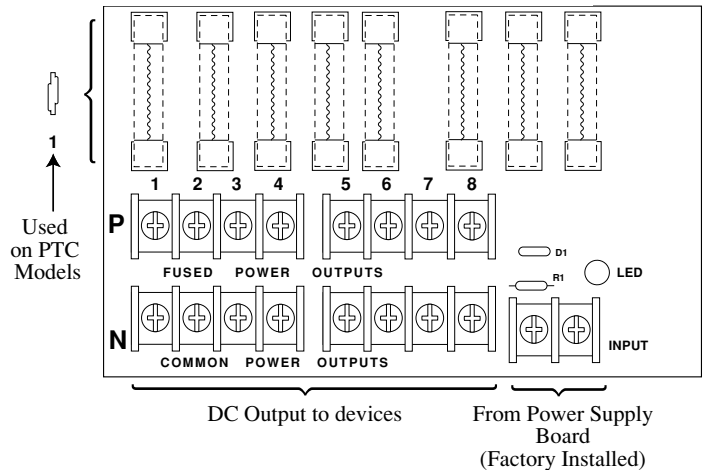

Fig. 3

PD8/PD8CB



CAUTION: De-energize unit prior to servicing. For continued protection against risk of electric shock and fire hazard replace fuse with the same type and rating 5A, 250V.

Fig. 4

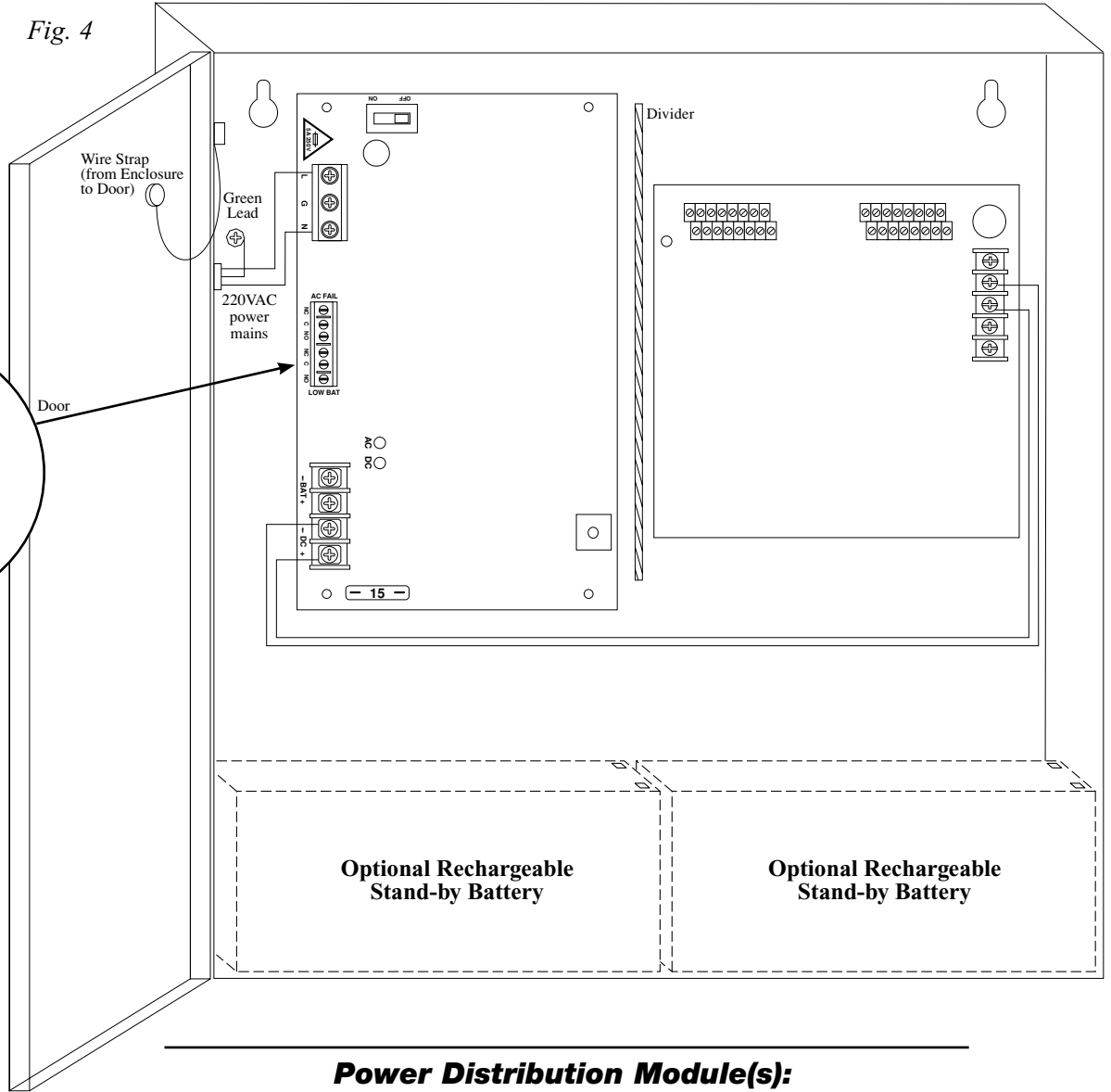
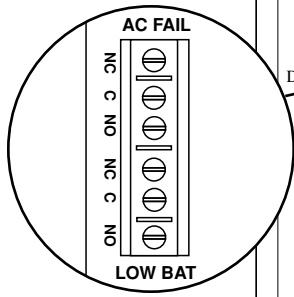
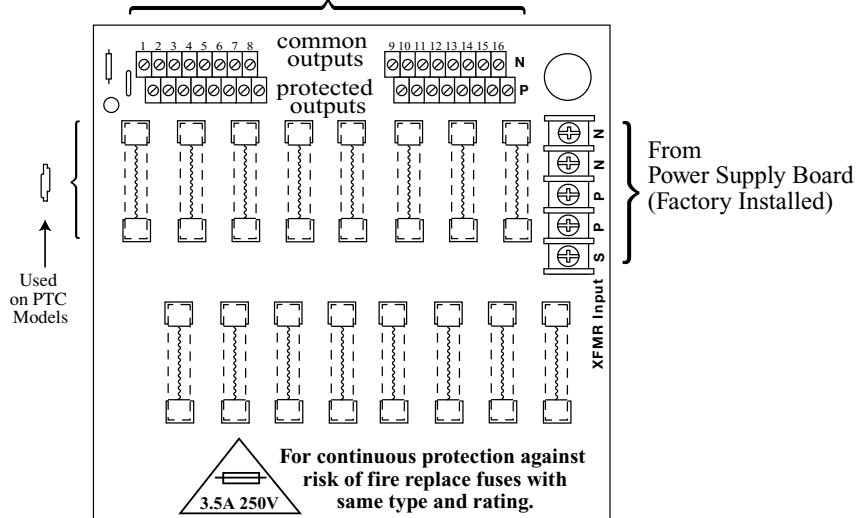

Fig. 4a



Power Distribution Module(s):

Fig. 5
DC Output to devices
1P-16P Power Outputs,
1N-16N Common Outputs



PD16W/PD16WCB

Enclosure Dimensions:

13.5" x 13" x 3.25" (342.9mm x 330.2mm x 82.55mm)

Enclosure accommodates up to two (2) 12VDC/7AH batteries.

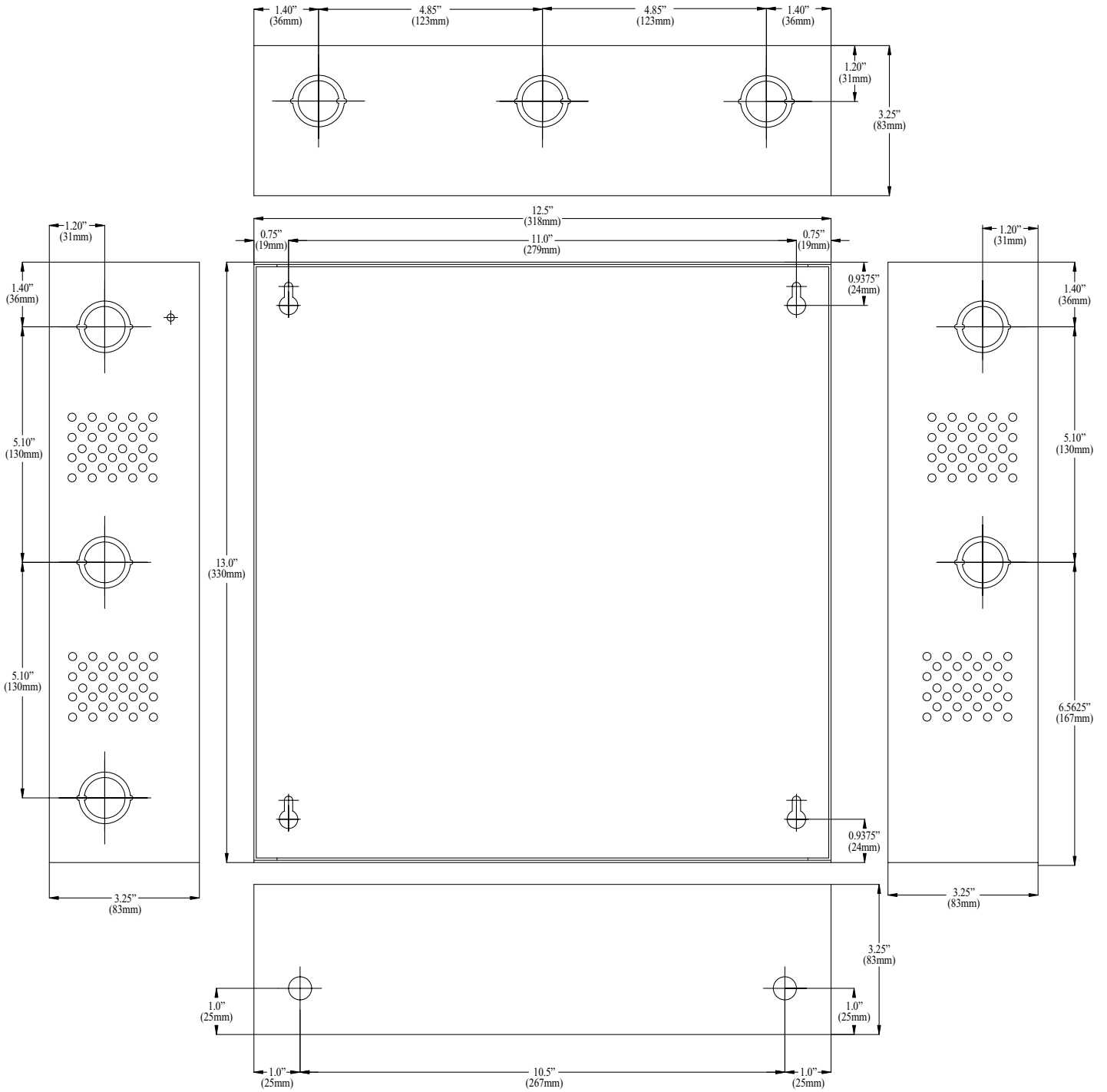

Notes:

Notes:

Altronix is not responsible for any typographical errors. Product specifications are subject to change without notice.

140 58th Street, Brooklyn, New York 11220 USA, 718-567-8181, fax: 718-567-9056
web site: www.altronix.com, e-mail: info@altronix.com, Made in U.S.A.
IISMP10C24X - Rev. 012610

G14N

- 8 -



MEMBER

SMP1024X220series