



SMP3E

High Current Power Supply/Charger

Overview:

Altronix SMP3E High Current Power Supply/Charger converts a low voltage AC input to a low voltage DC output. This general purpose power supply has a wide range of applications for access control, security and CCTV system accessories that require additional power.

Specifications:

Input:

- 16VAC to 28VAC.

Output:

- 6VDC, 12VDC or 24VDC selectable output.
- 2.5A continuous supply current.
- Filtered and electronically regulated output.
- Short circuit and thermal overload protection.

Battery Backup:

- Built-in charger for sealed lead acid or gel type batteries.
- Automatic switch over to stand-by battery when AC fails.
- Maximum charge current 0.3A.
- Battery short circuit protection (circuit breaker).

Visual Indicators:

- AC input and DC output LED indicators.

Features:

- Includes battery leads.
- Power supply/charger with enclosure.

Board Dimensions (W x L x H approximate):

3" x 3.5" x 2" (76.2mm x 88.9mm x 50.8mm).

Enclosure Dimensions (H x W x D approximate):

8.5" x 7.5" x 3.5" (215.9mm x 190.5mm x 88.9mm).

- Fits one (1) 12VDC/7AH or two (2) 12VDC/4AH batteries.

Voltage Output/Transformer Selection Table:

Output Voltage	Switch Position		Transformer Requirements (Recommended Altronix Part #'s)
	1	2	
6VDC	ON	OFF	16VAC / 40VA (TP1640).
12VDC	OFF	OFF	16VAC / 40VA (TP1640), 24VAC or 28VAC / 100VA (T2428100).
24VDC	OFF	ON	28VAC / 100VA (T2428100).

Note: Transformers with higher VA ratings may be used for all output voltages above as long as you do not exceed 28VAC or 45VDC.

Installation Instructions:

1. Mount power supply board into the enclosure (*see Step 1 and Step 2, pg. 2*).
2. Mount unit in the desired location. Mark and predrill holes in the wall to line up with the top two keyholes in the enclosure. Install two upper fasteners and screws in the wall with the screw heads protruding. Place the enclosure's upper keyholes over the two upper screws; level and secure. Mark the position of the lower two holes. Remove the enclosure. Drill the lower holes and install two fasteners. Place the enclosure's upper keyholes over the two upper screws. Install two lower screws and make sure to tighten all screws (*Enclosure Dimensions, pg. 2*). Secure enclosure to earth ground.
3. Set DC output voltage with switches (refer to *Voltage Output/Transformer Selection Table*).
4. Connect proper transformer to the terminals marked [AC] (refer to *Voltage Output/Transformer Selection Table*). Use 18 AWG or larger for all power connections (Battery, DC output).

Keep power-limited wiring separate from non power-limited wiring (115VAC / 60Hz Input, Battery Wires).

Minimum 0.25" spacing must be provided.

CAUTION: Do not touch exposed metal parts. Shut branch circuit power before installing or servicing equipment.

There are no user serviceable parts inside. Refer installation and servicing to qualified service personnel.

5. Measure output voltage before connecting devices. This helps avoiding potential damage.
6. Connect devices to be powered to the terminals marked [+ DC -], carefully observing polarity.
7. Connect battery to the terminals marked [+ BAT -] (battery leads included)

Note: When batteries are not used, a loss of AC will result in a loss of output voltage.

LED Diagnostics:

Red (DC)	Green (AC)	Power Supply Status
ON	ON	Normal operating condition.
ON	OFF	Loss of AC. Stand-by battery supplying power.
OFF	ON	No DC output. Short circuit or thermal overload condition.
OFF	OFF	No DC output. Loss of AC. Discharged or no battery present.

Terminal Identification:

Terminal Legend	Function/Description
AC/AC	Low voltage AC input (see Voltage Output/Transformer Selection Table). For 6VDC output use 16VAC or higher with 24VA power rating or higher. For 12VDC output use 16VAC or higher with 40VA power rating or higher. For 24VDC output use 28VAC with 85VA power rating or higher. Caution: Do not apply voltage above 28VAC or 45VDC (maximum input rating).
+ DC -	6VDC, 12VDC or 24VDC @ 2.5A continuous supply current.
+ BAT -	Stand-by battery connections. Maximum charge rate 300mA.

Enclosure Dimensions(H x W x D approximate):

8.5" x 7.5" x 3.5" (215.9mm x 190.5mm x 88.9mm)

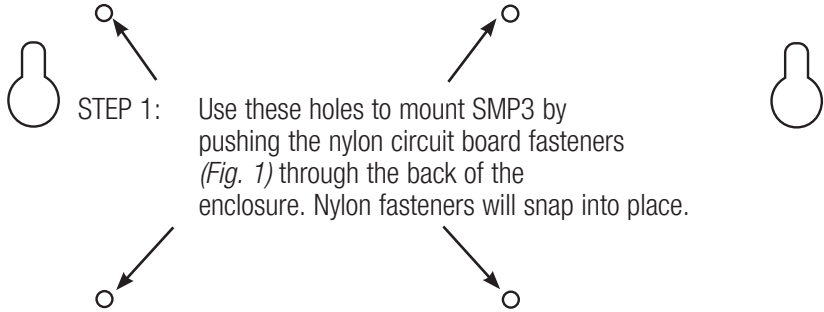

STEP 1: Use these holes to mount SMP3 by pushing the nylon circuit board fasteners (*Fig. 1*) through the back of the enclosure. Nylon fasteners will snap into place.

STEP 2: Mount SMP3 circuit board to nylon fasteners by pressing down circuit board onto nylon fasteners.

Note: Springlock on fasteners is used to remove SMP3 circuit board.

Note: Four (4) fasteners are provided in the SMP3 carton.

Springlock

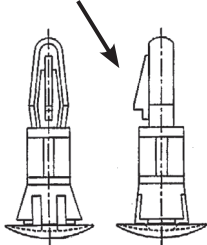

Fig. 1
Nylon Fastener

