

Access & Power Integration

Altronix/Mercury Wired Kits

Models Include:

T2M35XK1

8 Door Kit with Fused Outputs

Fully assembled kit includes:

- Trove2 enclosure with TM2 Altronix/Mercury backplane and TMV2 Altronix/Mercury door backplane
- One (1) eFlow6NB - Power Supply/Charger
- One (1) eFlow102NB - Power Supply/Charger
- Two (2) ACM8 - Fused Access Power Controllers
- One (1) Rocker Switch Bracket with Two (2) Rocker Switches
- Wire harnesses and finger duct

T2M35XK1D

8 Door Kit with PTC Outputs

Fully assembled kit includes:

- Trove2 enclosure with TM2 Altronix/Mercury backplane and TMV2 Altronix/Mercury door backplane
- One (1) eFlow6NB - Power Supply/Charger
- One (1) eFlow102NB - Power Supply/Charger
- Two (2) ACM8CB - PTC Access Power Controllers
- One (1) Rocker Switch Bracket with Two (2) Rocker Switches
- Wire harnesses and finger duct

Please refer to the included corresponding Sub-Assembly Installation Guides for further information.

Installation Guide



All registered trademarks are property of their respective owners

Rev. 111824

Installing Company: _____ Service Rep. Name: _____

Address: _____ Phone #: _____



More than just power.™

Overview:

Altronix T2M35XK1(D) Trove Mercury wired kit is pre-assembled and consists of Trove enclosure/backplanes with factory installed Altronix power supply/chargers and sub-assemblies. It also accommodates a variety of Mercury modules for up to eight doors in a single enclosure.

Configuration Chart:

Altronix Model Number	120VAC 60Hz Input Current (A)	Power Supply Board Input Fuse Rating	Power Supply Board Battery Fuse Rating	Nominal DC Output Voltage				Maximum Supply Current for Main and Aux. Outputs on Power Supply boards and ACM8(CB) Access Power Controller's outputs	Fail-Safe/ Fail-Secure Outputs	Current Per ACM8(CB) Output (A)	ACM8(CB) Board Input Fuse Rating	ACM8(CB) Board Output Fuse (PTC) Rating
				Power Supply 1		Power Supply 2						
				[DC]	[Aux]	[DC]	[Aux]					
				Output Range (VDC)	Output Range (VDC)	Output Range (VDC)	Output Range (VDC)					
T2M35XK1	7	5A/250V	eFlow6NB: 10A/32V	20.17- 26.4	20.28- 26.4	9.7- 13.2	10.03- 13.2	24VDC @ 5.7A + 12VDC @ 9.7A	16	2.5	10A/ 250V	3.5A/ 2502V
T2M35XK1D			eFlow102NB: 15A/32V							2.0	10A/ 250V	2.5A

Installation Instructions:



Wiring methods shall be in accordance with the National Electrical Code/NFPA 70/ANSI, and with all local codes and authorities having jurisdiction. Product is intended for indoor use only.

1. Remove backplane from enclosure. Do not discard hardware.
2. Mark and predrill holes in the wall to line up with the top three keyholes in the enclosure. Install three upper fasteners and screws in the wall with the screw heads protruding. Place the enclosure's upper keyholes over the three upper screws; level and secure. Mark the position of the lower three holes. Remove the enclosure. Drill the lower holes and install the three fasteners. Place the enclosure's upper keyholes over the three upper screws. Install the three lower screws and make sure to tighten all screws.
3. Mount included UL Listed tamper switch (Altronix Model TS112 or equivalent) in desired location, opposite hinge. Slide the tamper switch bracket onto the edge of the enclosure approximately 2" from the right side (*Fig. 1, pg. 2*). Connect tamper switch wiring to the Access Control Panel input or the appropriate UL Listed reporting device. To activate alarm signal open the door of the enclosure.
4. Connect unswitched AC power (120VAC 60Hz) to RSB1. Use 14 AWG or larger for all power connections. Secure green wire lead to earth ground. Green "AC" LED on power supply board will turn on. This light can be seen through the LED lens on the door of the enclosure.
Keep power-limited wiring separate from non power-limited wiring (120VAC 60Hz Input, Battery Wires). Minimum 0.25" spacing must be provided.
CAUTION: Do not touch exposed metal parts. Shut branch circuit power before installing or servicing equipment. There are no user serviceable parts inside.
Refer installation and servicing to qualified service personnel.
5. Measure voltage before connecting devices. This helps avoiding potential damage.
6. Mount Mercury modules to backplane(s), refer to *page 3, 4*.
7. Refer to the *eFlow Power Supply/Charger Installation Guide* for eFlow6NB and eFlow102NB and corresponding *Installation Guides* for ACM8(CB) for further installation instructions.

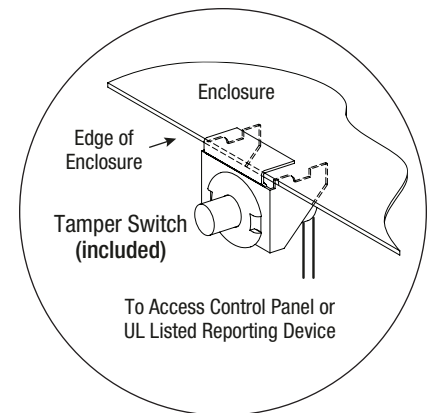
Fig. 1



Hardware:

 Snap On Spacer |
  5/16" Pan Head Screw |
  Lock Nut

T2M35XK1(D): Configuration of Mercury Boards on TM2 Backplane:

1. Position access controller module over corresponding spacers and depress onto snap on spacers (Fig. 2, pg. 3).
2. Mount backplane to enclosure with hardware.

Access Controller Position Chart for the Following Models:

LenelS2 / Mercury Access Controller	Pem Mounting
LP1502	(A)
MR52	(B)

Fig. 2

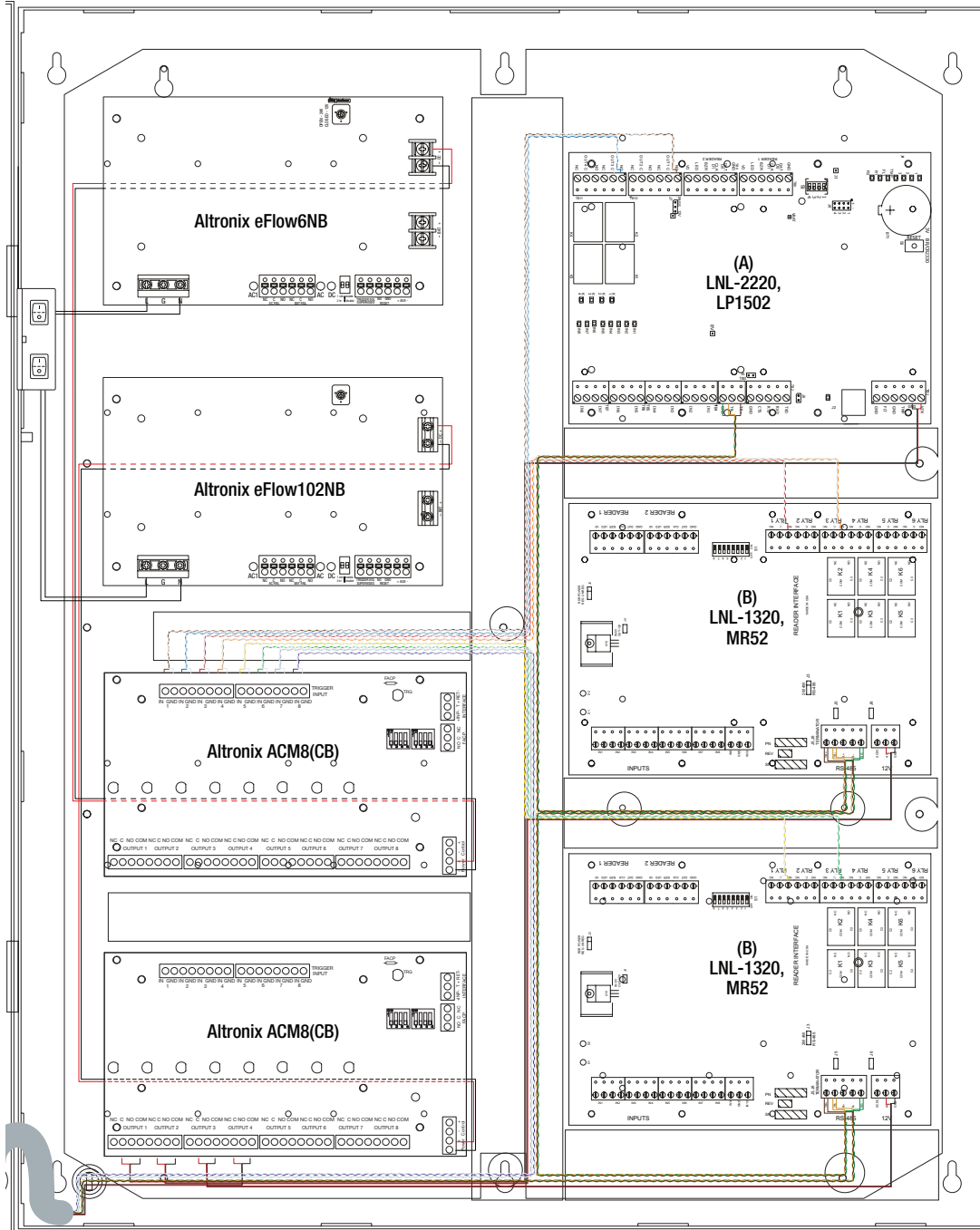
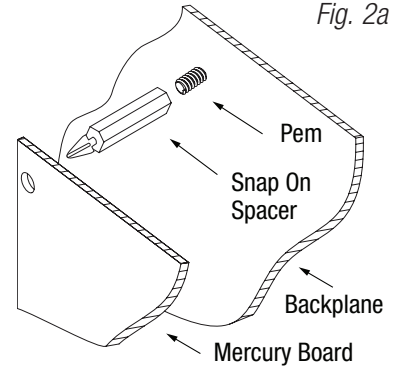

Fig. 2a



T2M35XK1(D): Configuration of Mercury Boards on TMV2 Door Backplane:

1. Position access controller module over corresponding spacers and depress onto snap on spacers (Fig. 3, pg. 4).
2. Mount backplane to enclosure with hardware.

Access Controller Position Chart for the Following Models:

LenelS2 / Mercury Access Controller	Pem Mounting
MR52	(B)

Fig. 3

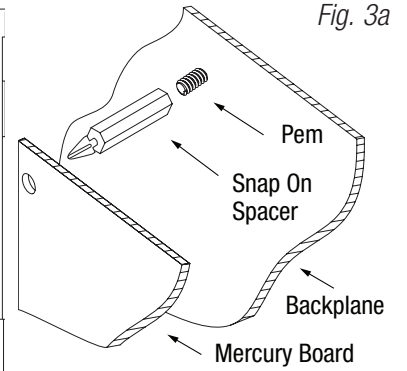
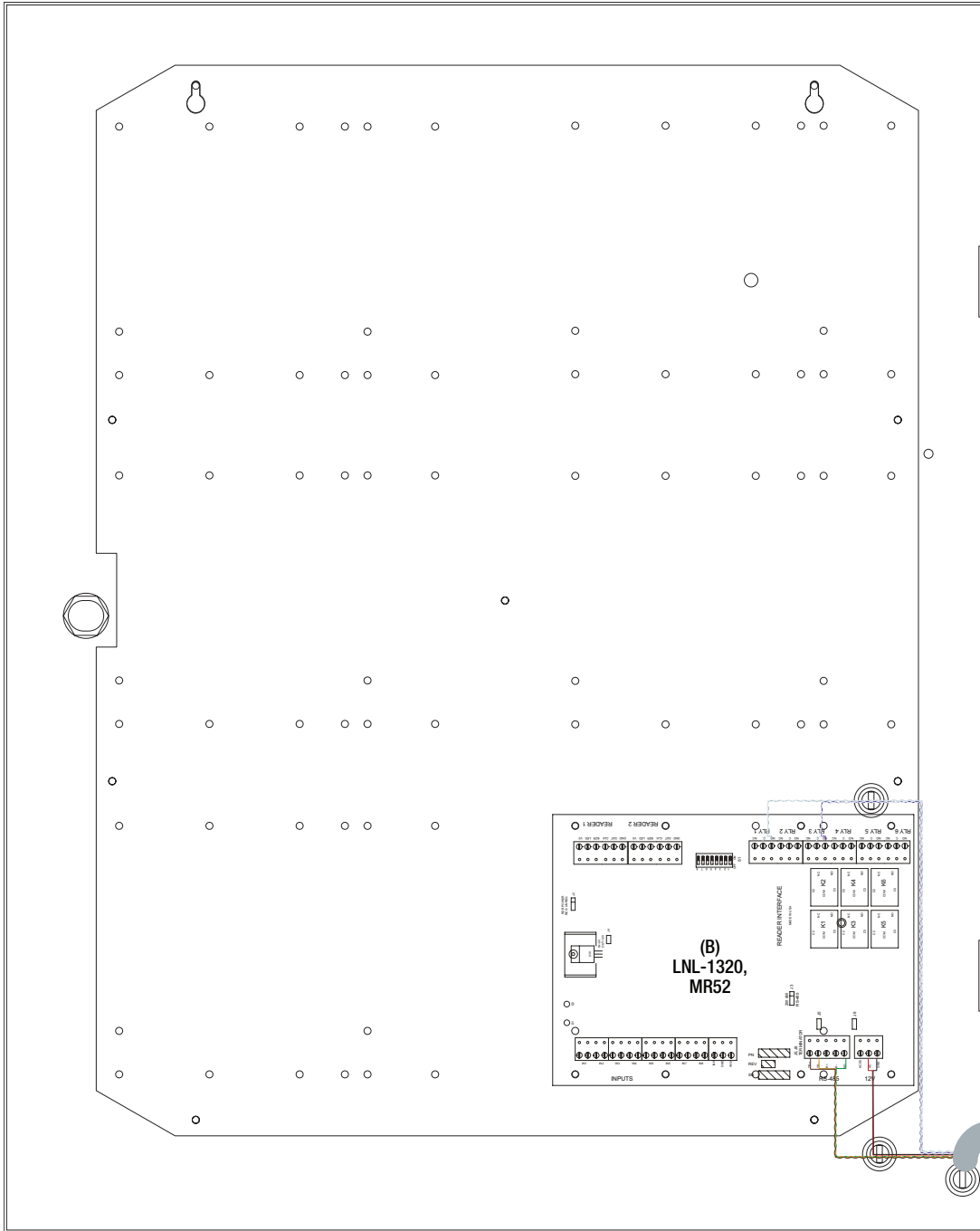
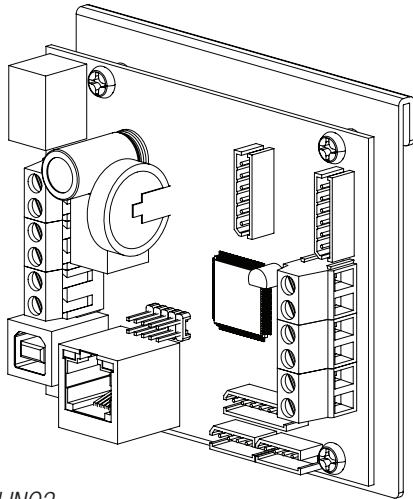

Fig. 3a



eFlow Power Supply/Chargers can be Controlled and Monitored while Reporting Power/Diagnostics from Anywhere over the Network...



LINQ™

LINQ2 - Network Communication Module

LINQ2 provides remote IP access to real-time data from eFlow power supply/chargers to help keep systems up and running at optimal levels. It facilitates fast and easy installation and set-up, minimizes system downtime, and eliminates unnecessary service calls, which helps reduce Total Cost of Ownership (TCO) - as well as creating a new source of Recurring Monthly Revenue (RMR).

LINQ2

Features:

- UL Listed in the U.S. and Canada.
- Local or remote control of up to (2) two Altronix eFlow power output(s) via LAN and/or WAN.
- Monitor real time diagnostics: DC output voltage, output current, AC & battery status/service, input trigger state change, output state change and unit temperature.
- Access control and user management: Restrict read/write, Restrict users to specific resources
- Two (2) integral network controlled Form "C" Relays.
- Three (3) programmable input triggers: Control relays and power supplies via external hardware sources.
- Email and Windows Dashboard notifications
- Event log tracks history.
- Secure Socket Layer (SSL).
- Programmable via USB or web browser - includes operating software and 6 ft. USB cable.

LINQ2 Mounts Inside any Trove Enclosure

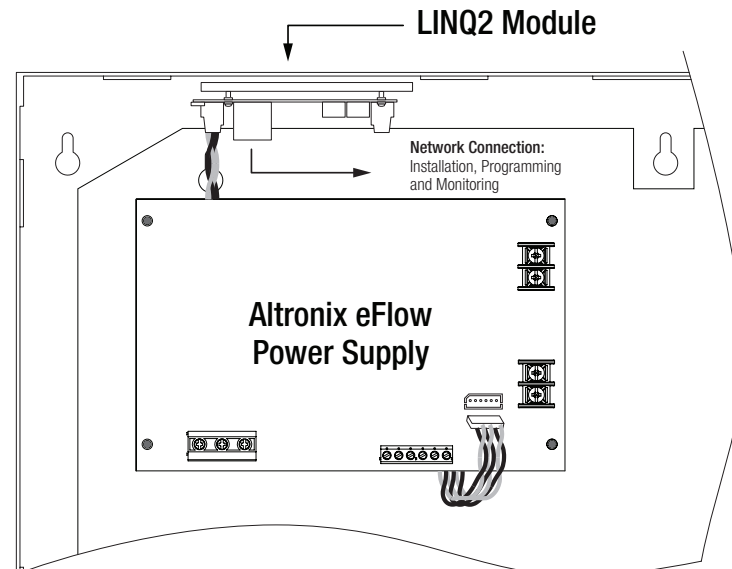

Notes:

Notes:

Trove2 Enclosure Dimensions (H x W x D approximate):

27.25" x 21.5" x 6.5" (692.2mm x 552.5mm x 165.1mm)

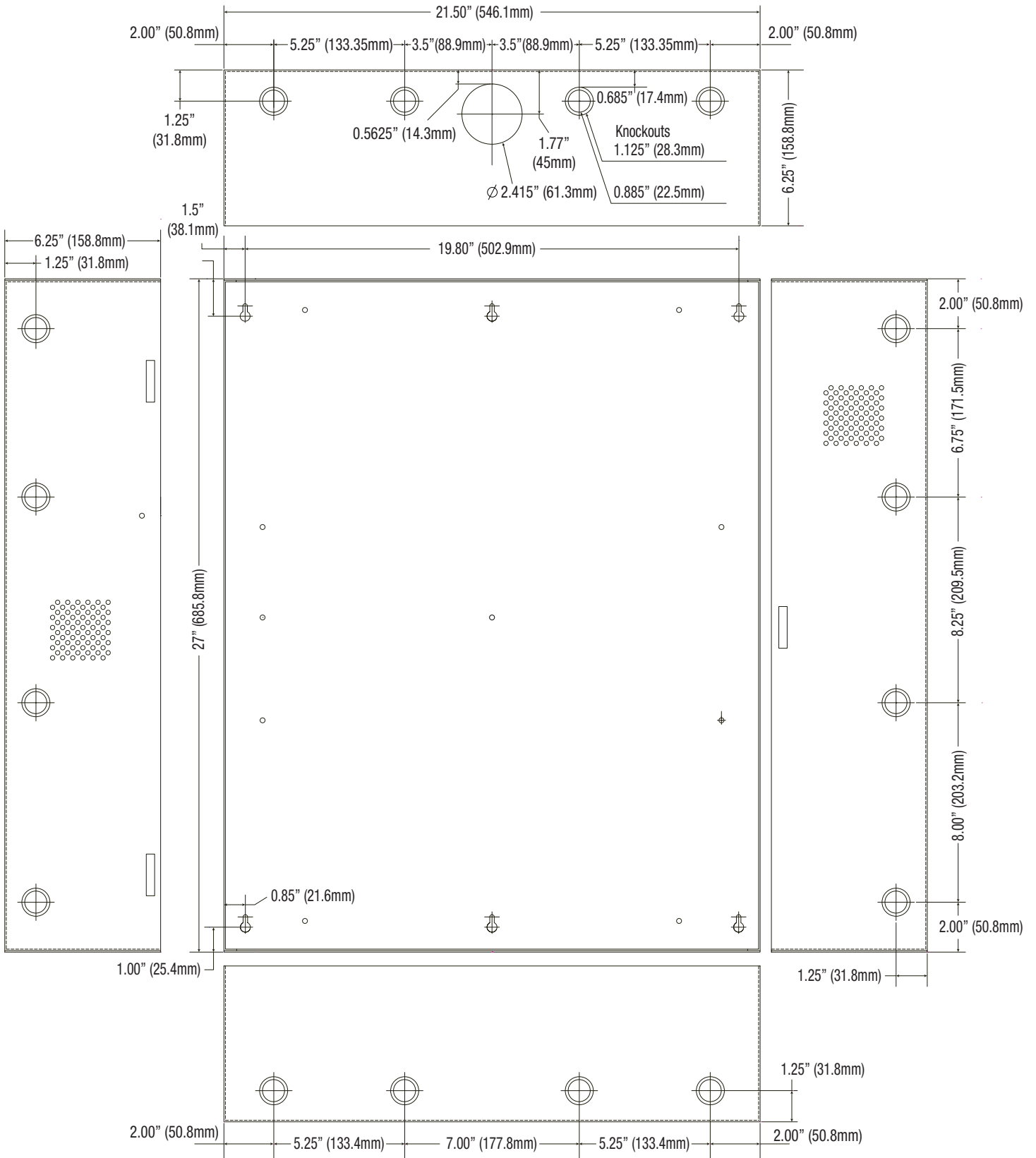

Altronix is not responsible for any typographical errors. Product specifications are subject to change without notice.

140 58th Street, Brooklyn, New York 11220 USA | phone: 718-567-8181 | fax: 718-567-9056
 website: www.altronix.com | e-mail: info@altronix.com | Lifetime Warranty
 IIT2M35XK1(D)

K18X

